

## **BEAR PAW, KIT INSTALLATION INSTRUCTIONS**

### **MODELS: BELL 505**

Equipped with Standard (Low) Landing Gear Only

Read all of the Installation Instructions  
thoroughly prior to performing any activities relating to this product



## **Table of Contents**

<u>Section</u>	<u>Description</u>	<u>Page</u>
1	Description	2
2	Installation & Removal Instructions	3
	Applicability	3
	Installation Instructions	4
	Removal Instructions	9

## **Notes**

1. If changes to this document are required, Alpine Aerotech LP shall revise all pages and reissue the entire document.
2. Alpine Aerotech LP shall make any subsequent revisions of this document available free of charge upon request. Alpine Aerotech LP also recommends that the end user of this product periodically verify the revision level of this document.

## **Section 1 Description**

The following information provides a functional description of the Bear Paw, Kit as defined in Alpine Aerotech LP authority dataset AAL-390-020-001.

- In soft terrain landing situations (i.e. tundra, snow and sand) where the skid tubes can sink into the landing area, balancing issues can occur and in rare cases the tail rotor can strike the ground.
- When installed, the Bear Paw, Kit provides additional flotation to the skid gear AFT of the aircraft's C of G, therefore increasing stability and decreasing the potential of a tail rotor strike.



**Section 2    Installation & Removal Instructions**

**Applicability**

The Bear Paw, Kit (AAL-390-020-001) is applicable to all serial numbers, equipped with standard (low) landing gear only.

**Weight & Balance**

<u>Part Number</u>	<u>Description</u>	<u>Weight</u>	<u>Long. Arm</u>	<u>Lat. Arm</u>
AAL-390-020-001	Bear Paw, Kit †	17.99* 8.16 (Kg)	184.232 4.68 (m)	.000 .00 (m)
AAL-390-020-001	Bear Paw, Kit ‡	17.02* 7.72 (Kg)	184.848 4.70 (m)	.000 .00 (m)

† Applicable to installations with Grippers (Item 11) and associated hardware

‡ Applicable to installations without Grippers (Item 11) and associated hardware

\* Total increase in weight to aircraft.

**General Notes**

- All Installation Instructions shall be accomplished in accordance with (IAW) standard aircraft practices. Refer to the current revision of the FAA Advisory Circular AC 43.13-1 and AC 43.13-2 for details on standard aircraft practices.
- Torque fasteners IAW the tension type torque limits indicated in the current revision of the FAA Advisory Circular AC 43.13-1, Table 7-1 unless otherwise specified.
- All Dimensions are in imperial measures (inches/pounds).
- Refer to the current revision of the Bear Paw, Kit Instruction for Continuing Airworthiness (AAL-390-025-701) for the part numbers of the item(s) referenced within this document.
- Refer to the current revision of the Bear Paw, Kit Instruction for Continuing Airworthiness (AAL-390-025-701) for instructions on continuing airworthiness for the item(s) referenced within this document.

**Installation Notes**

△<sub>1</sub> Typical item number for all like items in this view unless otherwise specified.

△<sub>2</sub> Apply Threadlocker (Item 15) to threads IAW manufacturer's recommendations (prior to torquing fastener).



## Installation Instructions

**NOTE:** LHS installation shown, RHS opposite.

1. Install the Grippers (Item 11) and supplied hardware on the Bear Paw, Detail (Item 1) as shown. Ensure all serrated surfaces on the Grippers are facing down (serrations must be common to the ground). Ensure Threadlocker (Item 15) is applied (mandatory). Torque all Gripper fasteners IAW General Note 2. Reference Figure 1.

**NOTE:** Installation of Grippers (Item 11) and associated hardware is optional.

If Grippers are desired, all Grippers (8X) and associated hardware must be installed. Use applicable Weight & Balance data accordingly.

If Grippers are not desired, all Grippers (8X) and associated hardware must be removed. Use applicable Weight & Balance data accordingly.

**CAUTION:** Ensure Threadlocker (Item 15) is sufficiently applied to all Gripper fasteners. Omitting threadlocker is not acceptable and will create a non-airworthy installation.

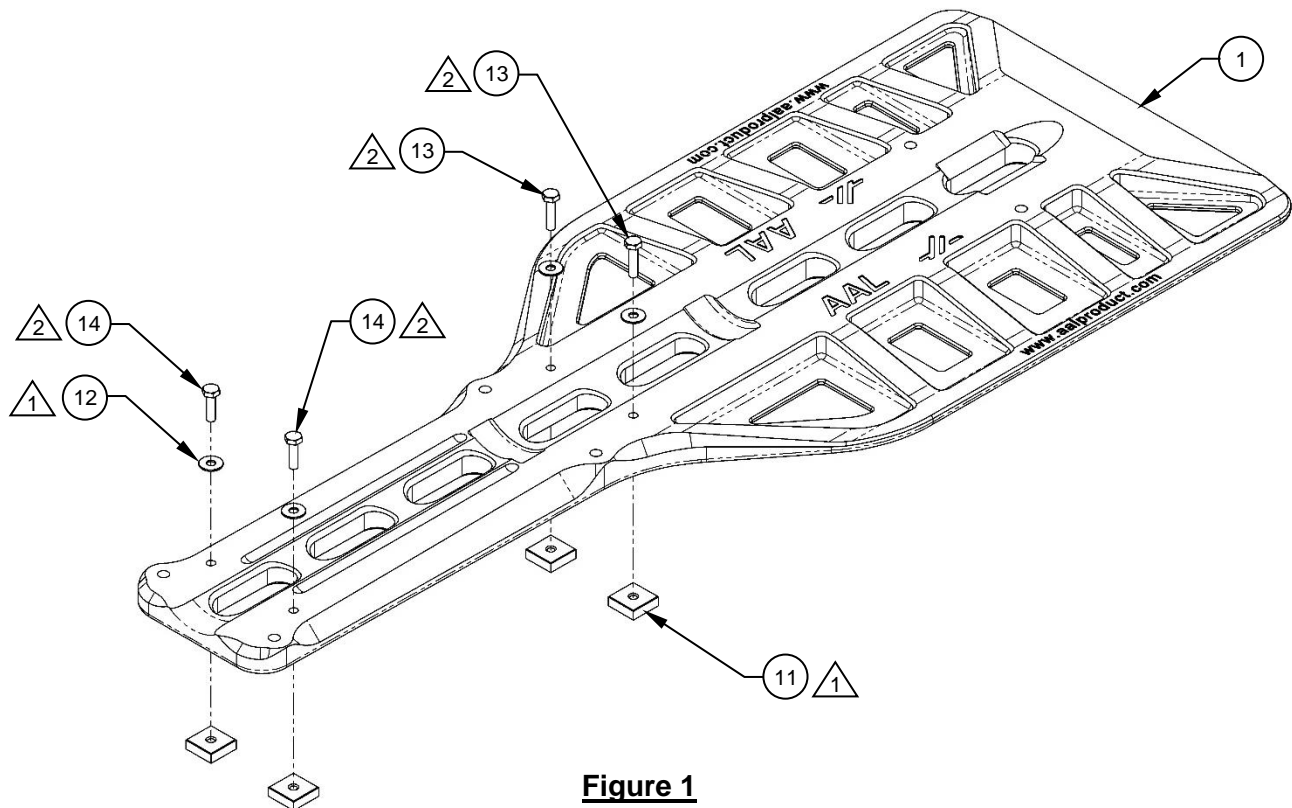
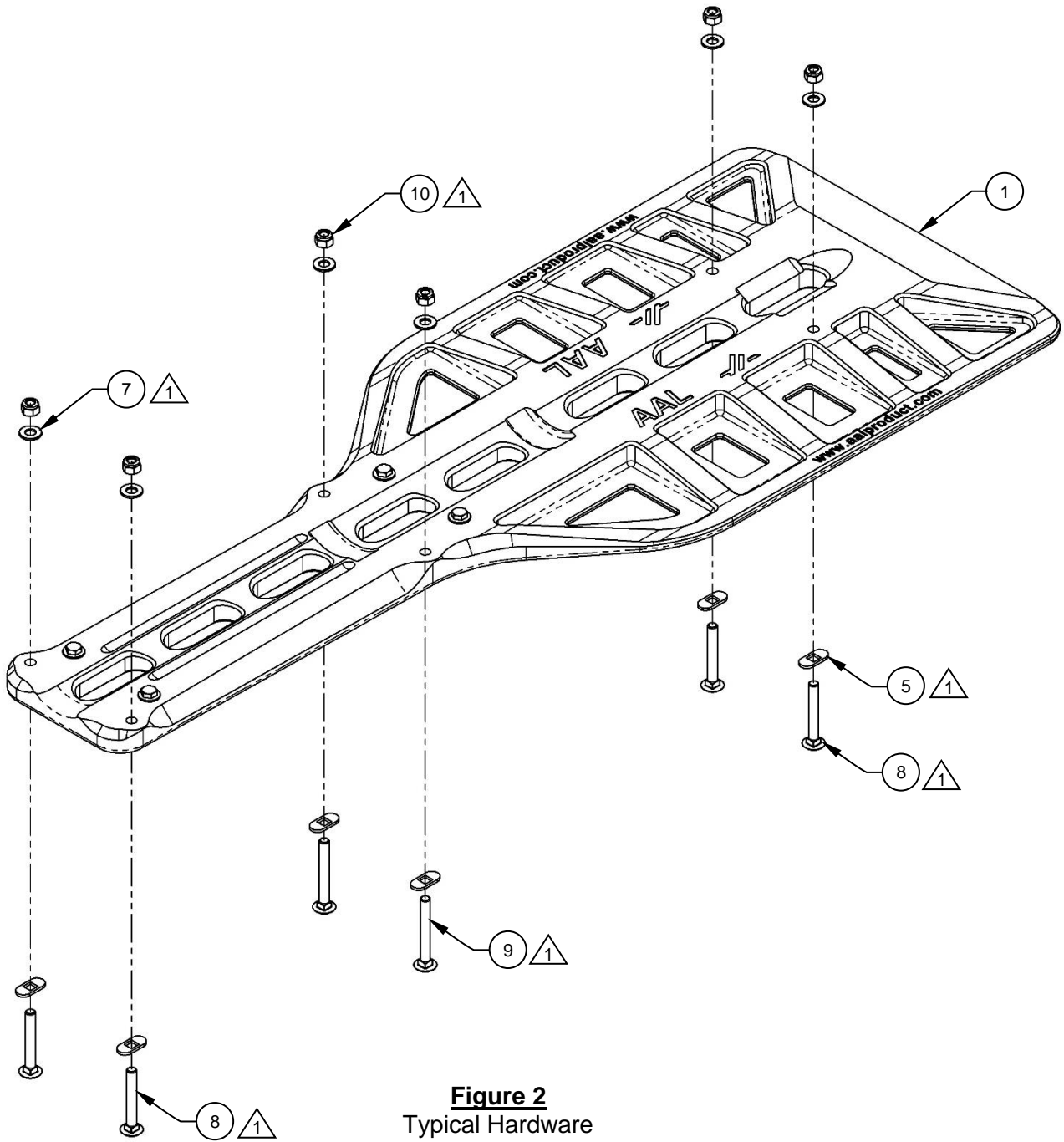

**Figure 1**  
Typical Gripper  
Installation



**Installation Instructions**

2. Install the supplied hardware on the Bear Paw, Detail (Item 1) as shown. Reference Figure 2.

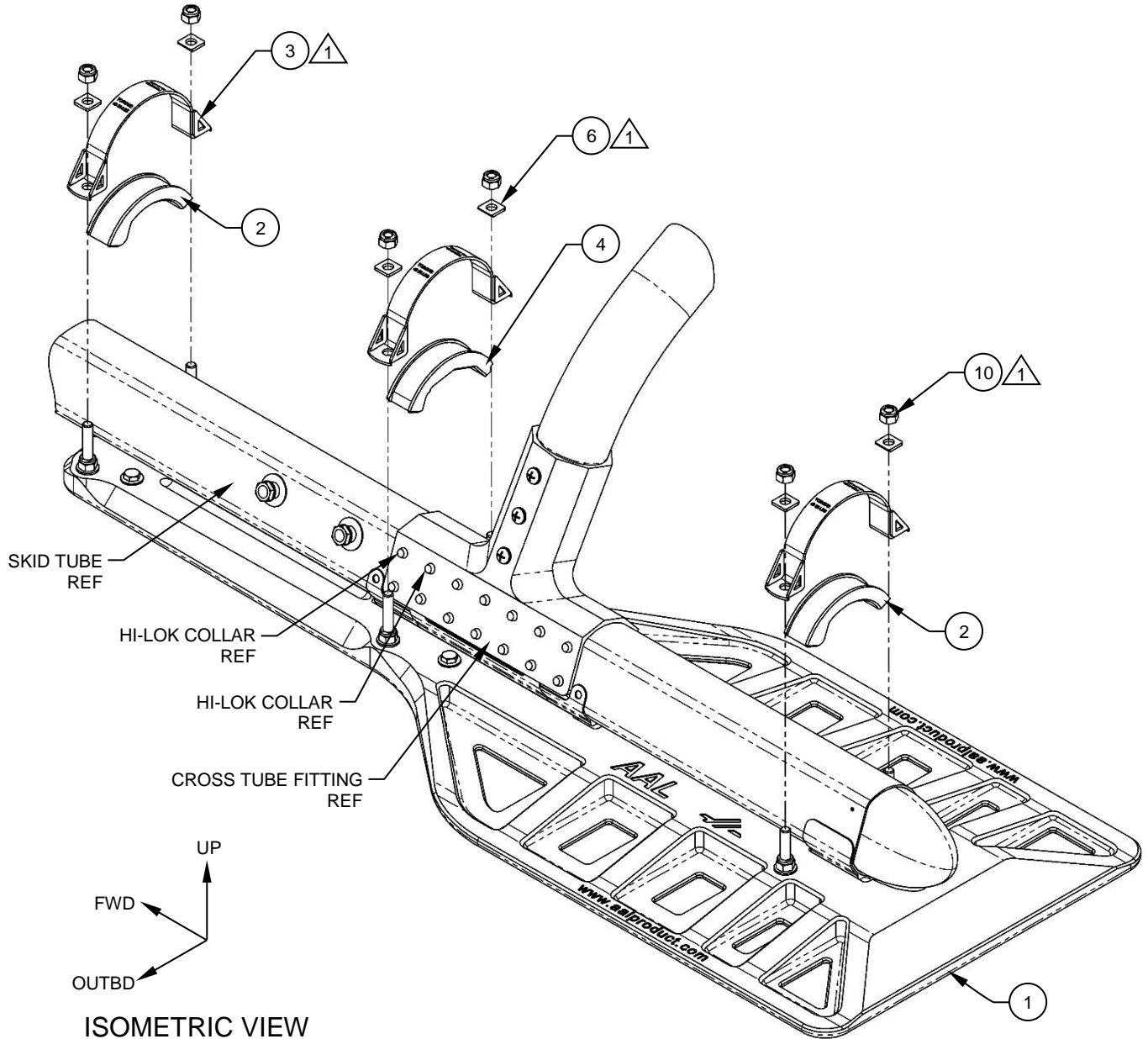

**Figure 2**  
Typical Hardware  
Installation



**Installation Instructions** (cont.)

3. Raise the aircraft so the Bear Paw, Detail (Item 1) can be slide under the skid tube. Reference Figure 3.



**ISOMETRIC VIEW  
LHS INSTALLATION  
SHOWN**

**Figure 3**  
LHS Shown  
RHS Opposite





**Installation Instructions** (cont.)

4. Once the Bear Paw, Detail (Item 1) is under the skid tube in its approximate location, place the Strap, Assys (Item 3) and their respective Cap, Details (Items 2 & 4) on their corresponding bolts. Reference Figure 2.

**NOTE:** Ensure the Cap, Detail (Item 4) is oriented between the two forward Hi-Lok Collars common to the cross tube fitting.

**NOTE:** Ensure the Cap, Details (Item 2 & 4) are oriented properly on top of the skid tube and cross tube fitting.

5. Install the supplied Washer (Item 6) and Nut (Item 10) on each bolt. Reference Figure 2.

**NOTE:** Ensure the radius edge of the Washer (Item 6) is oriented down and towards the skid tube. Reference Figure 3.

**NOTE:** A “thin-wall” socket may be required to adequately engage the Nut (Item 10).

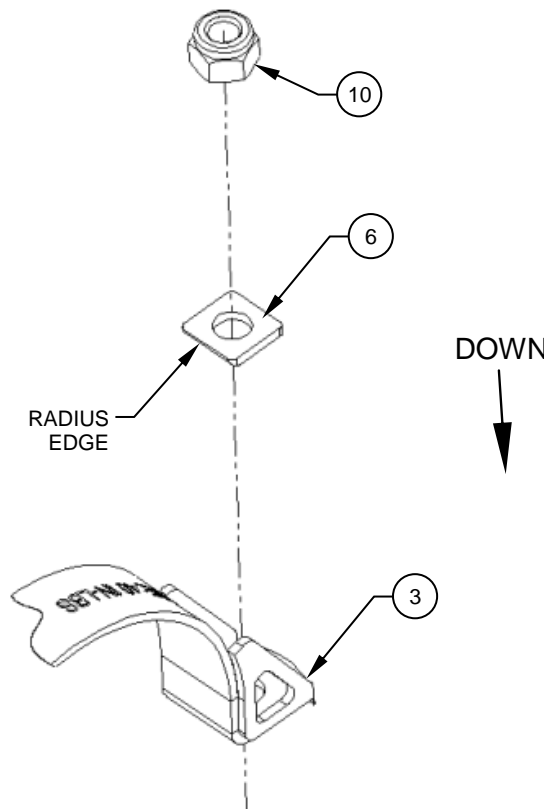

**Figure 4**



**CAUTION:** Do **NOT** apply full torque to the fasteners at this stage while the aircraft is raised off the ground. Only apply minimal torque to snug-up the Bear Paw, Detail (Item 1).

6. Lower the aircraft onto the Bear Paw, Detail (Item 1) and torque the fasteners equally to 40 in/lbs. Reference Figure 2.

**CAUTION:** Before applying torque, ensure the Cap, Detail (Item 4) is oriented between the two forward Hi-Lok Collars common to the cross tube fitting. Reference Step 3.

7. Installation complete.
8. Perform a General Inspection of all items to ensure proper installation.
9. Update the aircraft logbook for the installation of the Bear Paw, Kit.





### **Removal Instructions**

1. As there are no special considerations or additional steps to remove the Bear Paw, Kit for either inspections, or mission configuration, the removal of the Bear Paw, Kit can be considered the opposite of installation.
2. Perform a General Inspection of all items to ensure proper removal.
3. Update the aircraft logbook for the removal of the Bear Paw, Kit.