

## **DEEP SNOW, KIT INSTALLATION INSTRUCTIONS**

### **MODELS: BELL 429**

Read all of the Instructions for Continuing Airworthiness thoroughly prior to performing any activities relating to this product

## **Table of Contents**

<b><u>Section</u></b>	<b><u>Description</u></b>	<b><u>Page</u></b>
1	Description	2
2	Installation & Removal Instructions	3
	Applicability	3
	Installation Instructions	4
	Hoist Configuration Installation Instructions	7
	Removal Instructions	11

## **Notes**

1. If changes to this document are required, Alpine Aerotech LP shall revise all pages and reissue the entire document.
2. Alpine Aerotech LP shall make any subsequent revisions of this document available free of charge upon request. Alpine Aerotech LP also recommends that the end user of this product periodically verify the revision level of this document.

## **Section 1    **Description****

The following information provides a functional description of the Deep Snow, Kit as defined in Alpine Aerotech LP authority dataset AAL-490-010-901.

- In soft terrain landing situations (i.e. tundra, snow and sand) where the skid tubes can sink into the landing area, The Deep Snow, Kit provides increased floatation and damage tolerance.
- When installed, the Deep Snow, Kit provides additional flotation to the skid gear in the center of the aircraft's C of G, therefore increasing stability and flotation.

---

## **Section 2 Installation & Removal Instructions**

### **Applicability**

The Deep Snow, Kit (AAL-490-010-901) is applicable to all serial numbers, equipped with standard (low) landing gear only.

### **Weight & Balance**

<u>Part Number</u>	<u>Description</u>	<u>References</u>
AAL-490-010-901	Deep Snow, Kit	AAL-490-015-701 Section 3 AAL-490-025-701 Section 3 AAL-490-035-701 Section 3

### **General Notes**

1. Please install the AAL Deep Snow, Kit (AAL-490-010-901) in the following order; Bear Paw Assy, Kit (AAL-490-010-001), then the Traction Paw, Assy (AAL-490-020-001), lastly the Yeti Paw, Assy (AAL-490-030-001).
2. All Installation Instructions shall be accomplished in accordance with (IAW) standard aircraft practices. Refer to the current revision of the FAA Advisory Circular AC 43.13-1 and AC 43.13-2 for details on standard aircraft practices.
3. Torque fasteners IAW the tension type torque limits indicated in the current revision of the FAA Advisory Circular AC 43.13-1, Table 7-1 unless otherwise specified.
4. All Dimensions are in imperial measures (inches/pounds).
5. Refer to Section 2: Maintenance Manual Supplement for instructions on maintenance for the item(s) referenced within this section.
6. Refer to Section 4: Illustrated Parts Breakdown for the part numbers of the item(s) referenced within this section.

### **Installation Notes**

 Typical item number for all like items in this view unless otherwise specified.

### **Installation Instructions**

**NOTE:** LHS installation shown, RHS opposite.

1. Install the Bear Paw Assy, Kit (Item 1) first as per AAL-490-015-701 Section 3. Reference Figure 1.

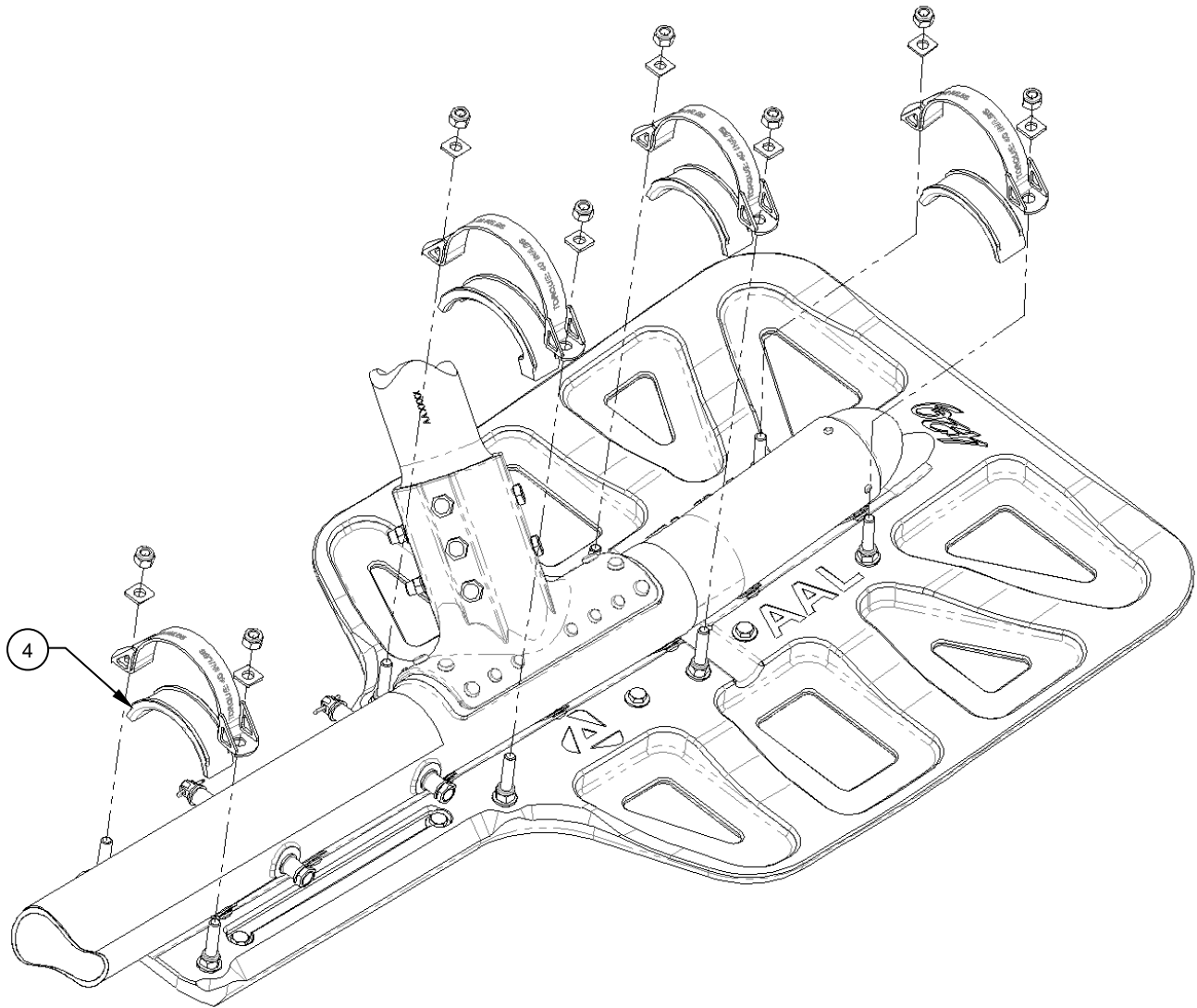

**Figure 1**  
Modified  
Installation of Item 1

**Installation Instructions**

2. One variation of the standard install is to be made. Reference page 11 of 20 in AAL-490-015-701 Section 3, remove the Cap, Detail (Item 2) and replace it with Cap, Detail (Item 4). Reference Figure 1.
3. Install the Traction Paw, Assy normally as per AAL-490-025-701 Section 3. Reference Figure 2.

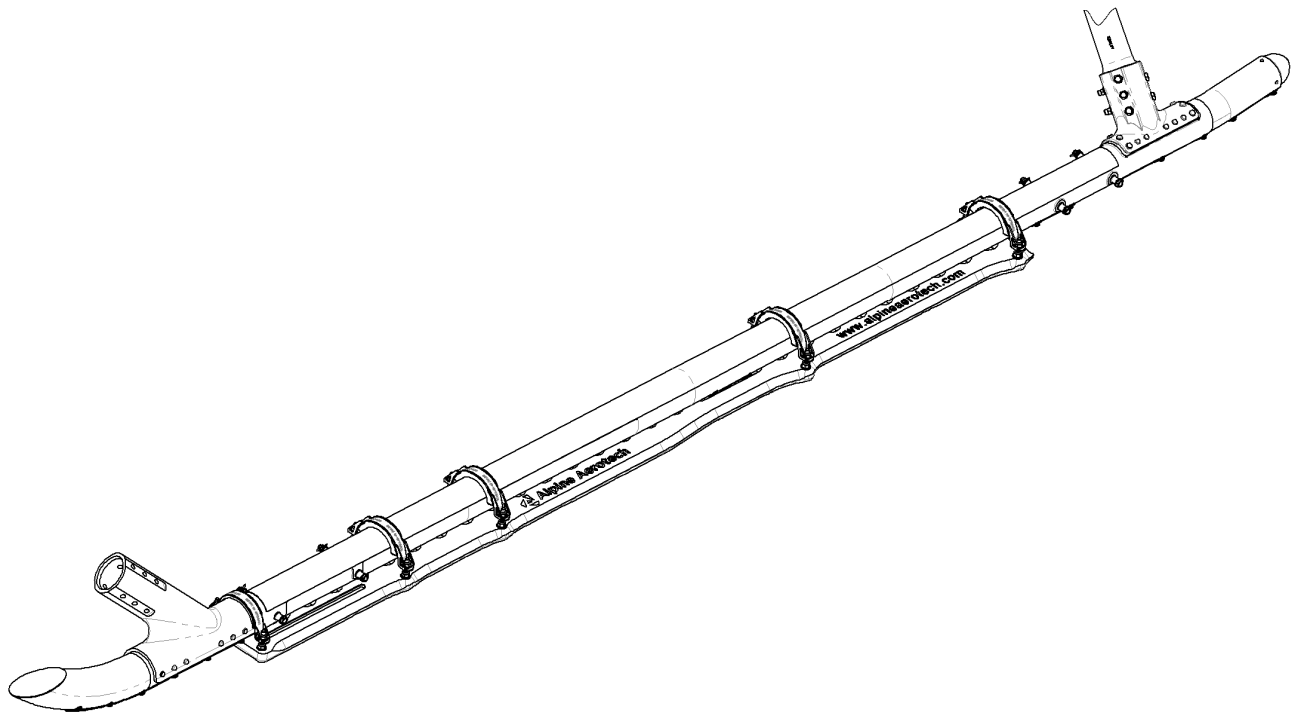

**Figure 2**  
Traction Paw, Assy  
Shown

### **Installation Instructions**

4. Install the Yeti Paw, Assy normally as per AAL-490-035-701 Section 3. Reference Figure 3.

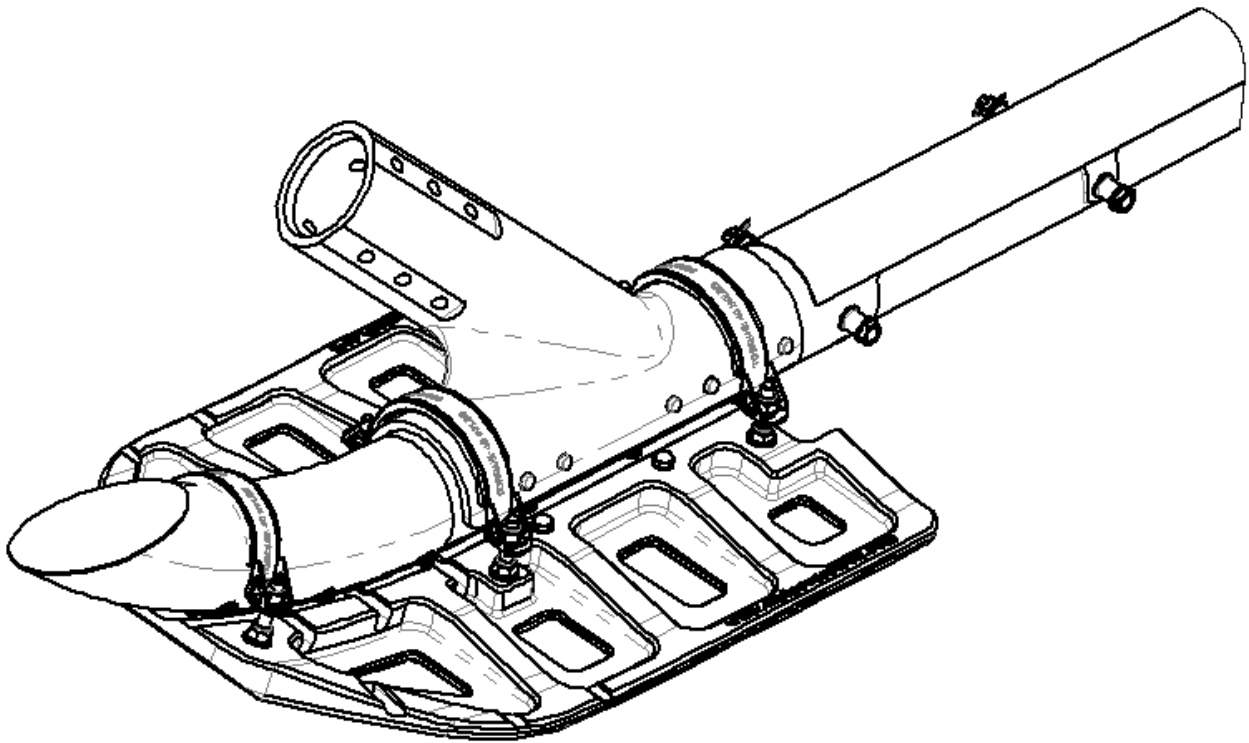
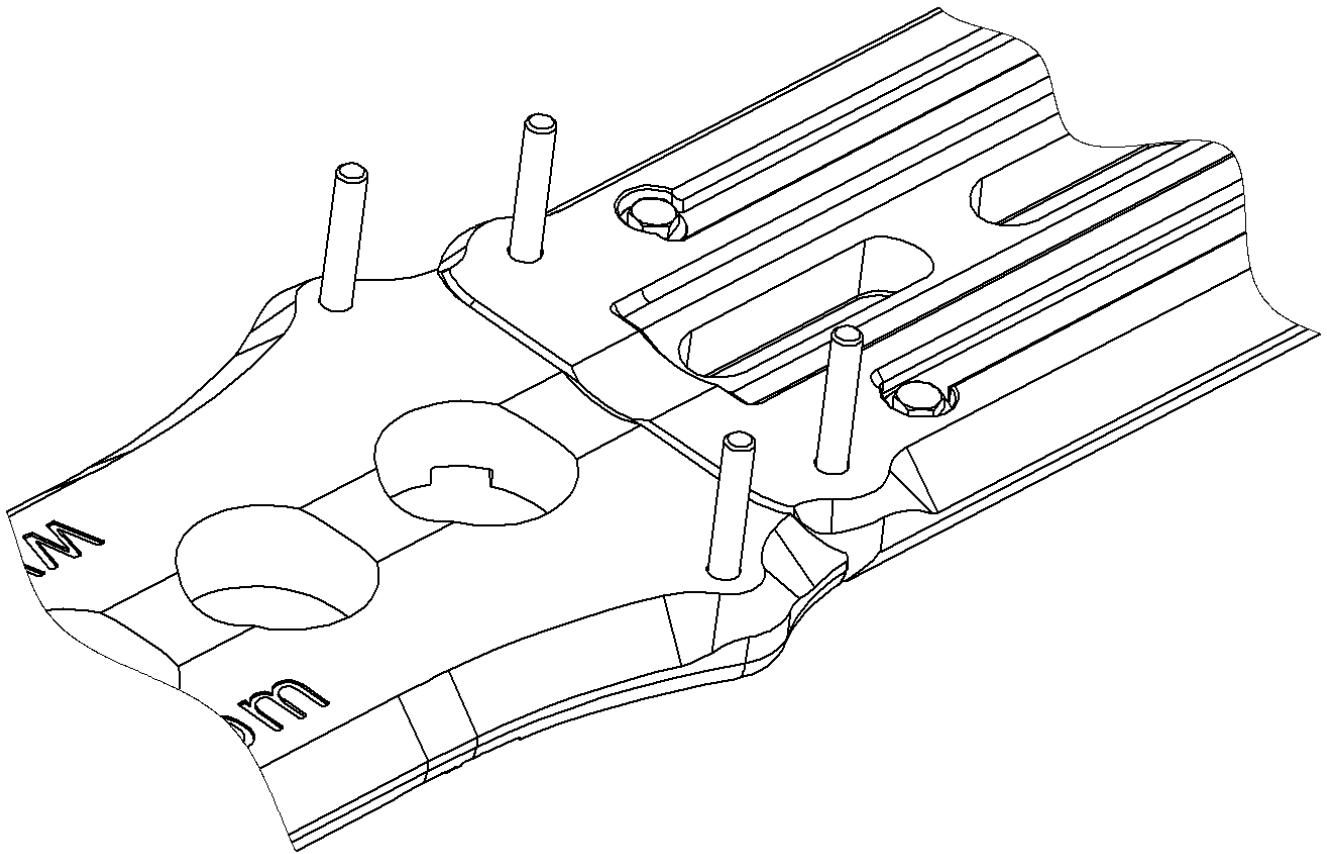

**Figure 3**  
Yeti Paw, Assy  
Shown

5. Installation complete.
6. Perform a General Inspection of all items to ensure proper installation.
7. Update the aircraft logbook for the installation of the Traction Paw, Kit.

### **Installation Instructions – Hoist Configuration**

1. For aircraft configured for hoisting operations, temporarily remove the RHS AFT INBD and OUTBD nut and washer retaining the carriage bolts on the Traction Paw, Assy, (Item 2). See Figure 4.
2. Temporarily remove the RHS FWD INBD and OUTBD nut and washer, retaining the carriage bolts on the Bear Paw, Assy, Kit, (Item 1). See Figure 4.



**Figure 4**  
RHS Removal of Retention Nut  
and Washer Shown

**Installation Instructions – Hoist Configuration**

3. On the OUTBD side install 1x Splice, Detail (Item 5), on the two OUTBD carriage bolts, and 1x Connector, Detail, (Item 6), on the AFT end of the Traction Paw, Assy & FWD end of the Bear Paw, Assy, Kit, (Item 1). See Figure 5.
4. On the INBD side install 1x Connector, Detail, (Item 6), on the AFT end of the Traction Paw, Assy & FWD end of the Bear Paw, Assy, Kit, (Item 1). See Figure 5.
5. Re-install the appropriate washers and nuts and apply the appropriate torque IAW the tension type torque limits indicated in the current revision of the FAA Advisory Circular AC 43.13-1, Table 7-1.
6. This will lock the Traction Paw, Assy, (Item 2), & the Bear Paw, Assy, Kit, (Item 1) together and will require them to be positioned under the skid tube as a unit.
7. Continue installation IAW AAL-490-025-001 & AAL-490-015-001.

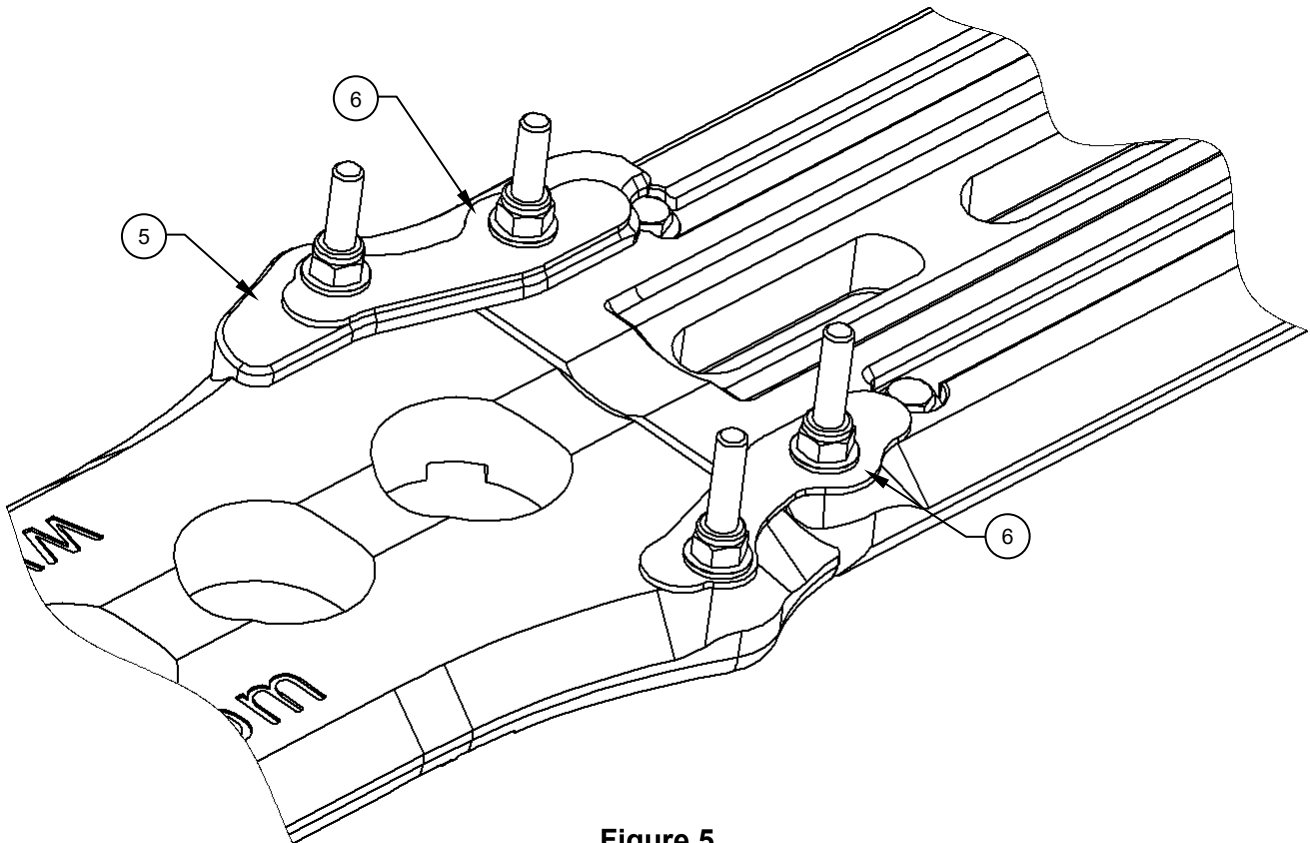
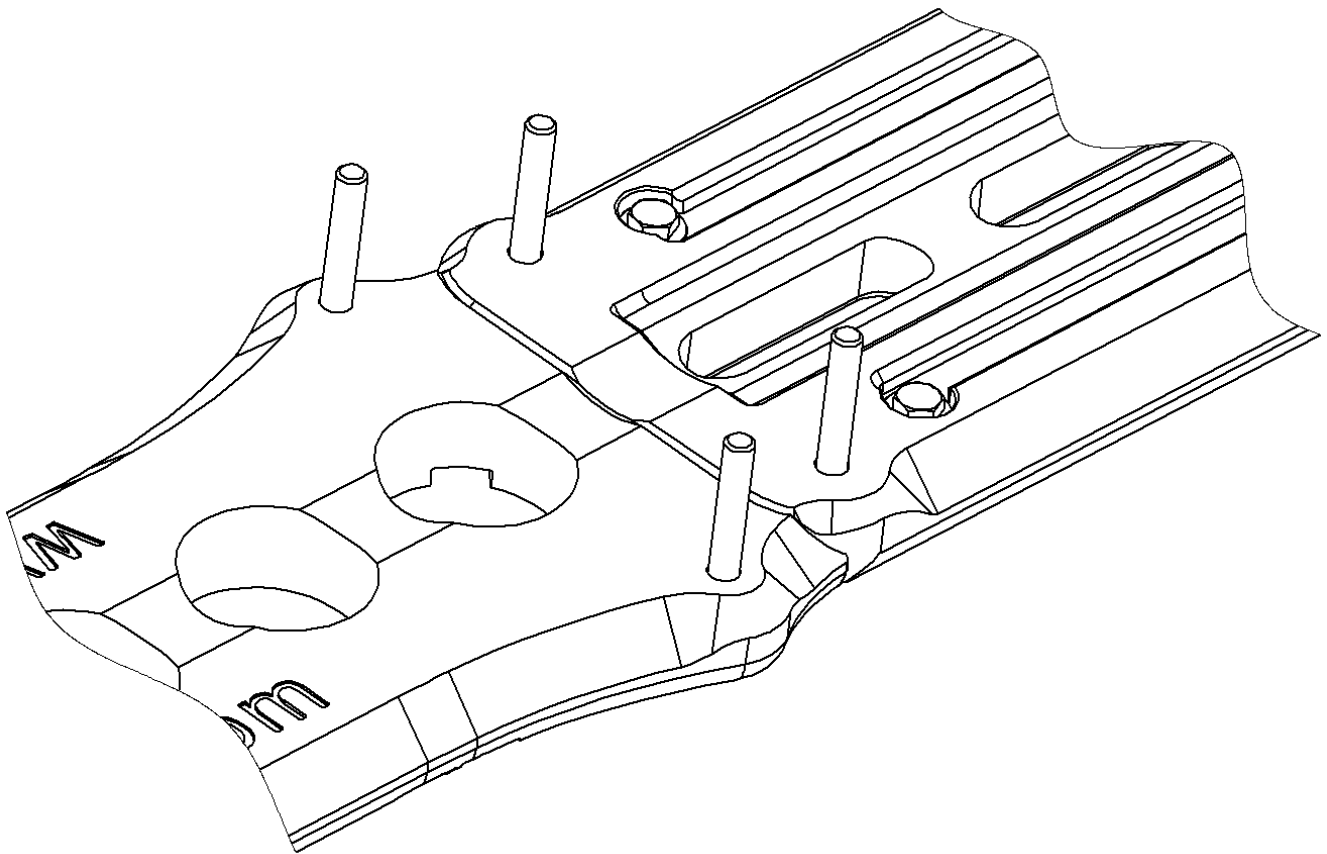

**Figure 5**  
RHS Installation of Hoist Configuration  
Components Shown

**Installation Instructions – Hoist Configuration**



8. For aircraft configured for hoisting operations, temporarily remove the HS AFT INBD and OUTBD nut and washer retaining the carriage bolts on the Traction Paw, Assy, (Item 2). See Figure 6.
9. Temporarily remove the LHS FWD INBD and OUTBD nut and washer, retaining the carriage bolts on the Bear Paw, Assy, Kit, (Item 1). See Figure 6.



**Figure 6**  
LHS Removal of Retention Nut  
and Washer Shown

### **Installation Instructions – Hoist Configuration**

10. On the OUTBD side install 1x Connector, Detail, (Item 6), on the AFT end of the Traction Paw, Assy & FWD end of the Bear Paw, Assy, Kit, (Item 1). See Figure 7.
11. On the INBD side install 1x Connector, Detail, (Item 6), on the AFT end of the Traction Paw Assy & FWD end of the Bear Paw, Assy, Kit, (Item 1). See Figure 7.
12. Re-install the appropriate washers and nuts and apply the appropriate torque IAW the tension type torque limits indicated in the current revision of the FAA Advisory Circular AC 43.13-1, Table 7-1.
13. This will lock the Traction Paw, Assy, (Item 2), & the Bear Paw, Assy, Kit, (Item 1) together and will require them to be positioned under the skid tube as a unit.
14. Continue installation IAW AAL-490-025-001 & AAL-490-015-001.

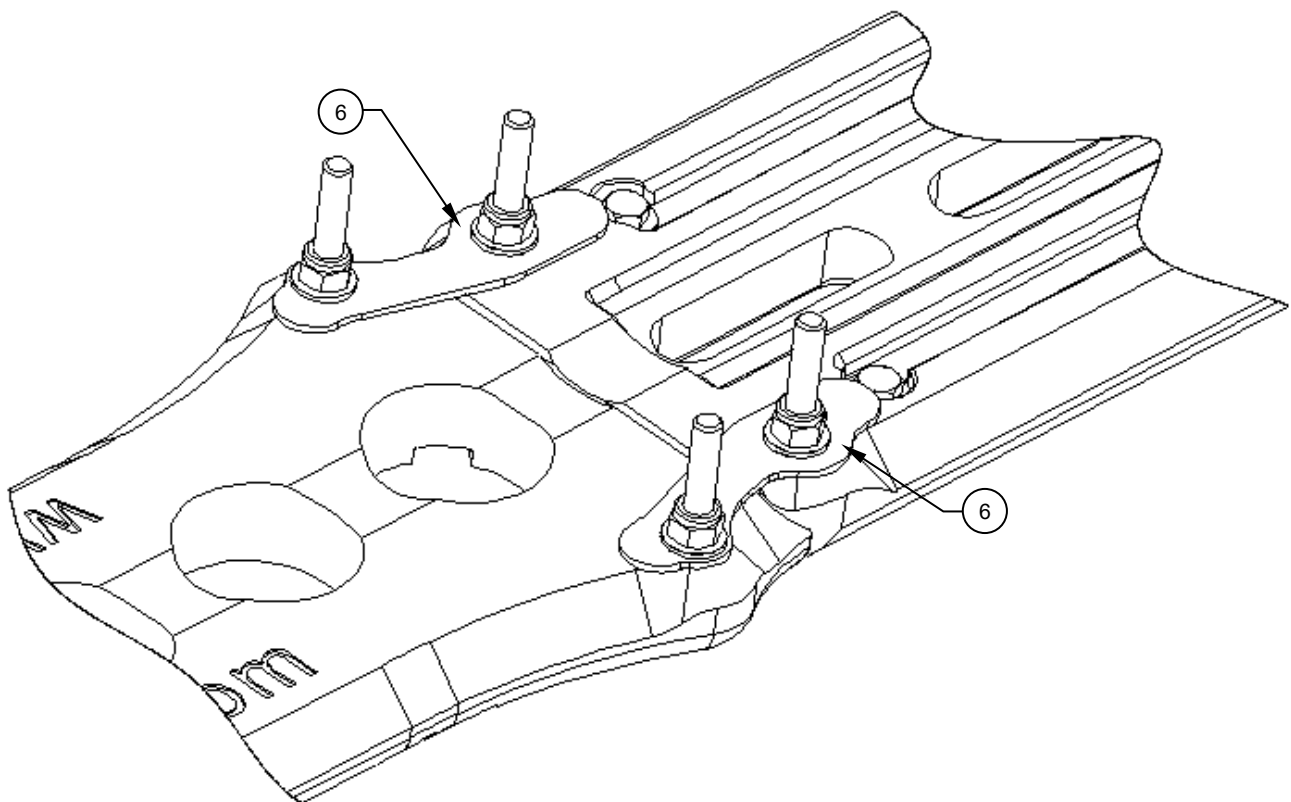

**Figure 7**  
LHS Installation of Hoist Configuration  
Components Shown

**Removal Instructions**

1. As there are no special considerations or additional steps to remove the Deep Snow, Kit for either inspections, or mission configuration, the removal of the Deep Snow, Kit can be considered the opposite of installation.
2. Perform a General Inspection of all items to ensure proper removal.
3. Update the aircraft logbook for the removal of the Deep Snow, Kit.