

FLOOR PROTECTION, KIT, AFT INSTRUCTIONS FOR CONTINUING AIRWORTHINESS

MODELS: BELL 429

Read all of the Instructions for Continuing Airworthiness thoroughly prior to performing any activities relating to this product

Table of Contents

<u>Section</u>	<u>Description</u>	<u>Page</u>
1	Introduction	2
	Applicability	2
2	Description	3
3	Operation	3
4	Maintenance Instructions	4
5	Troubleshooting	6
6	Removal/Replacement	7
	6.1 Removal Instructions Floor Protection, Kit, AFT	8
	6.2 Replacement Instructions Floor Protection, Kit, AFT	13
	6.3 Removal Instructions Floor Protection, Kit, AFT, with OEM auxiliary fuel tank kit	14
	6.4 Replacement Instructions Floor Protection, Kit, AFT, with OEM auxiliary fuel tank kit	20
7	General	20
8	Airworthiness Limitations	21
9	Illustrated Parts Breakdown	22

Notes

1. If changes to this document are required, Alpine Aerotech LP shall revise all pages and reissue the entire document.
2. Alpine Aerotech LP shall make any subsequent revisions of this document available free of charge upon request. Alpine Aerotech LP also recommends that the end user of this product periodically verify the revision level of this document.

SECTION 1: INTRODUCTION

This document comprises Instructions for Continuing Airworthiness that apply to the Floor Protection, Kit, AFT, installed on Bell 429 rotorcraft. The information and data contained in this document are supplemental to the information contained in the existing ICA for the Bell 429

Applicability

The Floor Protection, Kit, AFT, (AAL-412-020-002) is applicable to Bell 429 all serial numbers with an OEM interior, and **without** the STA 249.429 Mid Canted BLKHD.

SECTION 2: DESCRIPTION

The following information provides a functional description of the Floor Protection, Kit as defined in Alpine Aerotech LP datasets AAL-412-020-002.

- The Floor Protection, Kit includes rigid pieces of material that are installed atop the existing floor to protect it from dents and punctures associated with typical aircraft usage. This occurs most frequently during loading and unloading operations, but can also occur during small inflight shifts of said cargo.
- The Floor Protection, Kit when installed, adds additional protection to the floor panels, as it is manufactured from a material specifically designed to spread and attenuate energy.

SECTION 3: OPERATION

1. With the Floor Protection, Kit, AFT installed no special considerations required for operation.

SECTION 4: MAINTENANCE INSTRUCTIONS

General Notes

1. The following information defines the instructions for continuing airworthiness, repair allowances and airworthiness limitations for the item(s) referenced within this document.
2. Refer to the current revisions of the Bell 429 Maintenance Manual for Instructions for Maintenance/Inspection with respect to the item(s) referenced within this document.
3. Refer to the Section 6: Removal & Replacement Instructions and Section 9: Illustrated Parts Breakdown for the replacement and/or installation of the item(s) referenced within this section.
4. Scheduled inspection for the item(s) referenced within this document shall be accomplished in accordance with (IAW) the Inspection Procedures specified.
5. Repair allowances for the item(s) referenced within this document shall be accomplished IAW the Repair Procedures specified.
6. Limitations for the item(s) referenced within this document are IAW the Airworthiness Limitations specified.

Inspection Procedures

Supplement to applicable Maintenance Manual, Chapter 5, Inspection and Component Overhaul Schedule

Notes

1. Refer to the applicable Maintenance Manual, Chapter 4-1 and 4-2, for general information on inspections, inspection definitions, inspection intervals, inspection methods and inspection schedules.
2. General Inspections, as indicated within this document, are defined as visual, non-thorough checks.
3. Detailed Inspections, as indicated within this document, are defined as visual and thorough, searching checks.
4. Perform 600 Hour/12 Month Inspections every 600 hours or every 12 months, whichever occurs first, prior to flight operation. If damage is detected, refer to the Repair Procedures section within this document.

Scheduled Inspections

1. 600 Hour/12 Month Inspections





Data Reference: Section 6: Removal and Installation Instructions
Section 9: Illustrated Parts Breakdown
 - I. Perform a Detailed Inspection on all items to ensure proper security.
 - II. Perform a Detailed Inspection on all items/materials to ensure proper integrity.
 - III. Perform a Detailed Inspection on the Floor Protection, Kit to ensure that it is not delaminating.
 - IV. Perform a Detailed Inspection on all surfaces & locations with Velcro applied to ensure no damage has occurred to the aircraft floor.

SECTION 5: TROUBLESHOOTING

1. Repairs to all other item(s) referenced within this document are **not** permitted. Contact Alpine Aerotech LP for further information if repairs are required to all other item(s) referenced within this document.

SECTION 6: REMOVAL/REPLACEMENT

General Notes

1. All Installation Instructions shall be accomplished IAW standard aircraft practices. Refer to the current revision of the FAA publications AC 43.13-1B and AC 43.13-2B for details on standard aircraft practices.
 2. All Dimensions are in imperial measures (inches/pounds).
 3. Refer to Section 4: Maintenance Manual Supplement for instructions on maintenance for the item(s) referenced within this section.
 4. Refer to the Section 9: Illustrated Parts Breakdown for the part numbers of the item(s) referenced within this section.
-  Remove and retain for future use.
-  Reinstall existing OEM fastener.
-  Triangular tie down strap location
-  OEM auxiliary tank and attachment assemblies; rear attachment assemblies are integral to fuel tank. Fuel tank not shown for clarity

6.1 REMOVAL INSTRUCTIONS

Floor Protection, Kit, AFT

1. Gain access to the AFT section of the cabin floor, and make ready for maintenance. Reference Figure 1.
2. Remove the AFT two screws from the two FWD most triangular tie-down rings in the cargo area (see flag note 1 in Figure 2) and remove the Retainer, Assemblies (Item 3), re-install the OEM fasteners into the OEM bracket. Reference Figure 1 and 2.

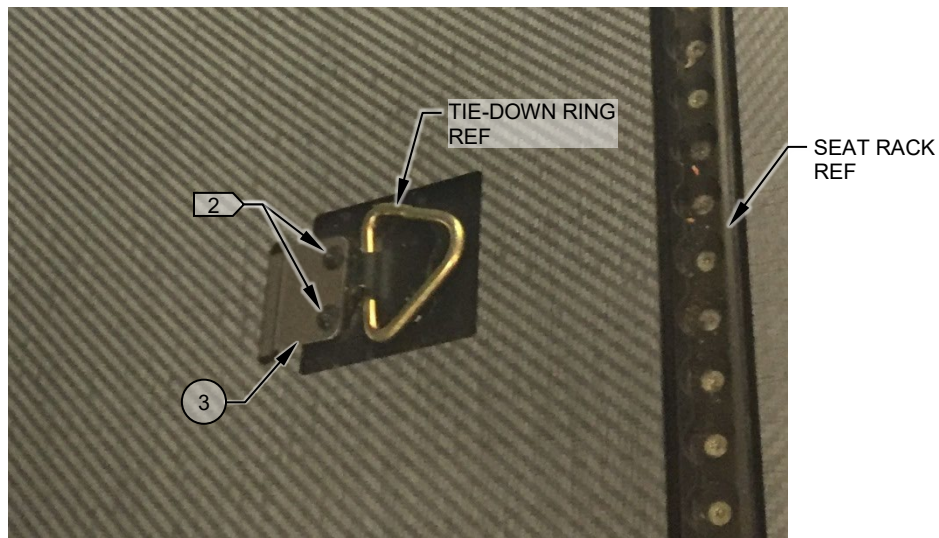
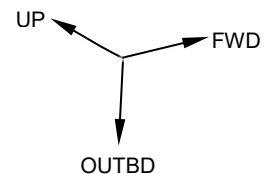

Figure 1
Removal Shown



VIEW ORIENTATION

INSTALLATION SHOWN

Removal Instructions (cont.)

Floor Protection, Kit, AFT

3. Remove the Blanking Plate, Assy (Item 6). Reference Figure 2.

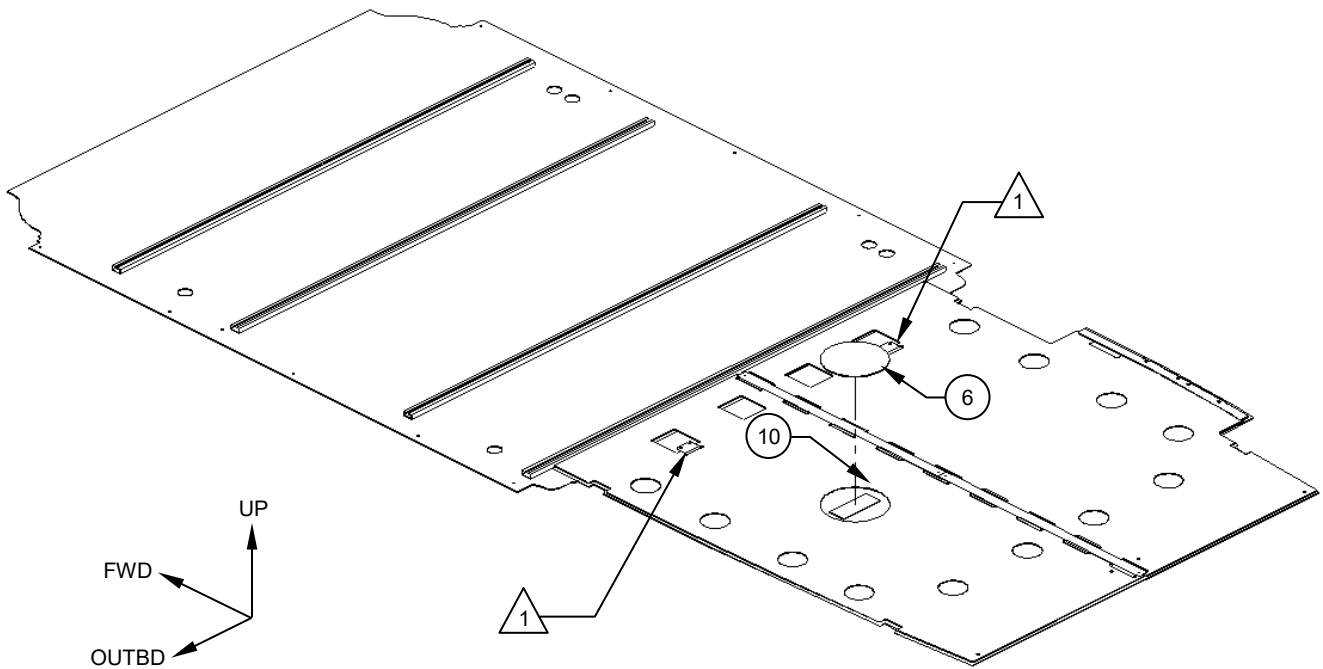

VIEW ORIENTATION

INSTALLATION SHOWN

Figure 2
Some aircraft structure
Removed for clarity

Removal Instructions (cont.)

Floor Protection, Kit, AFT

4. Remove Sill, Detail (Item 5), then re-install the OEM hardware. Remove the RHS Panel, Assy (Item 2) by tipping the panel on an angle and pulling it free from the Retainer Strip, Assy (Item 4). Reference Figures 3, 4 & 5.

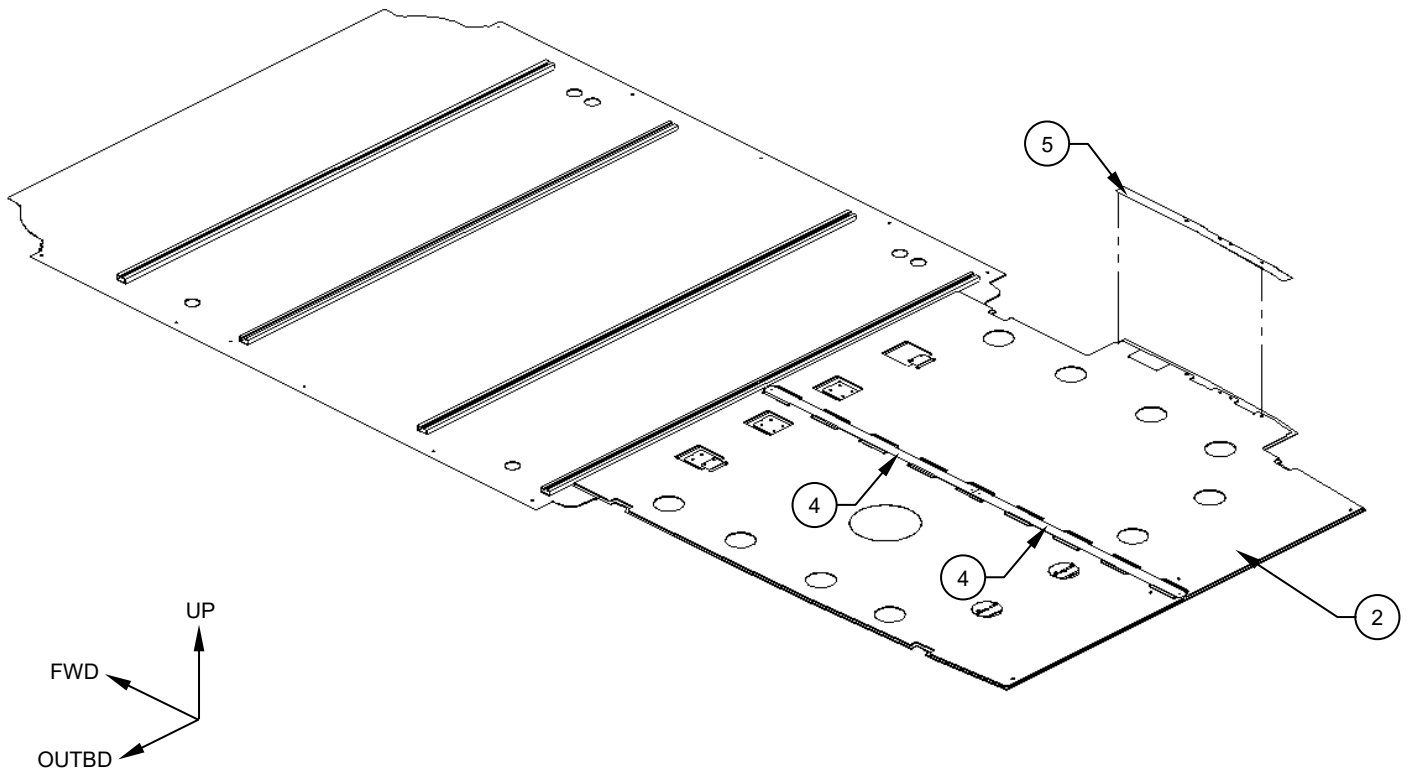

VIEW ORIENTATION

INSTALLATION SHOWN

Figure 3
Some aircraft structure
Removed for clarity

Removal Instructions (cont.)

Floor Protection, Kit, AFT

- Remove the Retainer Strip, Assy's (Item) by pulling the tabs out of the provided slots in the panel as shown. Reference Figures 3 & 4.

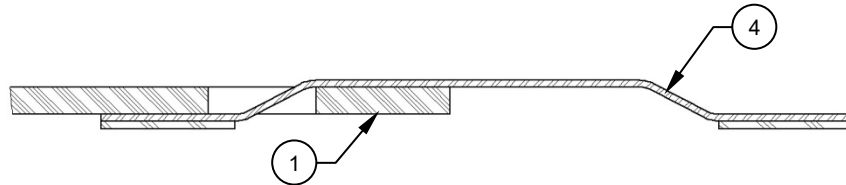

Figure 4
VIEW: A
Some aircraft structure
Removed for clarity

- Remove the LHS Panel Assy (Item 1) from the floor. Reference Figure 5.

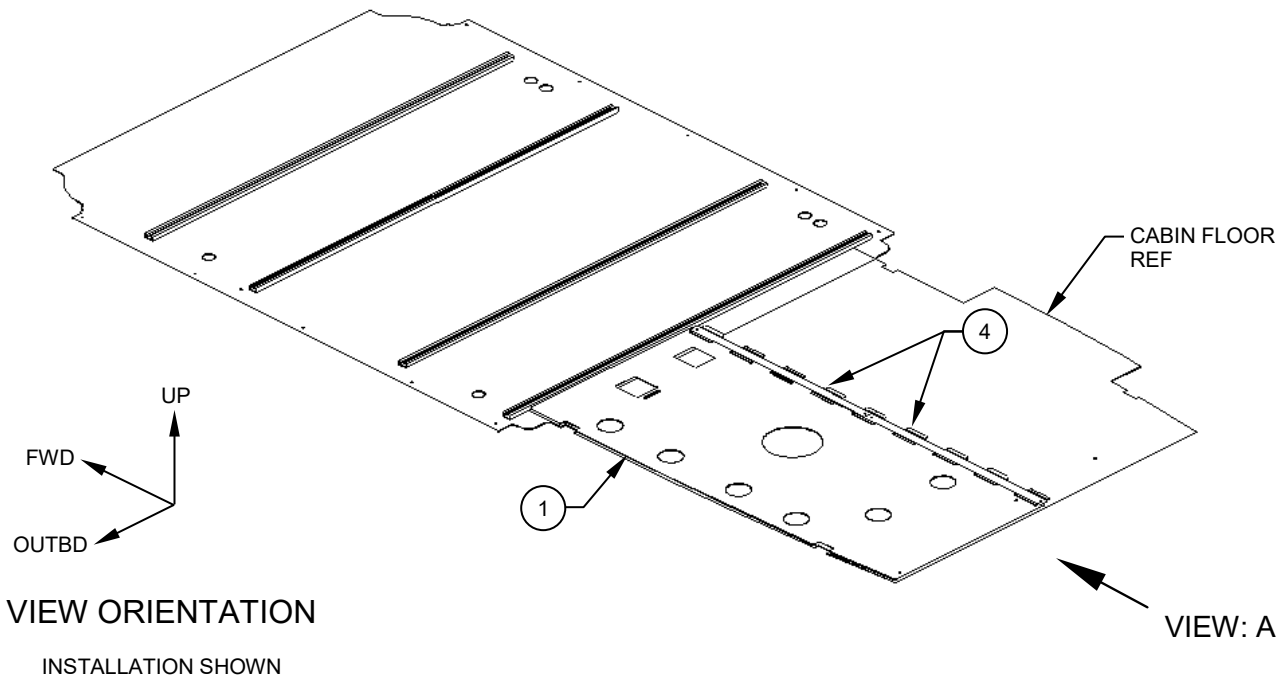

Figure 5
Some aircraft structure
Removed for clarity

Removal Instructions (cont.)

Floor Protection, Kit, AFT

1. Remove all components associated with the Floor Protection, Kit, AFT
2. Replace Screw, Washer Head (Item 9), with OEM fasteners.
3. For permanent removal, of the Floor Protection, Kit, AFT remove all bonded Velcro, Details. Peel and remove the Velcro®, Detail (Items 10 & 11) and clean off any residual adhesive. It is permitted to leave the Velcro®, Detail (Items 10 & 11) in place if the operator chooses.
4. Removal complete.
5. Perform a General Inspection of all items to ensure proper installation.
6. Update the aircraft logbook for the removal of Floor Protection, Kit AFT.

6.2 REPLACEMENT INSTRUCTIONS

Floor Protection, Kit, AFT

1. As there are no special considerations, the replacement of the Floor Protection, Kit, FWD can be considered the opposite of the removal.

6.3 REMOVAL INSTRUCTIONS

Floor Protection, Kit, AFT with OEM auxiliary fuel tank kit (429-706-500-101/-109)

1. Gain access to the AFT section of the cabin floor. Remove OEM auxiliary tank and attachment assemblies; rear attachment assemblies are integral to fuel tank. Fuel tank not shown for clarity. Reference Figure 6.

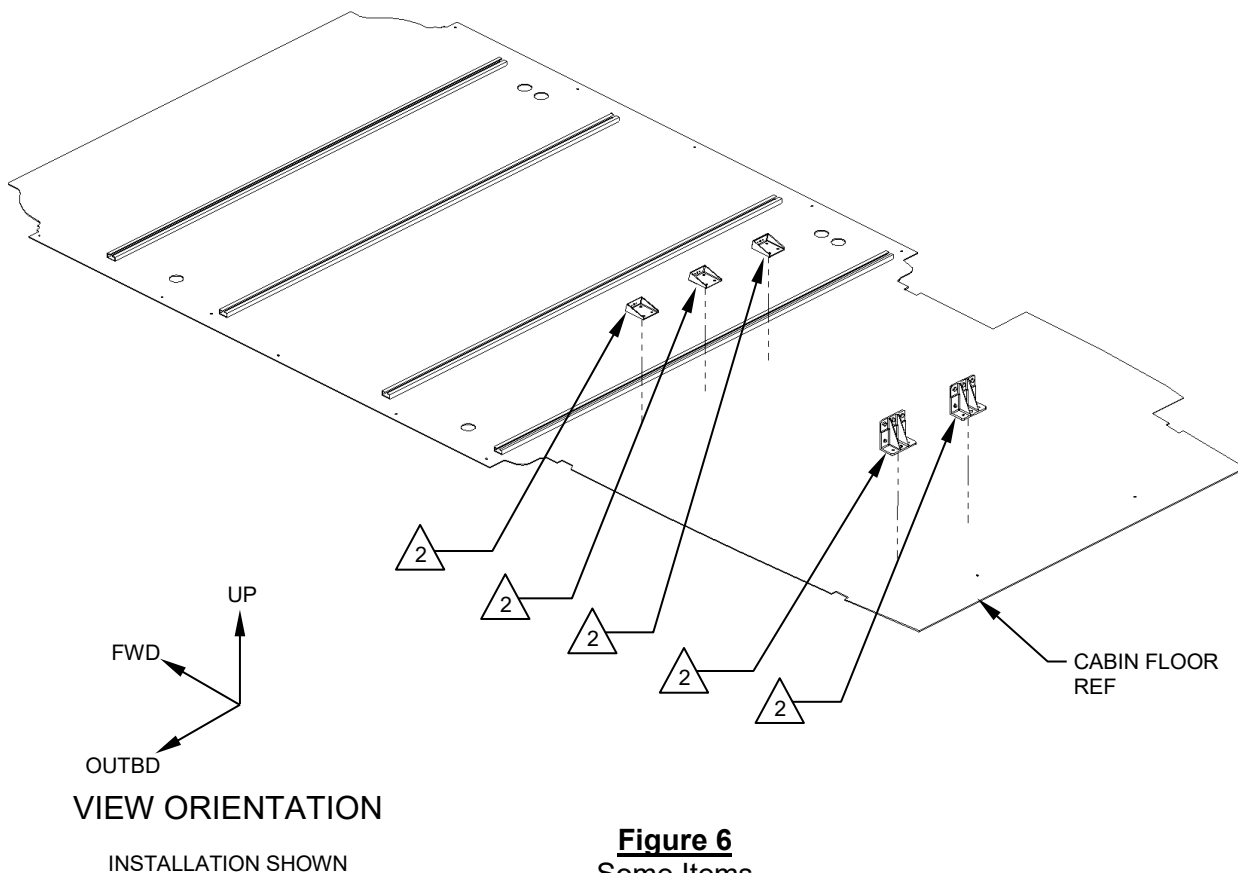

Removal Instructions (cont.)

Floor Protection, Kit, AFT with OEM auxiliary fuel tank kit (429-706-500-101/-109)

2. Remove the AFT two screws from the RHS FWD most triangular tie-down ring in the cargo area and remove the Retainer, Assemblies (Item 3) re-using the OEM fasteners. Reference Figure 7 and 8.

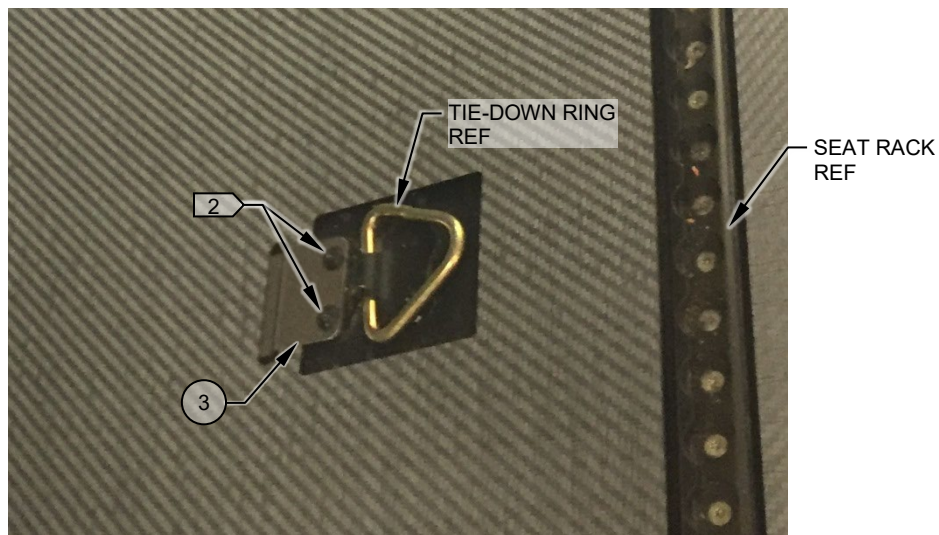
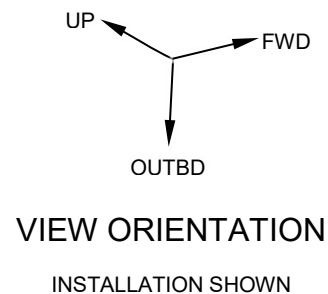

Figure 7
Installation Shown



Removal Instructions (cont.)

Floor Protection, Kit, AFT with OEM auxiliary fuel tank kit (429-706-500-101/-109)

3. Remove the 3X Spacer, Assy's (Item) from the tie-down locations. Re-install tie downs using OEM hardware. See Figure 8.
4. Remove the 2X Spacer Assy's (Item) in position under the fuel tank with the flat edge facing AFT and remove the provided fasteners (Item) in the slotted holes. Re-install tie downs using OEM hardware.

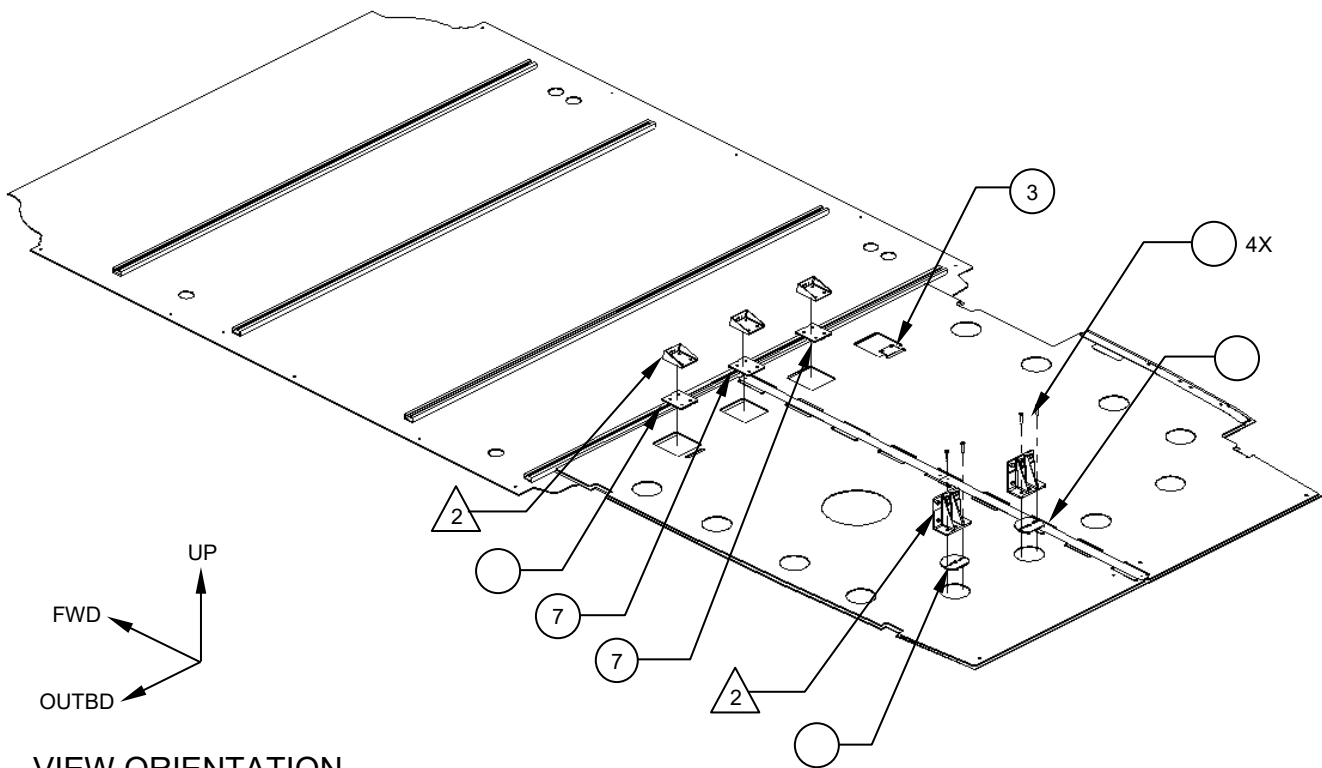
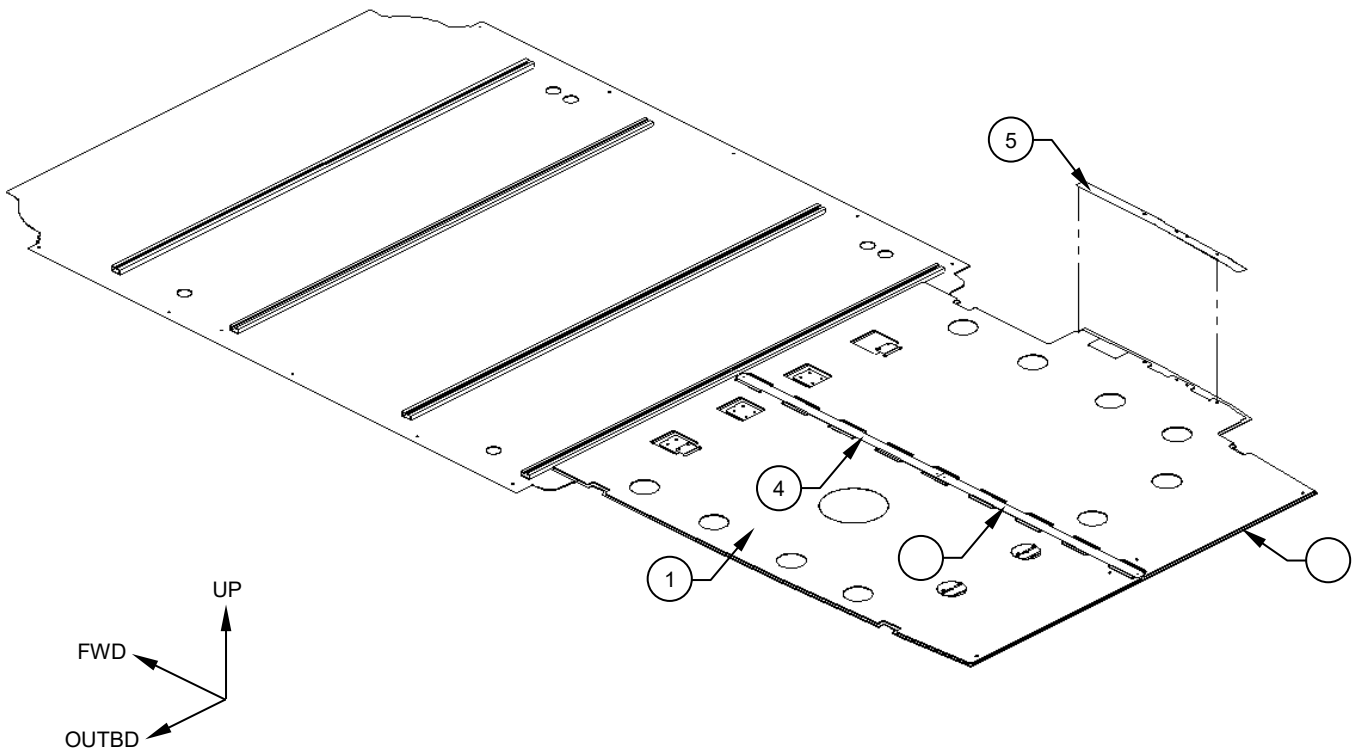

Figure 8
Some aircraft structure
Removed for clarity

Removal Instructions (cont.)

Floor Protection, Kit, AFT with OEM auxiliary fuel tank kit (429-706-500-101/-109)

1. Remove cargo door sill (Item) and re-install the OEM hardware. Remove the RHS Panel, Assy (Item 2) by tipping the panel on an angle and removing from the Retainer Strip, Assy (Item). Reference Figures 8, 9 & 10.



VIEW ORIENTATION

INSTALLATION SHOWN

Figure 9
Some aircraft structure
Removed for clarity

Removal Instructions (cont.)

Floor Protection, Kit, AFT with OEM auxiliary fuel tank kit (429-706-500-101/-109)

1. Remove the Retainer 2X Strip, Assy's (Item 4) by pulling the tabs out of the slots in the panel as shown. Reference Figures 10 & 11.

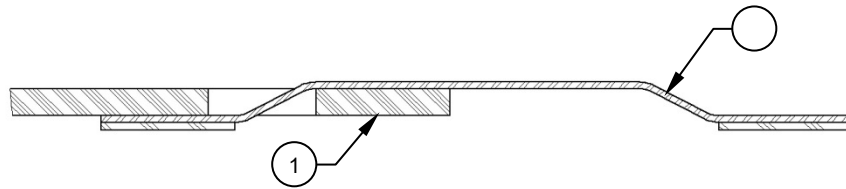

Figure 10
VIEW: A
Some aircraft structure
Removed for clarity

2. Remove the LHS Panel Assy (Item 1) from the floor as shown. Reference Figure 11.

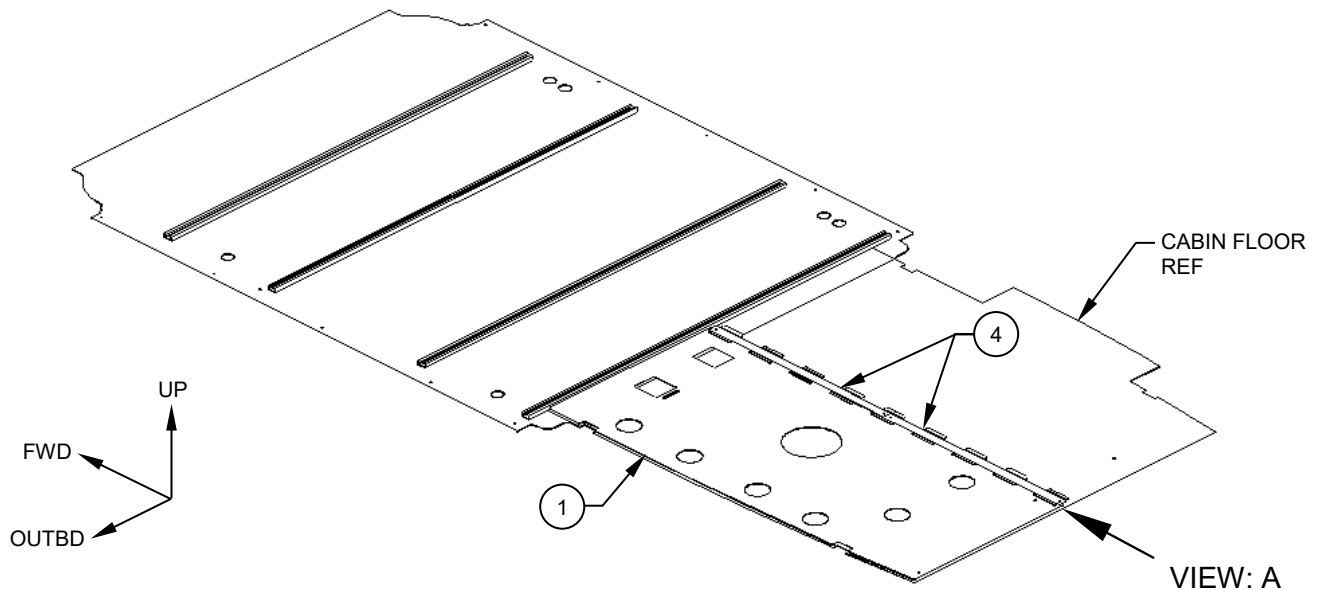
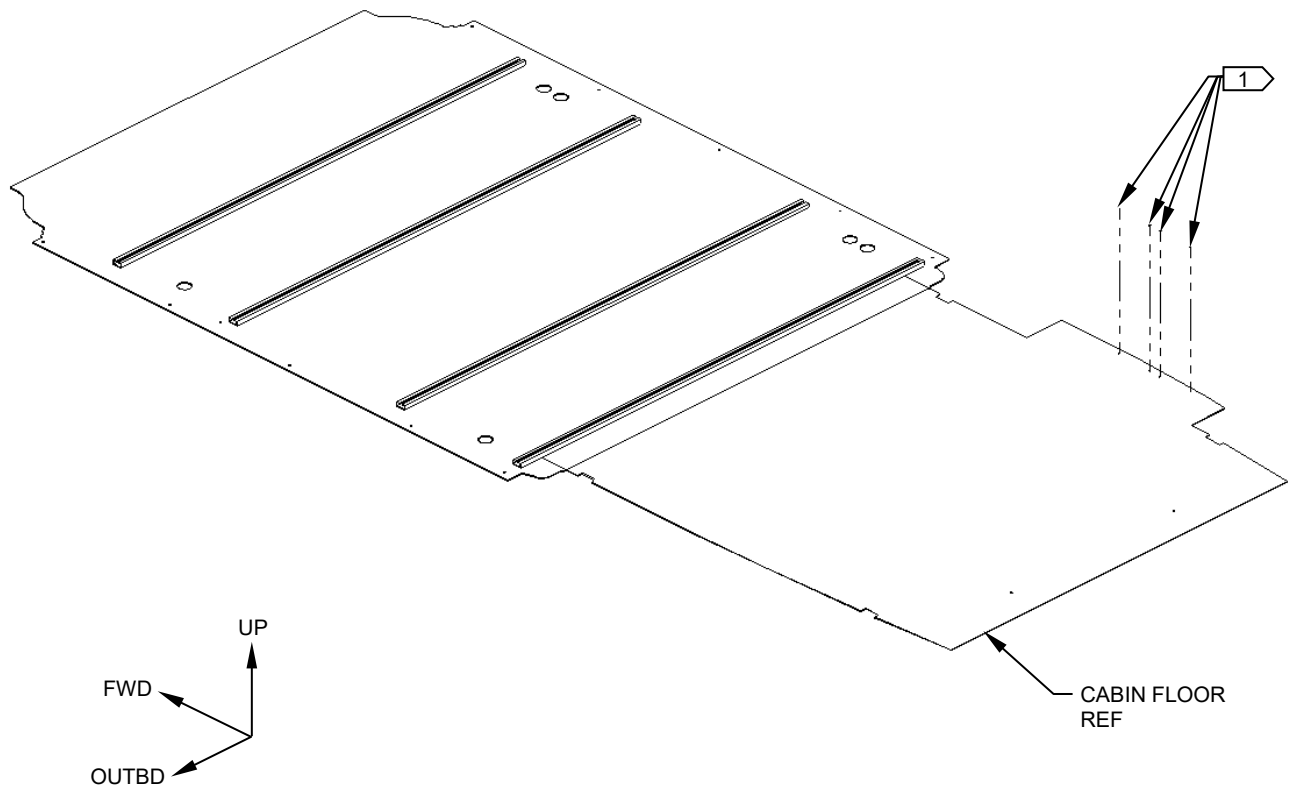

Figure 11
Some aircraft structure
Removed for clarity

Removal Instructions (cont.)

Floor Protection, Kit, AFT with OEM auxiliary fuel tank kit (429-706-500-101/-109)

1. Re-install OEM fasteners as shown. Reference Figure 12.



VIEW ORIENTATION

INSTALLATION SHOWN

Figure 12
Some aircraft structure
Removed for clarity

6.4 REPLACEMENT INSTRUCTIONS

Floor Protection, Kit, AFT with OEM auxiliary fuel tank kit (429-706-500-101/-109)

1. As there are no special considerations, the replacement of the Floor Protection, Kit, FWD can be considered the opposite of the removal.

SECTION 7 GENERAL

There are no general considerations for this kit.

SECTION 8 AIRWORTHINESS LIMITATIONS

The Airworthiness Limitations section is approved by the Minister and specifies maintenance required by any applicable airworthiness or operating rule unless an alternative program has been approved by the Minister.

The Airworthiness Limitations section is FAA approved and specifies maintenance required under Sections 43.16 and 91.403 of the Federal Aviation Regulations unless an alternative program has been FAA approved.

Supplement to applicable Maintenance Manual, Chapter 4, Airworthiness Limitations Schedule

Notes

1. Refer to the Maintenance Planning Information, Chapter 4, for general information on airworthiness limitations and airworthiness limitation schedules.
2. Item(s) **not** listed in the Scheduled Airworthiness Limitations section within this document have an unlimited airworthiness life.

Scheduled Airworthiness Limitations

1. There are no airworthiness limitations associated with the item(s) referenced within this document.

SECTION 9: ILLUSTRATED PARTS BREAKDOWN

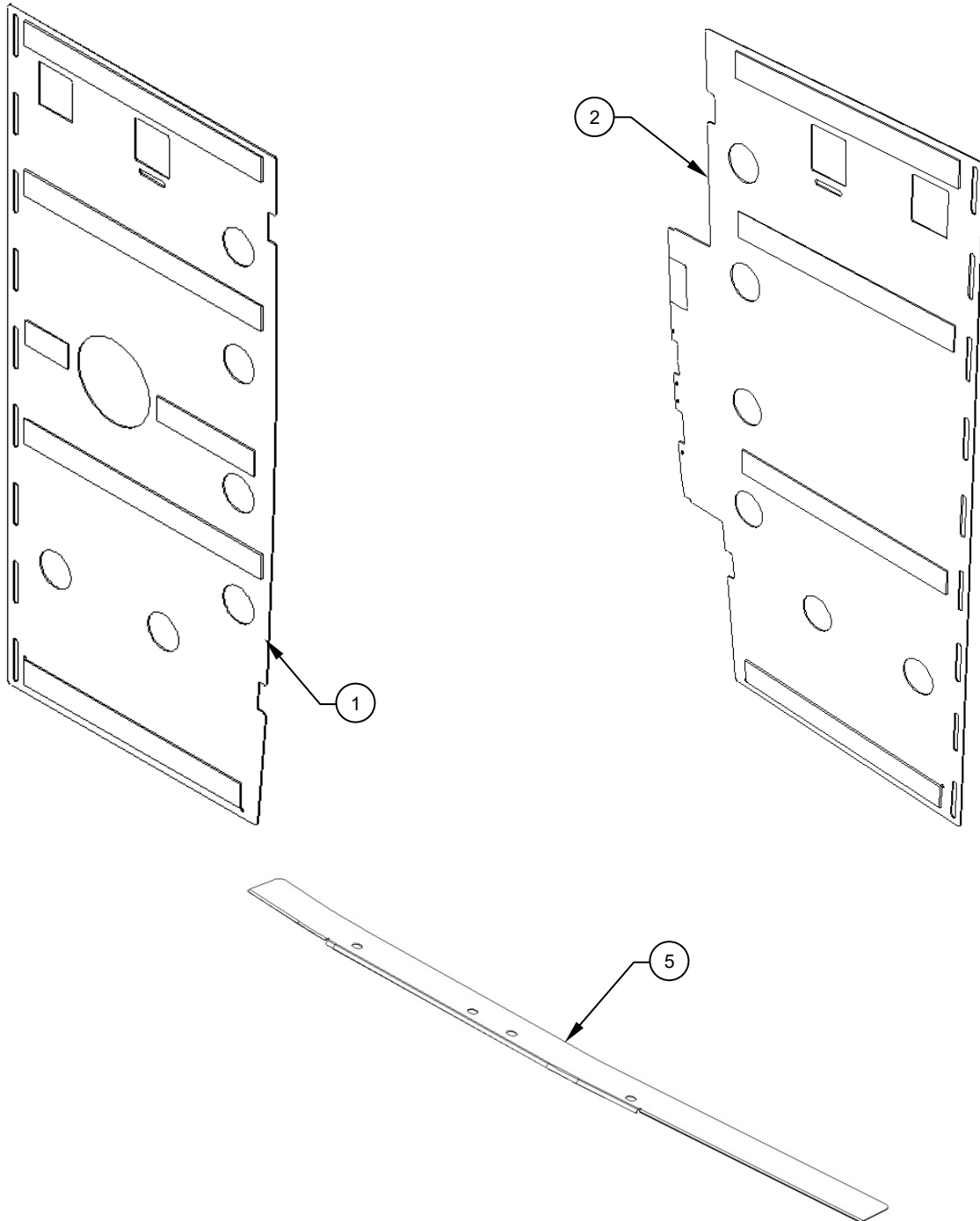

Illustrated Parts Breakdown (cont.)

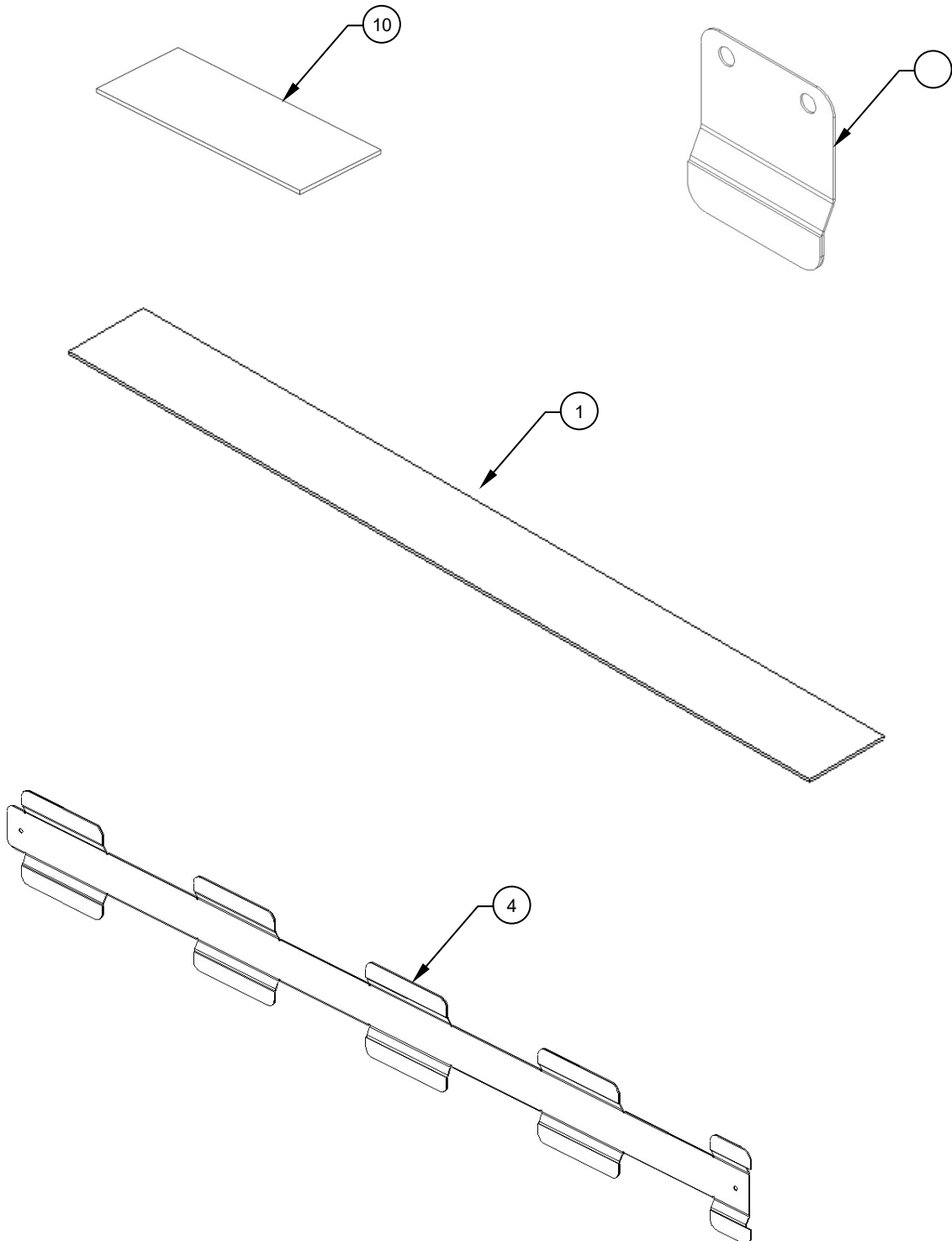

Illustrat

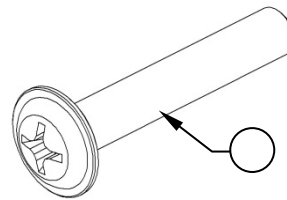
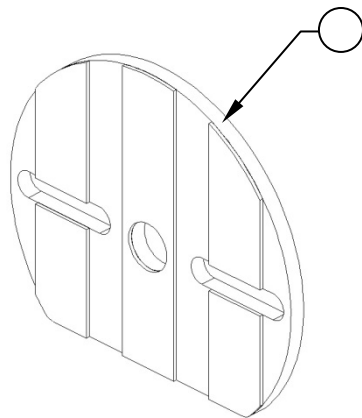
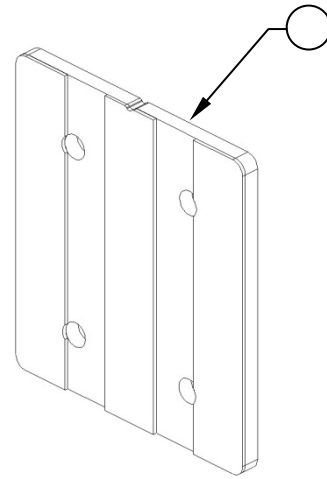
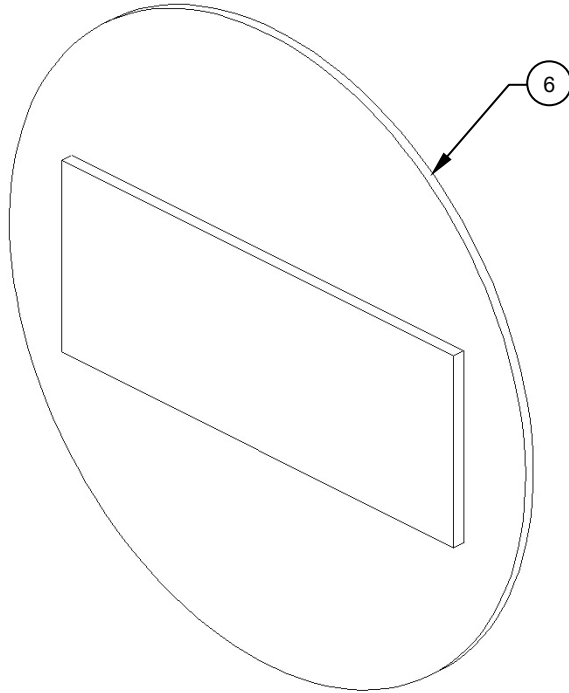

Illustrated Parts Breakdown (cont.)

ITEM	QTY	NUMBER	DESCRIPTION	MATERIAL	REF		FINISH	MANUFACTURER	NCAGEC
					STOCK SIZE	SPEC			
-	-	AAL-412-020-002	FLOOR PROTECTION, KIT, AFT	NA					
1	1	AAL-412-021-011	PANEL, ASSY, LHS	NA	NA	NA	NA	ALPINE AEROTECH LP	L0171
2	1	AAL-412-021-014	PANEL, ASSY, RHS	NA	NA	NA	NA	ALPINE AEROTECH LP	L0171
3	2	AAL-412-021-007	RETAINER, ASSY	NA	NA	NA	NA	ALPINE AEROTECH LP	L0171
4	2	AAL-412-021-008	RETAINER STRIP, ASSY	NA	NA	NA	NA	ALPINE AEROTECH LP	L0171
5	1	AAL-412-022-011	SILL, DETAIL	NA	NA	NA	NA	ALPINE AEROTECH LP	L0171
6	1	AAL-412-021-010	BLANKING PLATE, ASSY	NA	NA	NA	NA	ALPINE AEROTECH LP	L0171
7	3	AAL-412-021-012	SPACER, ASSY	NA	NA	NA	NA	ALPINE AEROTECH LP	L0171
8	2	AAL-412-021-013	SPACER, ASSY	NA	NA	NA	NA	ALPINE AEROTECH LP	L0171
9	4	AN525-832R16	SCREW, WASHER HEAD	SEE SPEC	SEE SPEC	NASM525	SEE SPEC	SOURCE AS REQUIRED	NA
10	1	151405	VELCRO, DETAIL	HOOK 88 BLACK 8289 PSA	2.00 X 5.00	SEE MFR	SEE MFR	VELCRO USA INC.	11153
11	2	151405	VELCRO, DETAIL	HOOK 88 BLACK 8289 PSA	2.00 X 20.00	SEE MFR	SEE MFR	VELCRO USA INC.	11153