

## **AS350/AS355 BEAR PAW, KIT INSTALLATION INSTRUCTIONS**

**MODELS: AIRBUS AS350 SERIES (H125) & AS355**

Read all of the Installation Instructions  
thoroughly prior to performing any activities relating to this product

---

**Table of Contents**

<u>Section</u>	<u>Description</u>	<u>Page</u>
1	Description	2
2	Installation & Removal Instructions	3
	Applicability	3
	Installation Instructions – OEM Skid Gear	6
	Installation Instructions – Dart Skid Gear	10
	Removal Instructions	12

**Notes**

1. If changes to this document are required, Alpine Aerotech LP shall revise all pages and reissue the entire document.
2. Alpine Aerotech LP shall make any subsequent revisions of this document available free of charge upon request. Alpine Aerotech LP also recommends that the end user of this product periodically verify the revision level of this document.

**SECTION 1      Description**

The following information provides a functional description of the AS350/AS355 Bear Paw, Kit as defined in Alpine Aerotech LP authority dataset AAL-390-030-001.

In soft terrain landing situations (i.e. tundra, snow and sand) where the skid tubes can sink into the landing area, balancing issues can occur and in rare cases the tail rotor can come in contact the ground. When installed, the Bear Paw, Kit provides additional flotation to the skid gear AFT of the aircraft's C of G, therefore increasing stability and decreasing the potential of a tail rotor strike.

## **SECTION 2**      **Installation & Removal Instructions**

### **Applicability**

The AS350/AS355 Bear Paw, Kit (AAL-390-030-001) is applicable to all AS350 (H125) & AS355 serial numbers.

### **Weight & Balance**

<u>Part Number</u>	<u>Description</u>	<u>Weight</u>	<u>Long. Arm</u>	<u>Lat. Arm</u>
AAL-390-030-001	Bear Paw, Kit †	17.20*	158.82	.00
		7.80 (Kg)	4034 (mm)	.00 (mm)
AAL-390-030-001	Bear Paw, Kit ‡	15.52*	158.58	.00
		7.04 (Kg)	4028 (mm)	.00 (mm)

† Applicable to installations with Grippers (Item 2) and associated hardware

‡ Applicable to installations without Grippers (Item 2) and associated hardware

\* Total increase in weight to aircraft.

### **General Notes**

- All Installation Instructions shall be accomplished in accordance with (IAW) standard aircraft practices. Refer to the current revision of the FAA Advisory Circular AC 43.13-1 and AC 43.13-2 for details on standard aircraft practices.
- Torque fasteners IAW the tension type torque limits indicated in the current revision of the FAA Advisory Circular AC 43.13-1, Table 7-1 unless otherwise specified.
- All Dimensions are in imperial measures (inches/pounds).
- Refer to ICA Section 3: Maintenance Manual Supplement for instructions on maintenance for the item(s) referenced within this section.
- Refer to ICA Section 6: Illustrated Parts Breakdown for the part numbers of the item(s) referenced within this section.

### **Installation Notes**

△<sub>1</sub> Typical item number for all like items in this view unless otherwise specified.

△<sub>2</sub> Apply Thread-locker (Item 17) to threads IAW manufacturer's recommendations (prior to torquing fastener).

## Installation Instructions – Common

1. Install the Grippers (Item 2) and supplied hardware on the Bear Paw, Detail (Item 1) as shown. Ensure all serrated surfaces on the Grippers are facing down (serrations must be common to the ground). Ensure Thread-locker (Item 17) is applied (mandatory). Torque all Gripper fasteners IAW General Note 2. Reference Figure 1.

**NOTE:** Installation of Grippers (Item 2) and associated hardware is optional. If Grippers are desired, all Grippers (8X) and associated hardware must be installed. Use applicable Weight & Balance information provided. If Grippers are not desired, all Grippers (8X) and associated hardware must be removed. Use applicable Weight & Balance information provided.

### CAUTION

Ensure Thread-locker (Item 17) is sufficiently applied to all Gripper fasteners. Omitting Thread-locker is not acceptable and will create a non-airworthy installation.

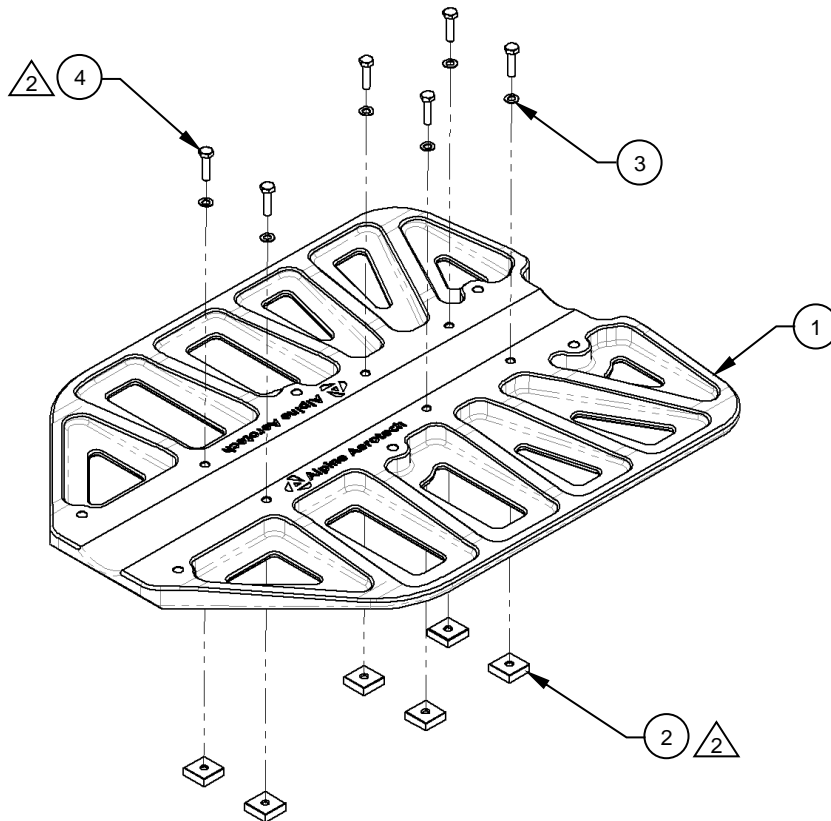

**Figure 1**  
Typical Gripper Installation

## Installation Instructions – Common

2. Install the supplied hardware on the Bear Paw, Detail (Item 1) as shown. Reference Figure 2.

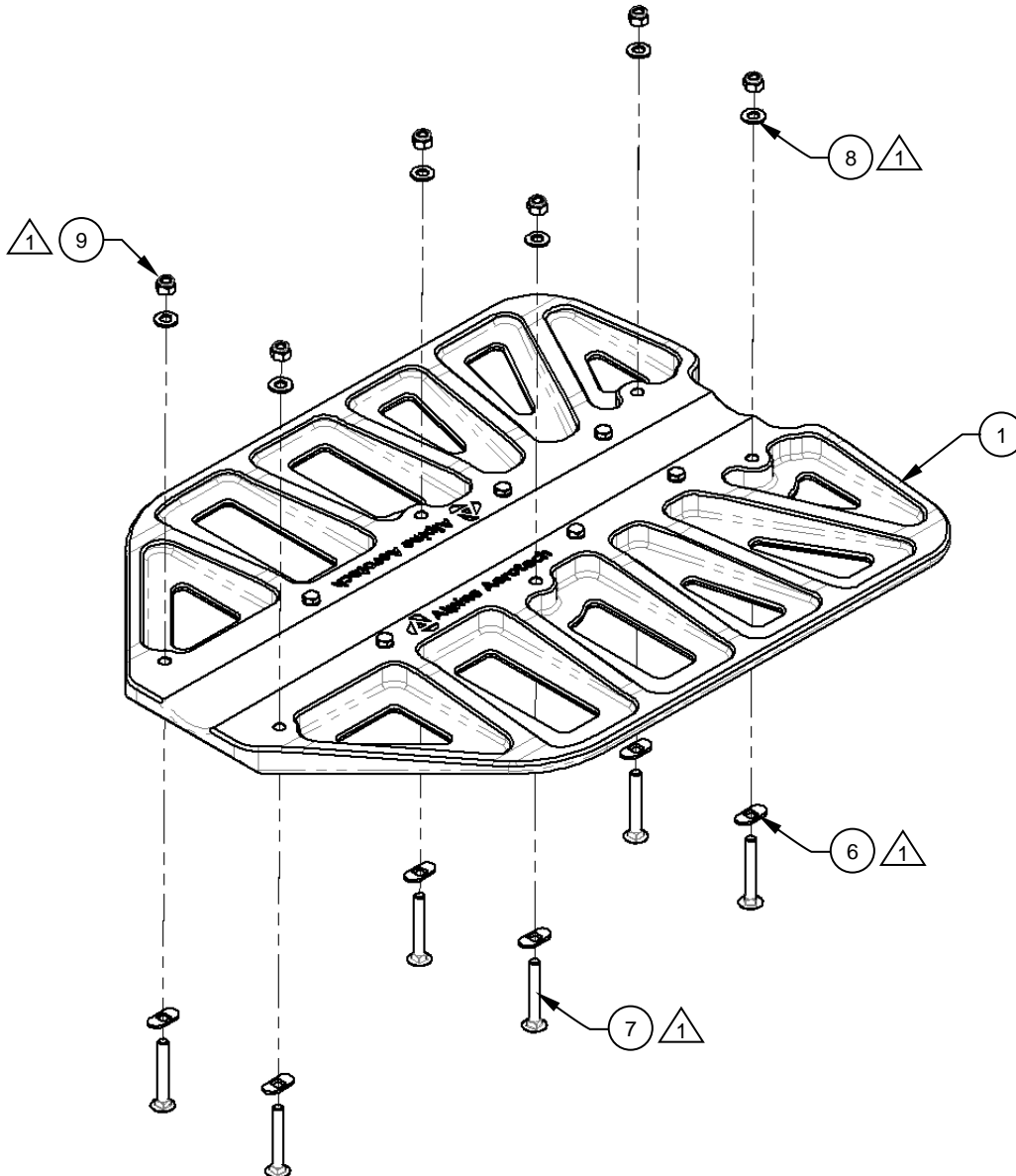

**Figure 2**  
Typical Hardware Installation

## Installation Instructions – OEM Skid Tube

1. Gain access to the aircraft and make the aircraft safe and ready for maintenance.
2. Raise the aircraft and remove the spring blade and associated fasteners. Install the Spacer, Detail (Item 13) between the spring blade and its associated fitting using the provided Bolt, Details (Item 14) and the associated nuts (Item 15). Re-use the existing washers. Reference Figure 3.

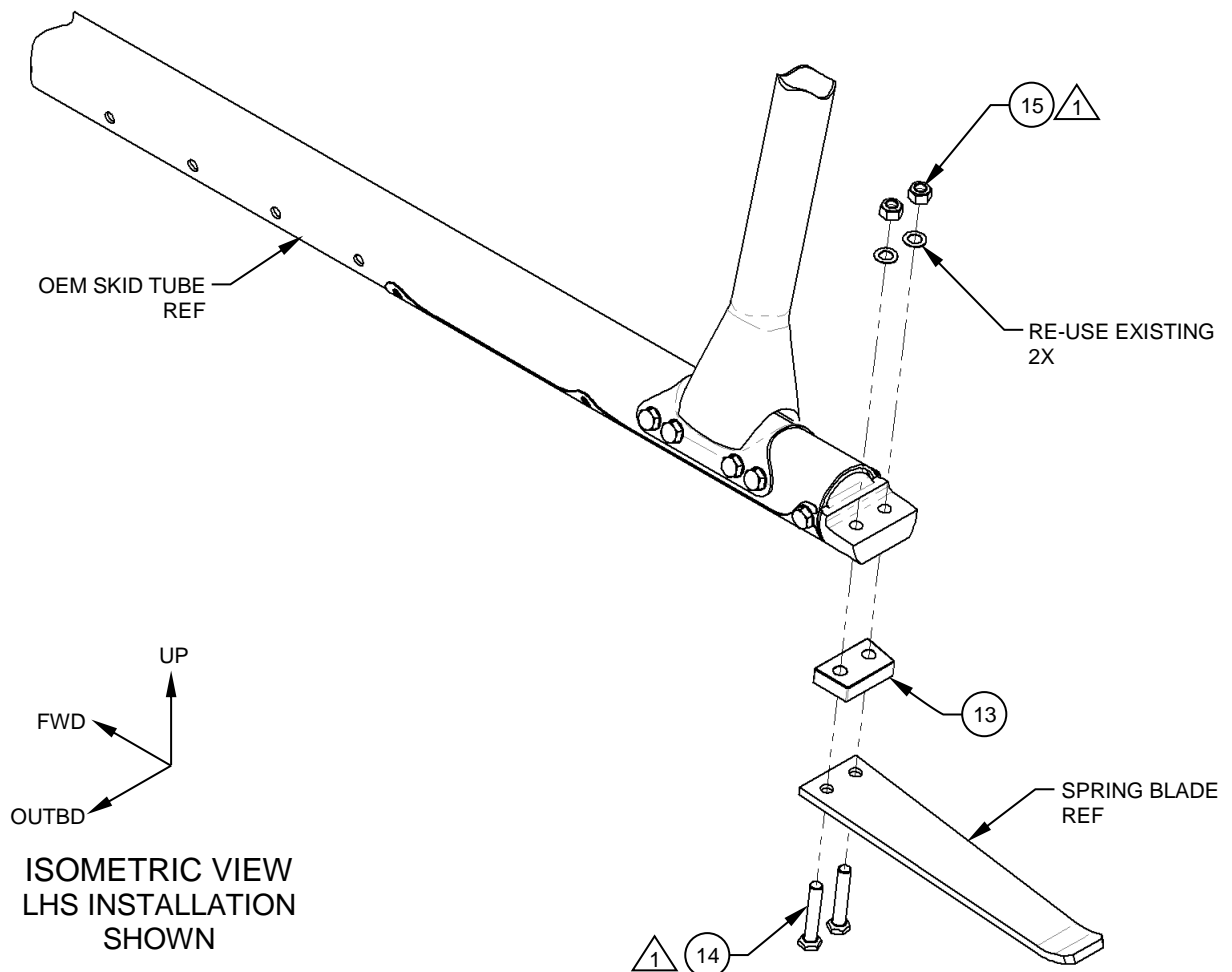

**Figure 3**  
 Spacer, Detail (Item 13)  
 OEM Installation shown

## Installation Instructions – OEM Skid Tube

- While the aircraft is raised, position the Bear Paw, Detail (Item 1) under the skid tube. Reference Figure 4.

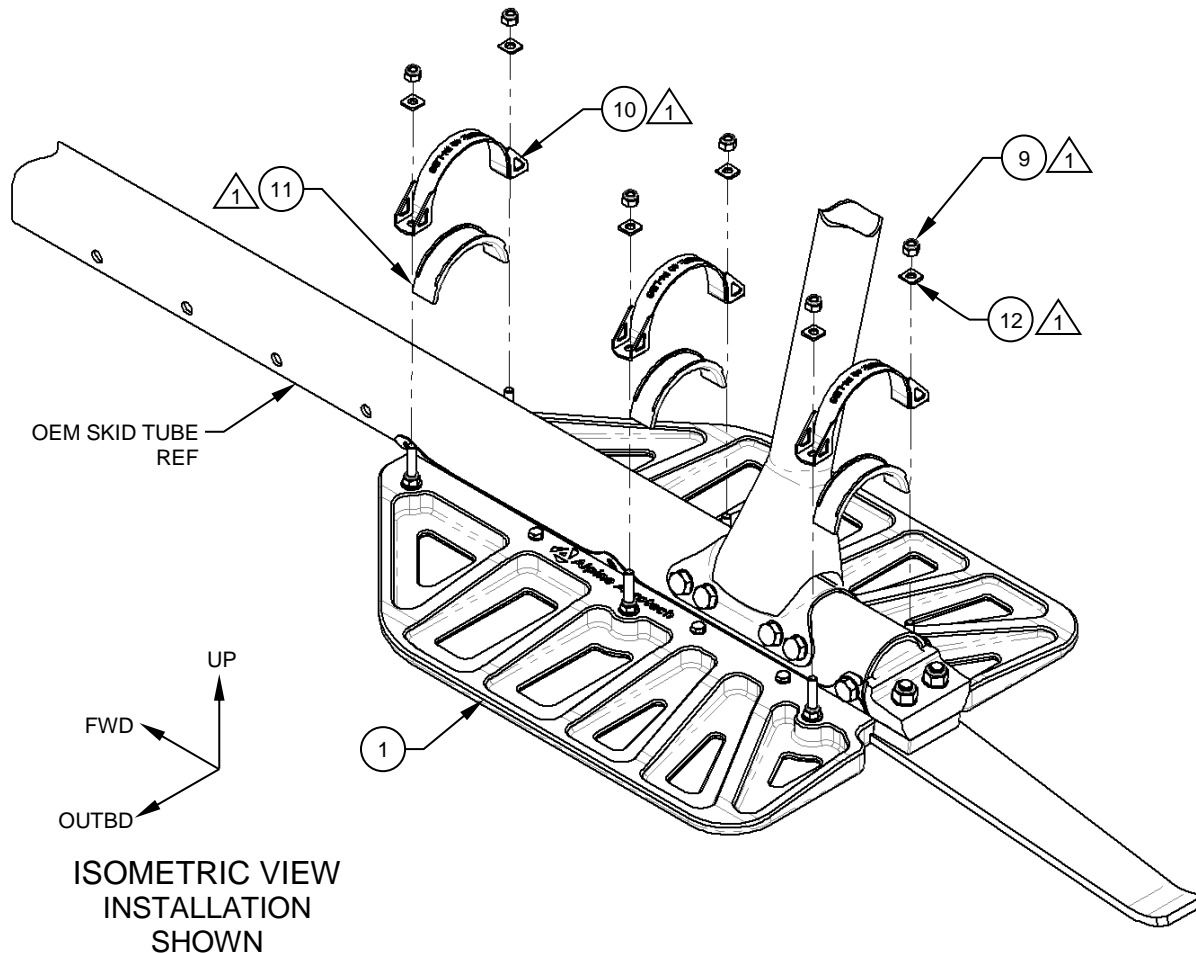

**Figure 4**  
 LHS Shown, RHS Opposite

- Once the Bear Paw, Detail (Item 1) is under the skid tube in its approximate location, place the Strap, Assys (Item 10) and their respective Cap, Details (Item 11) on their corresponding bolts. Reference Figure 4.

**NOTE:** Ensure the Aft-most Strap, Assy (Item 10) and associated Cap, Detail (Item 11) are positioned between the cross-tube saddle fitting and the existing bolt at the aft end of the skid tube. Reference Figure 4.

### Installation Instructions – OEM Skid Tube

5. Install the supplied Radius Washer (Item 12) and Nut (Item 9) on each bolt. Reference Figure 5. Ensure the radius edge on the Washer (Item 12) is oriented down and towards the skid tube. Reference Figure 5. A thin-wall socket may be required to adequately fasten the Nut (Item 9).

**NOTE:** Do not apply final torque to the fasteners at this stage while the aircraft is raised off the ground. Only apply minimal torque to snug-up the Bear Paw, Detail (Item 1). You should be able to slide the Bear Paw forward and aft by hand.

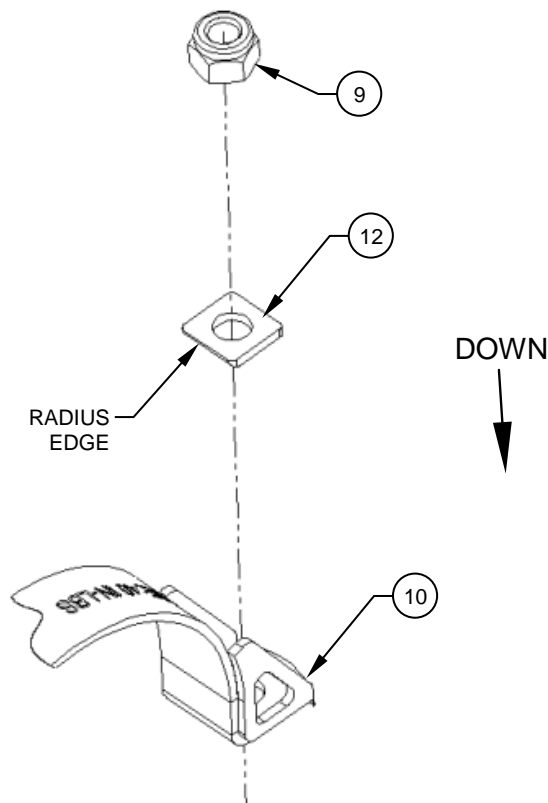

**Figure 5**  
Hardware Orientation Shown

6. Lower the aircraft onto the Bear Paw, Details (Item 1). After ensuring sufficient clearance between the Bear Paw, Details and the spring blade, torque the fasteners equally to 40 in/lbs. Reference Figure 4.



---

**Installation Instructions – OEM Skid Tube**

7. Install the Decal, Detail (Item 16) in a highly visible location on the instrument panel. Reference Figure 6.

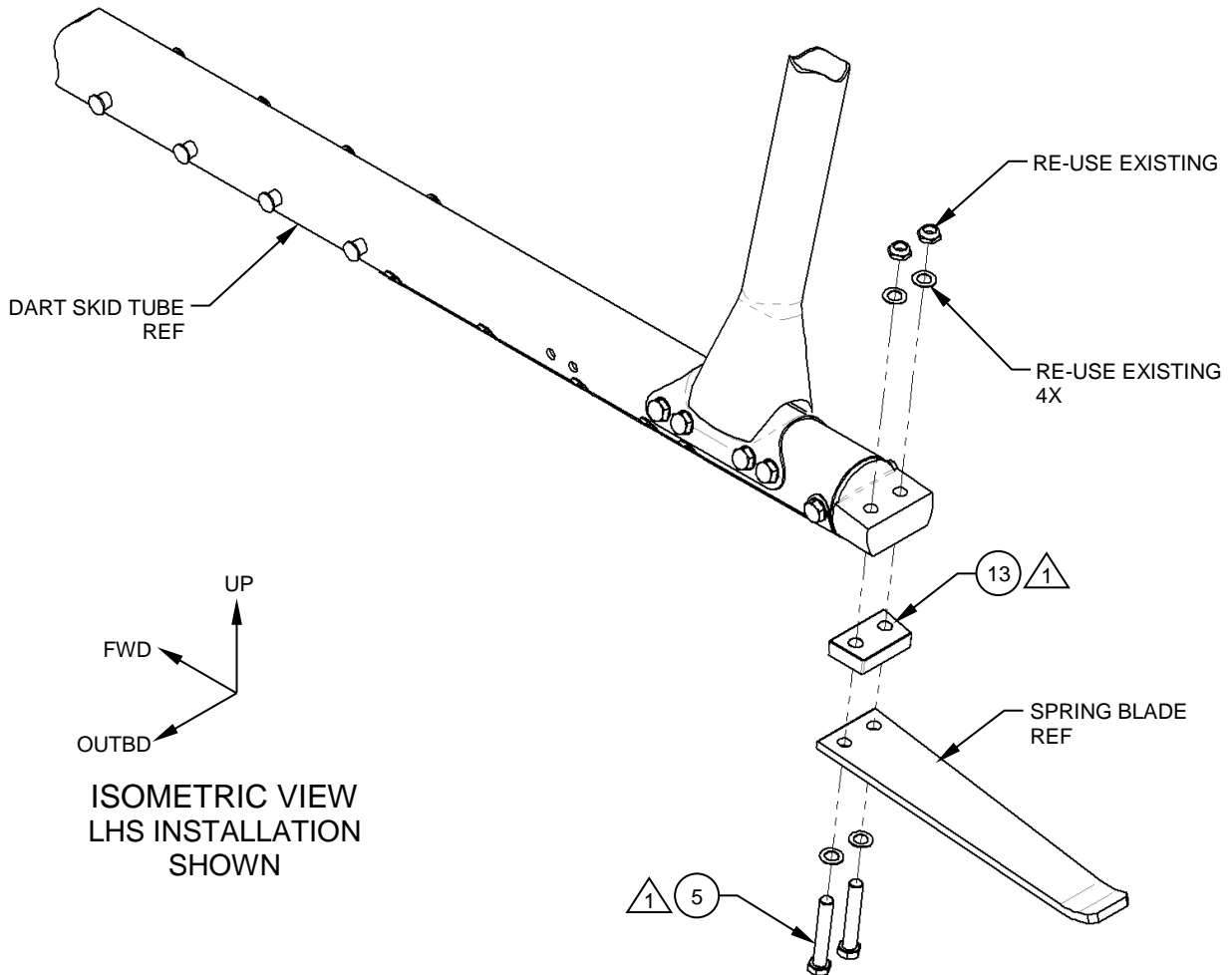

**Figure 6**  
Decal, Detail shown

8. Installation complete.
9. Perform a General Inspection of all items to ensure proper installation.
10. Update the aircraft logbook for the installation of the AS350/AS355 Bear Paw, Kit.

## Installation Instructions – Dart Skid Tube

1. All installation procedures associated to Dart skid tubes are the same as OEM skid tubes except for the following. Reference OEM Skid Tube Installation Steps 1 through 9.



**Figure 6**  
 Spacer, Detail (Item 13)  
 Dart Installation shown

2. Raise the aircraft and remove the spring blade and associated fasteners. Install the Spacer, Detail (Item 13) between the spring blade and its associated fitting using the provided Bolts (Item 5). Re-use the existing washers and nuts. Reference Figure 6.

### **Installation Instructions – Dart Skid Tube**

3. Installation complete.
4. Perform a General Inspection of all items to ensure proper installation.
5. Update the aircraft logbook for the installation of the AS350/AS355 Bear Paw, Kit.

---

**Removal Instructions**

1. As there are no special considerations or additional steps to remove the AS350/AS355 Bear Paw, Kit for either inspections, or mission configuration, the removal of the AS350/AS355 Bear Paw, Kit can be considered the opposite of installation.
2. Perform a General Inspection of all items to ensure proper removal.
3. Update the aircraft logbook for the removal of the Bear Paw, Kit.