

# **BEAR PAW, KIT INSTRUCTIONS FOR CONTINUING AIRWORTHINESS**

## **MODELS: BELL 505**

Read all of the Instructions for Continuing Airworthiness thoroughly prior to performing any activities relating to this product

## Table of Contents

<u>Section</u>	<u>Description</u>	<u>Page</u>
1	Description	2
2	Maintenance Manual Supplement	3
3	Installation & Removal Instructions	8
	Applicability	8
	Installation Instructions – Low Skid Gear	9
	Installation Instructions – High Skid Gear	14
	Removal Instructions	16
4	Illustrated Parts Breakdown	17

## Notes

1. If changes to this document are required, Alpine Aerotech LP shall revise all pages and reissue the entire document.
2. Alpine Aerotech LP shall make any subsequent revisions of this document available free of charge upon request. Alpine Aerotech LP also recommends that the end user of this product periodically verify the revision level of this document.

## SECTION 1      **Description**

The following information provides a functional description of the Bear Paw, Kit as defined in Alpine Aerotech LP authority dataset AAL-390-020-001.

- In soft terrain landing situations (i.e. tundra, snow and sand) where the skid tubes can sink into the landing area, balancing issues can occur and in rare cases the tail rotor can strike the ground.
- When installed, the Bear Paw, Kit provides additional flotation to the skid gear AFT of the aircraft's C of G, therefore increasing stability and decreasing the potential of a tail rotor strike.

## **SECTION 2      Maintenance Manual Supplement**

### **General Notes**

1.      The following information defines the instructions for continuing airworthiness, repair allowances and airworthiness limitations for the item(s) referenced within this document.
2.      Refer to the current revision of the BHT 505 Maintenance Manual for the chapter(s) and section(s) referenced within this document.
3.      Refer to the Section 3: Installation & Removal Instructions and Section 4: Illustrated Parts Breakdown for the replacement and/or installation of the item(s) referenced within this section.
4.      Scheduled inspection for the item(s) referenced within this document shall be accomplished in accordance with (IAW) the Inspection Procedures specified.
5.      Repair allowances for the item(s) referenced within this document shall be accomplished IAW the Repair Procedures specified.
6.      Limitations for the item(s) referenced within this document are IAW the Airworthiness Limitations specified.

---

## Airworthiness Limitations

The Airworthiness Limitations section is approved by the Minister and specifies maintenance required by any applicable airworthiness or operating rule unless an alternative program has been approved by the Minister.

The Airworthiness Limitations section is FAA approved and specifies maintenance required under Sections 43.16 and 91.403 of the Federal Aviation Regulations unless an alternative program has been FAA approved.

## **Supplement to applicable BHT 505 Maintenance Manual, Chapter 04, Worthiness Limitations**

### Notes

1. Refer to the applicable BHT 505 Maintenance Manual, Chapter 04 - Worthiness Limitations, for general information on airworthiness limitations and airworthiness limitation schedules.
2. Item(s) **not** listed in the Scheduled Airworthiness Limitations section within this document have an unlimited airworthiness life.

### Scheduled Airworthiness Limitations

1. There are no airworthiness limitations associated with the item(s) referenced within this document.

## **Inspection Procedures**

### **Supplement to applicable BHT 505 Maintenance Manual, Chapter 05, Scheduled/Unscheduled Maintenance**

#### **Notes**

1. Refer to the applicable BHT 505 Maintenance Manual, Chapter 05 - Scheduled/Unscheduled Maintenance as applicable, for general information on inspections, inspection definitions, inspection intervals, inspection methods and inspection schedules.
2. General Inspections, as indicated within this document, are defined as visual, non-thorough checks.
3. Detailed Inspections, as indicated within this document, are defined as visual and thorough, searching checks.
4. Perform Daily/Pre-Flight Inspections every day, prior to flight operation. If damage is detected, perform the 300 Hour/12 Month Inspections.
5. Perform 300 Hour/12 Month Inspections every 300 hours or every 12 months, whichever occurs first, prior to flight operation. If damage is detected, refer to the Repair Procedures section within this document.

## Scheduled Inspections

### 1. Daily/Pre-Flight Inspections

Data Reference: Section 3: Installation and Removal Instructions  
Section 4: Illustrated Parts Breakdown

- i. Perform a General Inspection on all items in the Bear Paw, Kit for general condition.
- ii. Perform a General Inspection on all items in the Bear Paw, Kit for proper security.
- iii. Visually confirm the condition of the torque lacquer on the nuts securing the Bear Paw to the skid-tube. If the torque lacquer is broken, perform the 300 hour/12-month inspection.

### 2. 300 Hour/12 Month Inspections

Data Reference: Section 3: Installation and Removal Instructions  
Section 4: Illustrated Parts Breakdown

- i. Perform a Detailed Inspection on all items, materials and finishes in the Bear Paw, Kit for evidence of corrosion, cracks and damage.
- ii. Perform a Detailed Inspection on all items in the Bear Paw, Kit for evidence of excessive wear.
- iii. Perform a Detailed Inspection on all items, materials and finishes in the Bear Paw, Kit for proper integrity and condition.
- iv. Perform a Detailed Inspection on all hardware and fasteners in the Bear Paw, Kit for proper security and torque.

## **Repair Procedures**

1. Repairs to the item(s) referenced within this document are **not** permitted. Contact Alpine Aerotech LP for further information if repairs are required to the item(s) referenced within this document.

## **SECTION 3**      **Installation & Removal Instructions**

### **Applicability**

The Bear Paw, Kit (AAL-390-020-001) is applicable to all serial numbers.

### **Weight & Balance**

<u>Part Number</u>	<u>Description</u>	<u>Weight</u>	<u>Long. Arm</u>	<u>Lat. Arm</u>
AAL-390-020-001	Bear Paw, Kit †	17.99* 8.16 (Kg)	184.232 4.68 (m)	.000 .00 (m)
AAL-390-020-001	Bear Paw, Kit ‡	17.02* 7.72 (Kg)	184.848 4.70 (m)	.000 .00 (m)

† Applicable to installations with Grippers (Item 11) and associated hardware

‡ Applicable to installations without Grippers (Item 11) and associated hardware

\* Total increase in weight to aircraft.

### **General Notes**

- All Installation Instructions shall be accomplished in accordance with (IAW) standard aircraft practices. Refer to the current revision of the FAA Advisory Circular AC 43.13-1 and AC 43.13-2 for details on standard aircraft practices.
- Torque fasteners IAW the tension type torque limits indicated in the current revision of the FAA Advisory Circular AC 43.13-1, Table 7-1 plus tare torque, unless otherwise specified. Tare torque is defined as the amount of torque required to overcome the resistance of self-locking nuts against mating bolts or studs.
- All Dimensions are in imperial measures (inches/pounds).
- Refer to Section 2: Maintenance Manual Supplement for instructions on maintenance for the item(s) referenced within this section.
- Refer to Section 4: Illustrated Parts Breakdown for the part numbers of the item(s) referenced within this section.

### **Installation Notes**

- △<sub>1</sub> Typical item number for all like items in this view unless otherwise specified.
- △<sub>2</sub> Apply Threadlocker (Item 15) to threads IAW manufacturer's recommendations (prior to torquing fastener). Torque to 30-35 INCH LBS.
- △<sub>3</sub> Apply Torque Lacquer (Item 17) or equivalent, to Nut, Hex, Self-locking (Item 10) and Bolt, Round Head, Square Neck (Items 8 & 9) common to Strap, Assys only (Item 3) per manufacturer's recommendations.

**Installation Instructions – Common**

**NOTE:** LHS installation shown, RHS opposite.

1. Install the Grippers (Item 11) and supplied hardware on the Bear Paw, Detail (Item 1) as shown. Ensure all serrated surfaces on the Grippers are facing down (serrations must be common to the ground). Ensure Threadlocker (Item 15) is applied (mandatory). Torque all Gripper fasteners IAW General Note 2. Reference Figure 1.

**NOTE:** Installation of Grippers (Item 11) and associated hardware is optional.

If Grippers are desired, all Grippers (8X) and associated hardware must be installed. Use applicable Weight & Balance data accordingly.

If Grippers are not desired, all Grippers (8X) and associated hardware must be removed. Use applicable Weight & Balance data accordingly.

**CAUTION:** Ensure Threadlocker (Item 15) is sufficiently applied to all Gripper fasteners. Omitting Threadlocker is not acceptable and will create a non-airworthy installation.

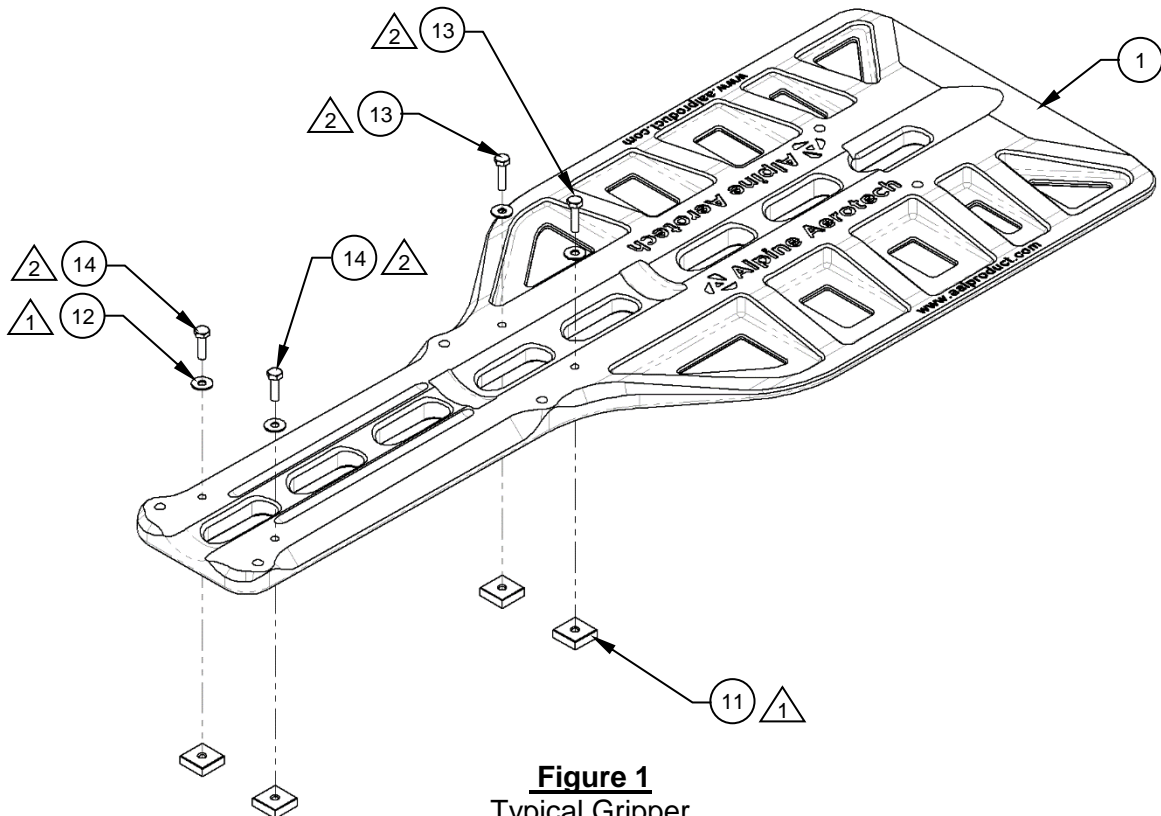

**Figure 1**  
Typical Gripper  
Installation

**Installation Instructions – Common**

- Install the supplied hardware on the Bear Paw, Detail (Item 1) as shown. Reference Figure 2.

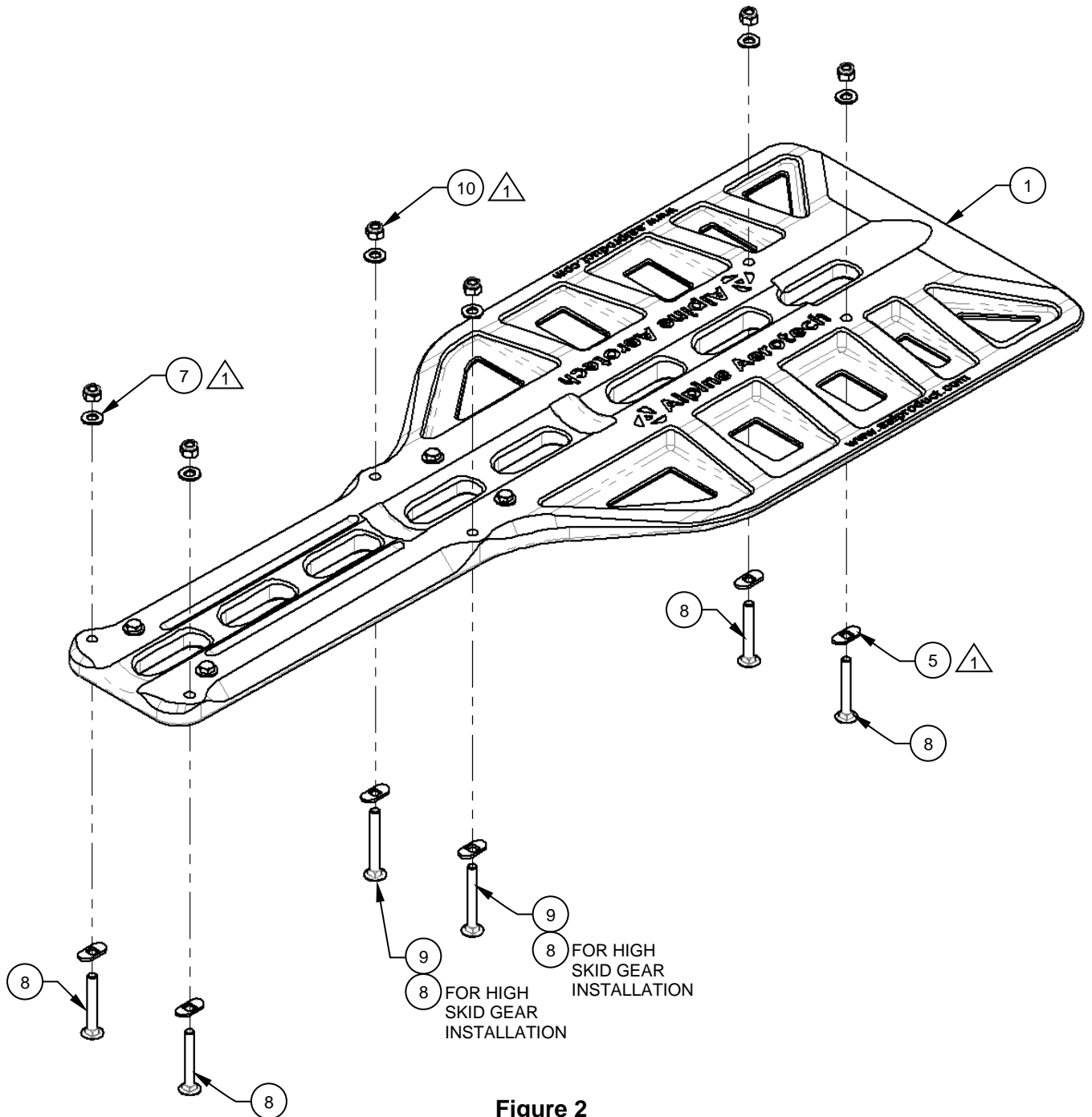

**Figure 2**  
Typical Hardware  
Installation

**Installation Instructions – Low Skid Gear**

1. Raise the aircraft so the Bear Paw, Detail (Item 1) can be slid under the skid tube. Reference Figure 3.

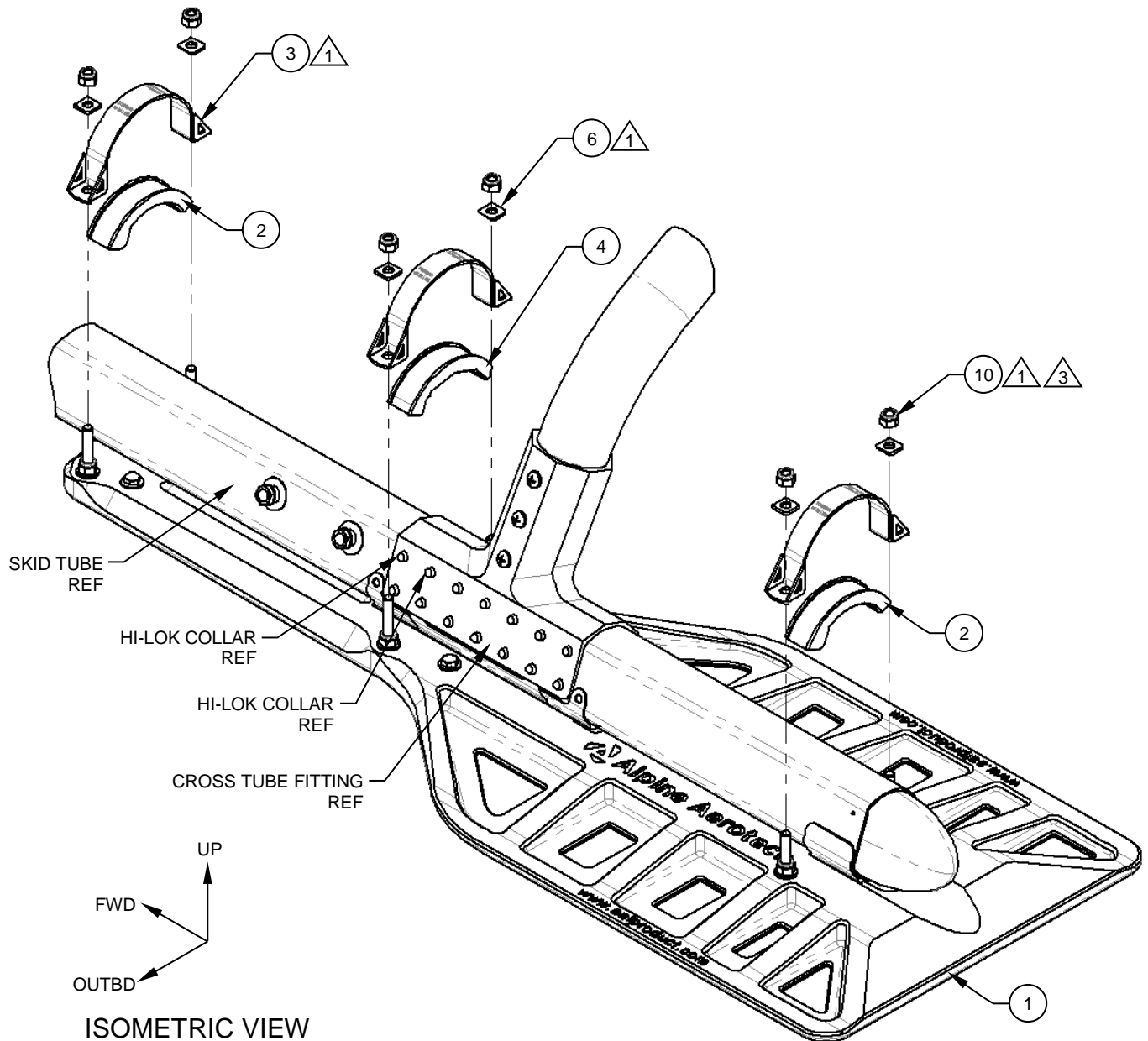

ISOMETRIC VIEW  
LHS INSTALLATION  
SHOWN

**Figure 3**  
LHS Shown  
RHS Opposite

**Installation Instructions – Low Skid Gear**

2. Once the Bear Paw, Detail (Item 1) is under the skid tube in its approximate location, place the Strap, Assys (Item 3) and their respective Cap, Details (Items 2 & 4) on their corresponding bolts. Reference Figure 3.

**NOTE:** Ensure the Cap, Detail (Item 4) is oriented between the two forward Hi-Lok Collars common to the cross tube fitting.

**NOTE:** Ensure the Cap, Details (Item 2 & 4) are oriented properly on top of the skid tube and cross tube fitting.

3. Install the supplied Washer (Item 6) and Nut (Item 10) on each bolt. Reference Figure 3.

**NOTE:** Ensure the radius edge on the Washer (Item 6) is oriented down and towards the skid tube. Reference Figure 4.

**NOTE:** A “thin-wall” socket may be required to adequately engage the Nut (Item 10).

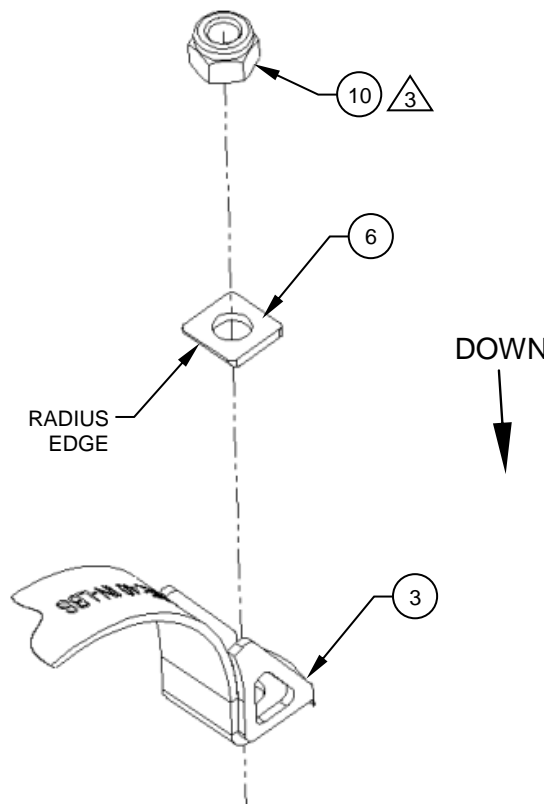

**Figure 4**

### **Installation Instructions – Low Skid Gear**

**CAUTION:** Do **NOT** apply full torque to the fasteners at this stage while the aircraft is raised off the ground. Only apply minimal torque to snug-up the Bear Paw, Detail (Item 1).

4. Lower the aircraft onto the Bear Paw, Details (Item 1) and torque the fasteners equally to 40 in/lbs. (plus tare torque). Reference Figure 3.

**CAUTION:** Before applying torque, ensure the Cap, Detail (Item 4) is oriented between the two forward Hi-Lok Collars common to the cross tube fitting. Reference Step 4.

5. Installation complete.
6. Perform a General Inspection of all items to ensure proper installation.
7. Update the aircraft logbook for the installation of the Bear Paw, Kit.

## Installation Instructions – High Skid Gear

1. Raise the aircraft so the Bear Paw, Detail (Item 1) can be slid under the skid tube. Reference Figure 5.

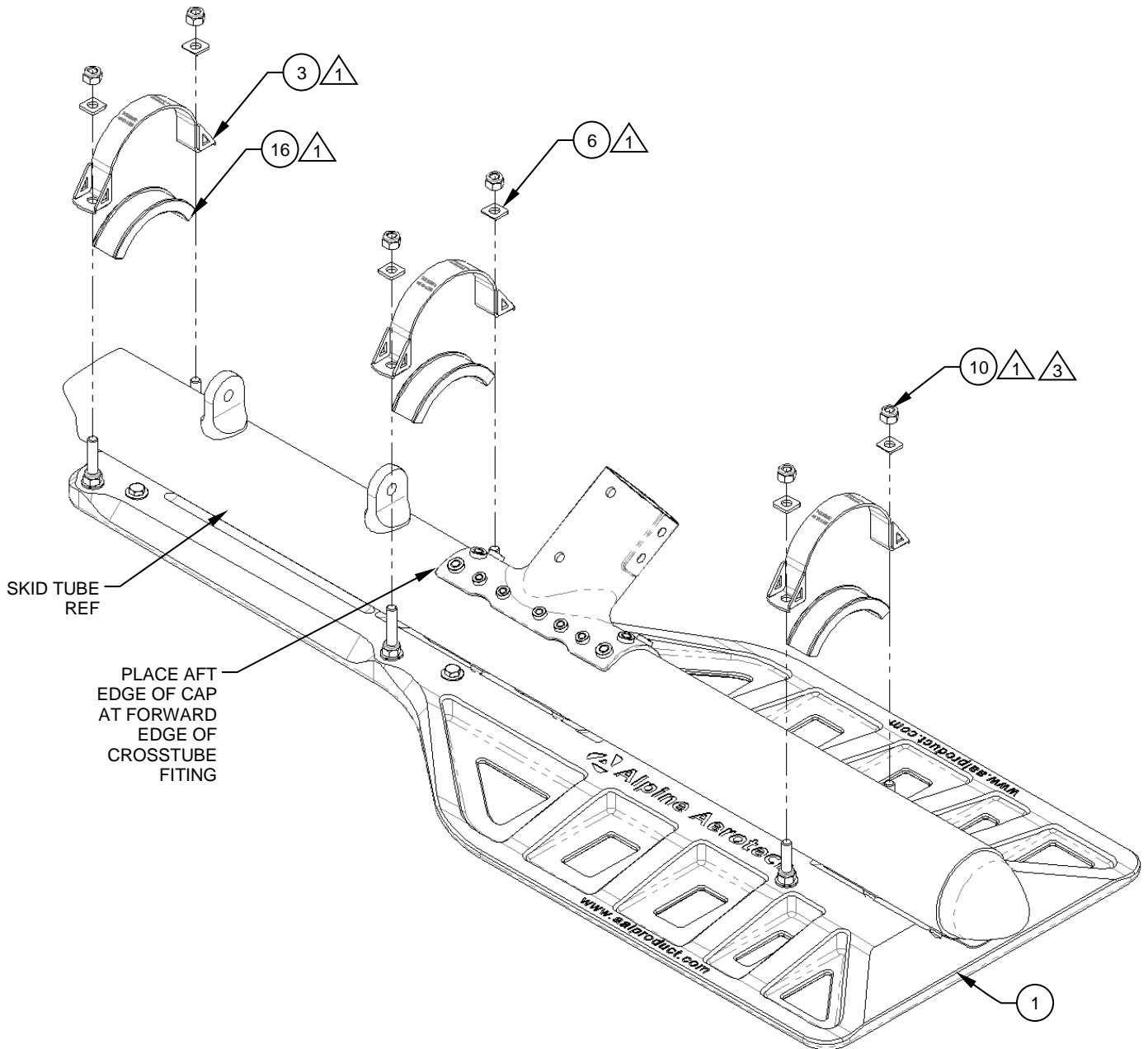

**Figure 5**

---

## **Installation Instructions – High Skid Gear**

2. Once the Bear Paw, Detail (Item 1) is under the skid tube in its approximate location, place the Strap, Assys (Item 3) and their respective Cap, Details (Item 16) on their corresponding bolts. Reference Figure 5.

**NOTE:** Ensure the Cap, Details (Item 16) are oriented properly on top of the skid tube and cross tube fitting.

3. Install the supplied Washer (Item 6) and Nut (Item 10) on each bolt. Reference Figure 5.

**NOTE:** Ensure the radius edge on the Washer (Item 6) is oriented down and towards the skid tube. Reference Figure 4.

**NOTE:** A “thin-wall” socket may be required to adequately engage the Nut (Item 10)

**CAUTION:** Do **NOT** apply full torque to the fasteners at this stage while the aircraft is raised off the ground. Only apply minimal torque to snug-up the Bear Paw, Detail (Item 1).

4. Lower the aircraft onto the Bear Paw, Details (Item 1) and torque the fasteners equally to 40 in/lbs. (plus tare torque). Reference Figure 3.

**CAUTION:** Before applying torque, ensure the Cap, Detail (Item 4) is oriented between the two forward Hi-Lok Collars common to the cross-tube fitting. Reference Step 4.

5. Installation complete.
6. Perform a General Inspection of all items to ensure proper installation.
7. Update the aircraft logbook for the installation of the Bear Paw, Kit.

## **Removal Instructions- Common**

1. As there are no special considerations or additional steps to remove the Bear Paw, Kit for either inspections, or mission configuration, the removal of the Bear Paw, Kit can be considered the opposite of installation.
2. Perform a General Inspection of all items to ensure proper removal.
3. Update the aircraft logbook for the removal of the Bear Paw, Kit.

## **Section 4      Illustrated Parts Breakdown**

### **General Notes**

1.      Alternate items listed where applicable.

 Typical item number for all like items in this view unless otherwise specified.

 Threadlocker (Item 15) and Torque Lacquer (Item 17) not shown and not supplied. Procure locally. |

**Illustrated Parts Breakdown** (cont.)

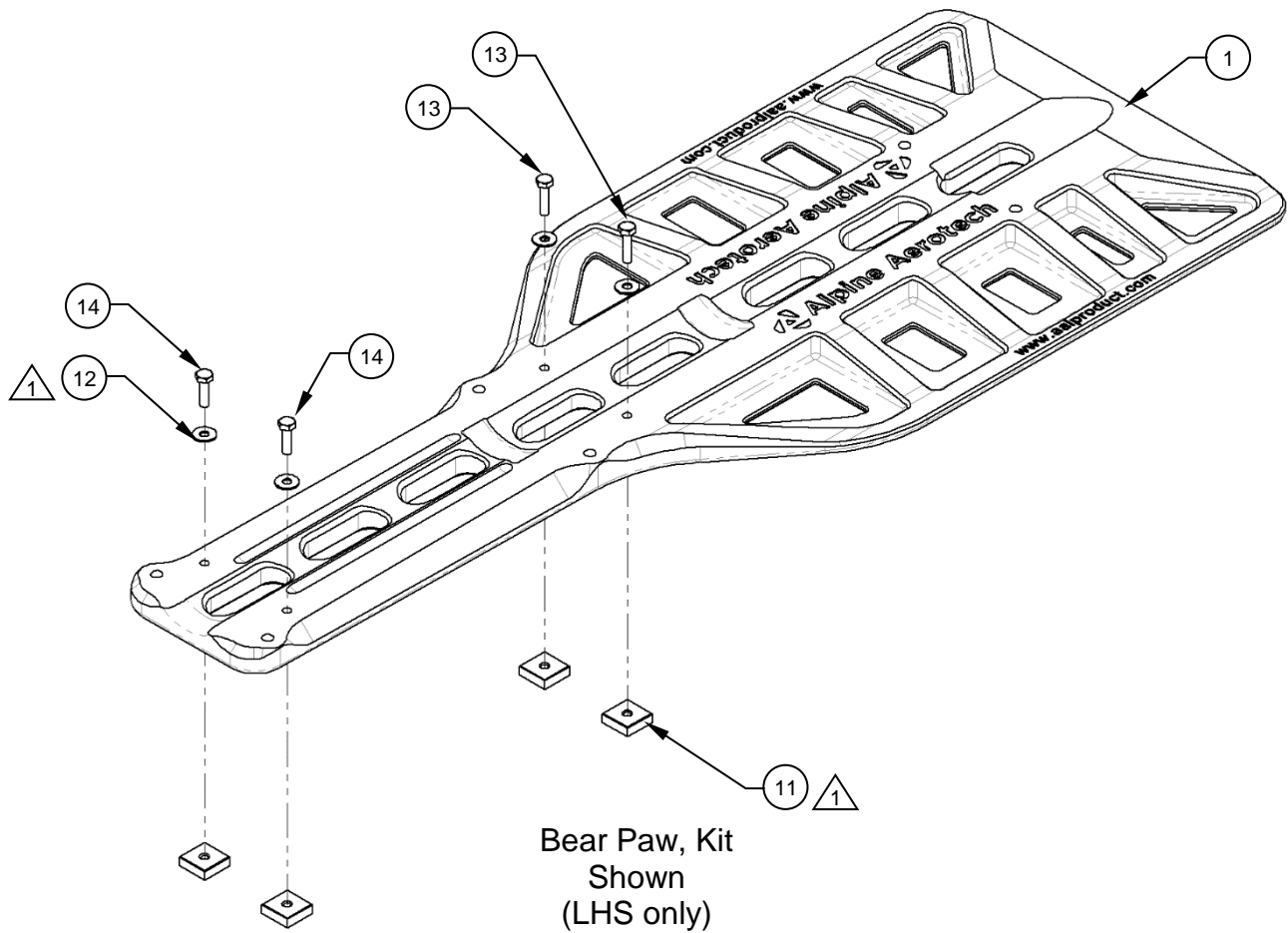

**Illustrated Parts Breakdown** (cont.)

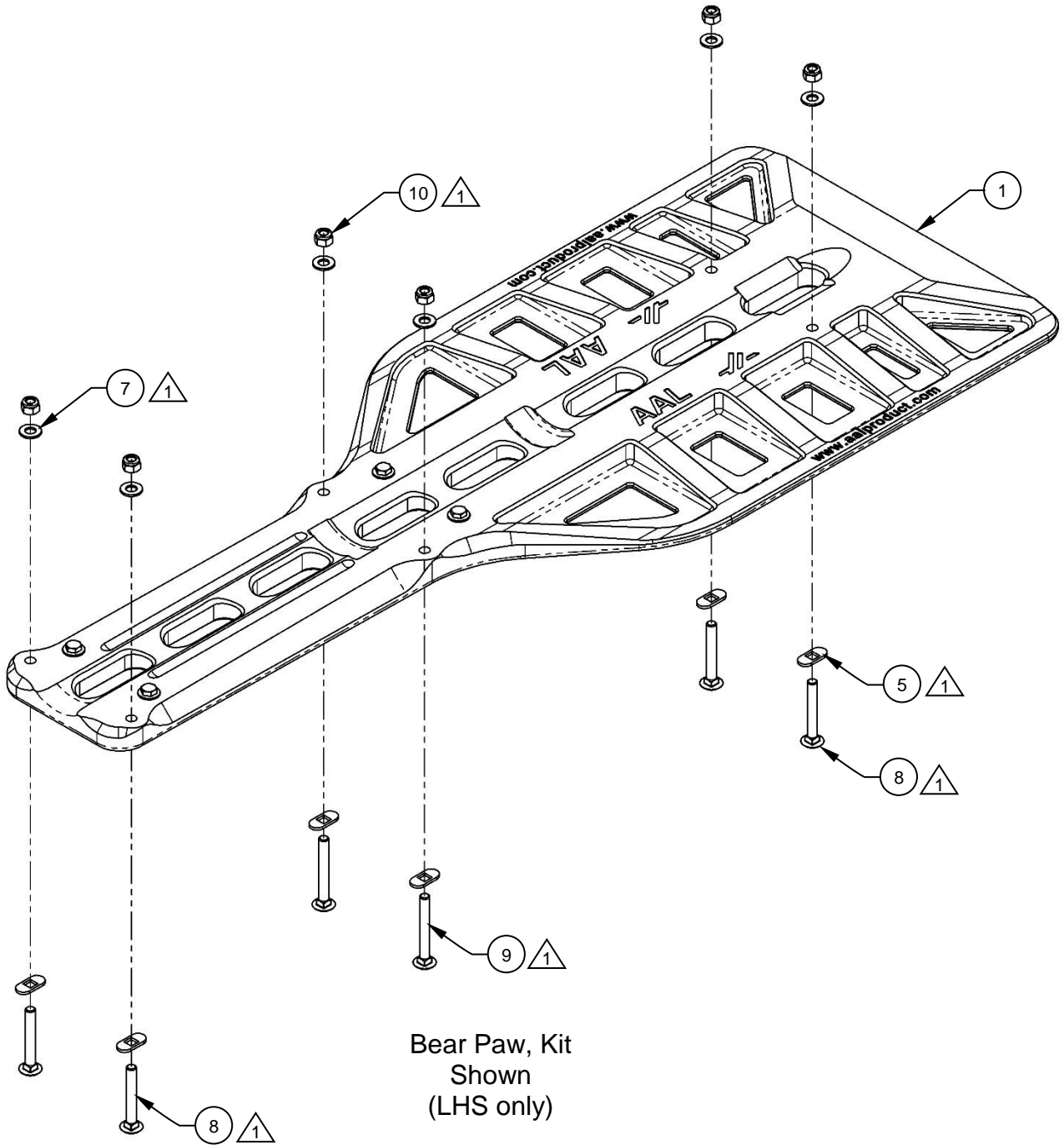

**Illustrated Parts Breakdown** (cont.)

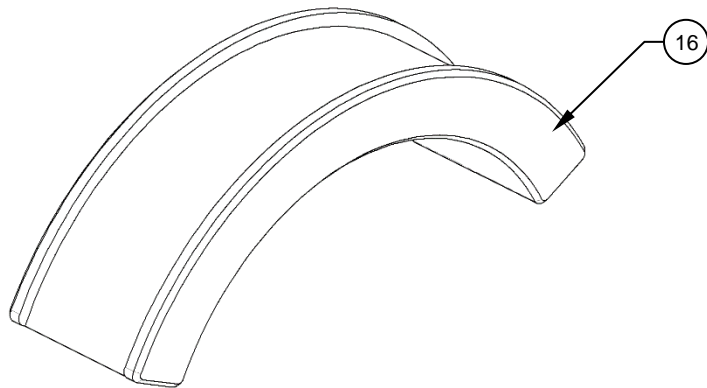
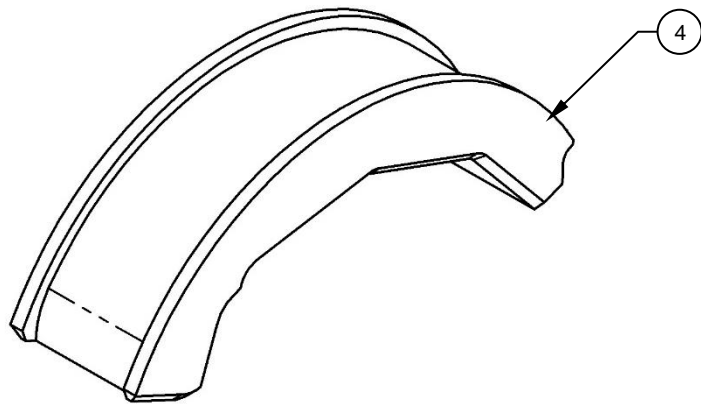
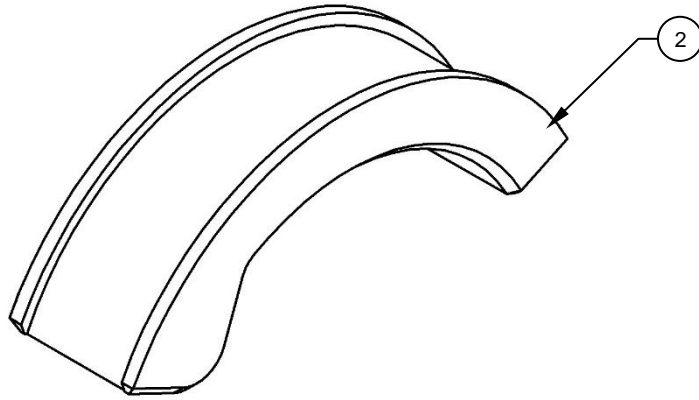

**Illustrated Parts Breakdown** (cont.)

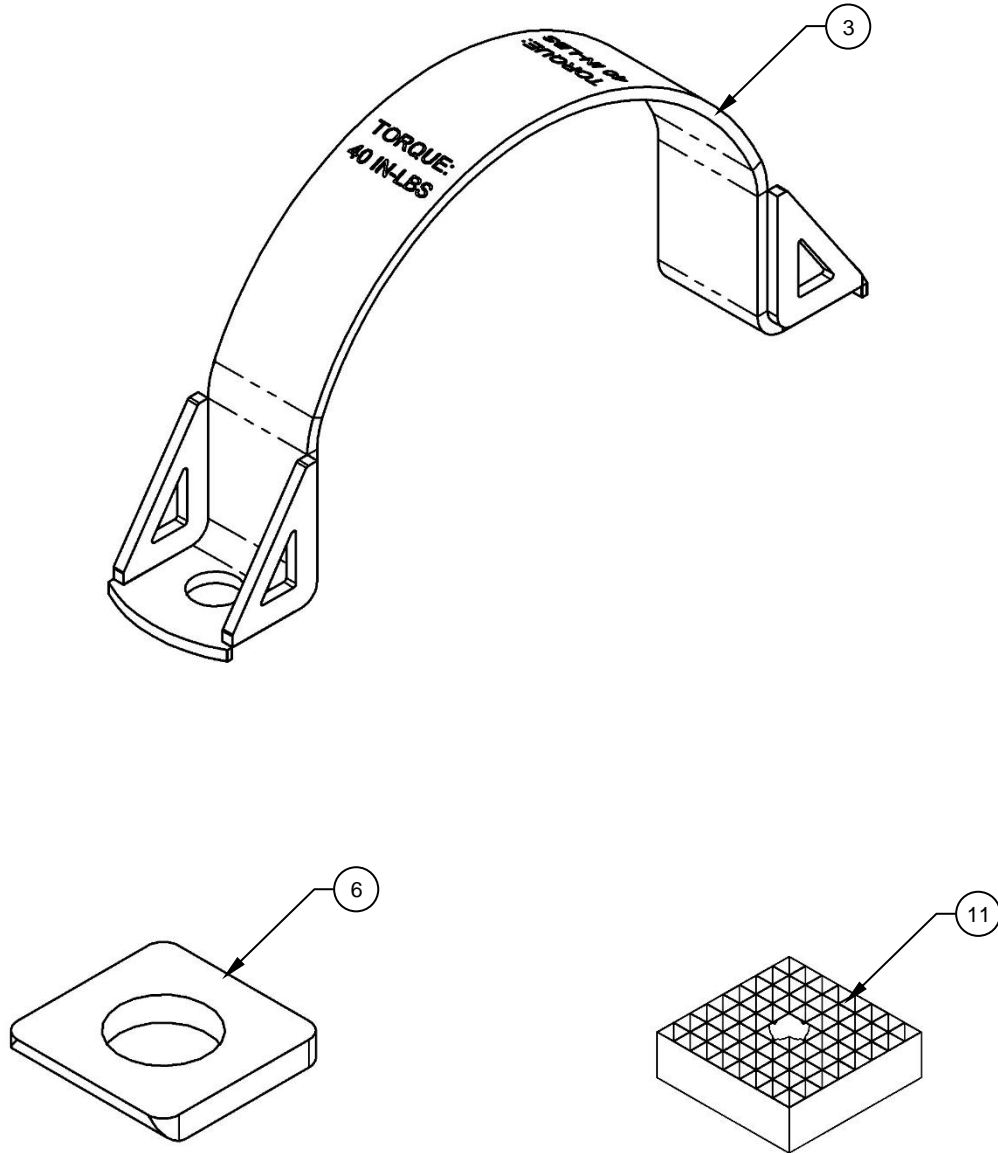

## Illustrated Parts Breakdown (cont.)

ITEM	QTY	NUMBER	DESCRIPTION	MATERIAL	REF STOCK SIZE	SPEC	FINISH	MANUFACTURER	NCAGEC
-	-	AAL-390-020-001	BEAR PAW, KIT						
1	2	AAL-390-022-001	BEAR PAW, DETAIL	NA	NA	NA	NA	ALPINE AEROTECH LP	L0171
2	4	AAL-390-022-002	CAP, DETAIL	NA	NA	NA	NA	ALPINE AEROTECH LP	L0171
3	6	AAL-390-021-001	STRAP, ASSY	NA	NA	NA	NA	ALPINE AEROTECH LP	L0171
4	2	AAL-390-022-005	CAP, DETAIL	NA	NA	NA	NA	ALPINE AEROTECH LP	L0171
5	12	AAL-290-042-006	TAB, DETAIL	NA	NA	NA	NA	ALPINE AEROTECH LP	L0171
6	12	NAS1401-5C3	WASHER, RADIUS	SEE SPEC	SEE SPEC	NAS 1401	SEE SPEC	SOURCE AS REQUIRED	NA
7	12	MS15795-812	WASHER, FLAT	SEE SPEC	SEE SPEC	NASM15795	SEE SPEC	SOURCE AS REQUIRED	NA
8	12	Ø .3125-18 x 2.250 x 2.250	BOLT, ROUND HEAD, SQUARE NECK	ASTM A307 GRADE A	SEE SPEC	ASME B18.5	ZINC PLATED	SOURCE AS REQUIRED	NA
9	4	Ø .3125-18 x 2.500 x 2.500	BOLT, ROUND HEAD, SQUARE NECK	ASTM A307 GRADE A	SEE SPEC	ASME B18.5	ZINC PLATED	SOURCE AS REQUIRED	NA
10	24	Ø .3125-18, STYLE NE	NUT, HEX, SELF-LOCKING	ASME B 18.16.6 GRADE N2	SEE SPEC	ASME B18.16.6	ZINC PLATED	SOURCE AS REQUIRED	NA
11	8	CL-16-SG	SQUARE, GRIPPER	NA	NA	NA	NA	NA	NA
12	8	MS15795-853	WASHER, FLAT	SEE SPEC	SEE SPEC	NASM15795	SEE SPEC	SOURCE AS REQUIRED	NA
13	4	AN4-10A	BOLT, MACHINE	SEE SPEC	SEE SPEC	NASM3THRU20	SEE SPEC	SOURCE AS REQUIRED	NA
14	4	AN4-7A	BOLT, MACHINE	SEE SPEC	SEE SPEC	NASM3THRU20	SEE SPEC	SOURCE AS REQUIRED	NA
2	15	AR NA	THREADLOCKER, MEDIUM STRENGTH	LOCTITE 243	SEE MFR	SEE MFR	SEE MFR	HENKEL LOCTITE CORPORATION	79436
16	6	AAL-390-022-006	CAP, DETAIL	NA	NA	NA	NA	ALPINE AEROTECH LP	L0171
2	17	AR C83317	TORQUE LACQUER	DYKEM CROSS CHECK	SEE MFR	SEE MFR	YELLOW	ITW PRO BRANDS	1QZC4