

CENTER PEDESTAL RISER, KIT INSTALLATION INSTRUCTIONS

**MODELS: BELL 205A, 205A-1, 205B, 212, 412, 412EP
&412CF**

Read all of the Instructions for Continuing Airworthiness
thoroughly prior to performing any activities relating to this product

Contents

SECTION 1 DESCRIPTION.....	3
SECTION 2 INSTALLATION & REMOVAL INSTRUCTIONS.....	4
Applicability	4
Weight & Balance	4
General Notes	5
Installation Notes.....	6
Installation Instructions	7
1. Preparing OEM Pedestal for Installation Shown.....	7
2. Perimeter Sheet Metal Initial Fitment Shown.....	9
3. Center Dzus Rail, Assy Initial Fitment Shown.....	18
4. Drilling and Riveting of the Perimeter Sheet Metal Components.....	19
5. Re-installing the OEM Defrost Fitting.....	28
6. Panel layout and installation instructions.....	31
SECTION 3 REMOVAL INSTRUCTIONS.....	42

Notes

1. If changes to this document are required, Alpine Aerotech LP shall revise all pages and reissue the entire document.
2. Alpine Aerotech LP shall make any subsequent revisions of this document available free of charge upon request. Alpine Aerotech LP also recommends that the end user of this product periodically verify the revision level of this document.
3. Rivet, Countersink/Dimple IAW MIL-STD-405. Installer may select rivet lengths longer or shorter than those shown. Rivet lengths may vary no more than two (2) dash numbers longer or shorter.

Section 1 Description

The following information provides a functional description of the Center Pedestal Riser, Kit as defined in Alpine Aerotech LP authority dataset AAL-280-090-001.

- Due to the changing requirements of operator missions there is a requirement to have an ability to mix rack mounted and panel mounted avionics in the center pedestal of Bell medium aircraft.
- When installed, the Center Pedestal Riser, Kit provides the maximum flexibility to configure the center pedestal with a mixture of rack and panel mounted devices. As well the increase in height at the AFT end of the pedestal allows for deeper instruments to be mounted further AFT if required. Lastly the change in angle reduces glare from ambient light sources allowing the flight crew to more easily read the displays.

Section 2 Installation & Removal Instructions

Applicability

The AAL Center Pedestal Riser, Kit (AAL-280-090-001) is applicable to all serial numbers of the Bell 205A, 205A-1, 205B, 212, 412, 412EP & 412CF Medium Helicopters. The maximum load of avionics allowable to be installed is 80lbs.

Weight & Balance

<u>Part Number</u>	<u>Description</u>	<u>Weight</u>	<u>Long. Arm</u>	<u>Lat. Arm</u>
AAL-280-090-001	Center Pedestal Riser, Kit	5.35* 2.43(Kg)	46.60 1.18 (m)	0.00 LBL .00 (m)

*Represents actual kit weight, not net aircraft weight change. Actual weight and balance change will have to be physically measured.

General Notes

1. All Installation Instructions shall be accomplished IAW standard aircraft practices. Refer to the current revision of the FAA Advisory Circular AC 43.13-1 and AC 43.13-2 for details on standard aircraft practices.
2. Torque fasteners IAW the tension type torque limits indicated in the current revision of the FAA Advisory Circular AC 43.13-1, Table 7-1 unless otherwise specified.
3. All Dimensions are in imperial measures (inches/pounds).
4. Refer to Section 3 through 6: Maintenance Manual Supplement in document AAL-280-095-701 Instructions for Continuing Airworthiness, for instructions on maintenance for the Item(s) referenced within this section.
5. Refer to Section 7: Illustrated Parts Breakdown in document AAL-280-095-701 Instructions for Continuing Airworthiness, for the part numbers of the Item(s) referenced within this section.
6. Ensure that OEM material mating surfaces are made bare prior to installation for proper electrical bonding per BHT-ELEC-SPM.
7. Once installation is complete conversion coat bare surfaces IAW MIL-C-5541, Class 1A, or; Conversion coat with material per QPL-81706, Class 1A or; Pre-clean with Prekote, a product of Pantheon Chemical Inc, NCAGEC 1VFJ3 (or equivalent).
8. Coat with Primer, Epoxy, High Solids per MIL-PRF-23377, Type 1 Class C2. Ensure that Dzus rails are left bare for proper electrical bonding per BHT-ELEC-SPM.
9. Coat with Paint, Polyurethane.
Color: Match OEM Pedestal color.

Definitions:

Rack mount – any component installed in the center pedestal that requires the Center Dzus Rail, Assy.

Panel mount – any component installed in the center pedestal that requires the removal of a section of the Center Dzus Rail, Assy.

Installation Notes

 Typical Item number for all like items in this view unless otherwise specified.

Installation Instructions

1. Preparing OEM Pedestal for Installation.

1.1. Gain access to the OEM pedestal. Remove and retain applicable avionics, switch control panels, and the defrost control lever. Remove and discard all avionics that will be replaced. See Figure 1.

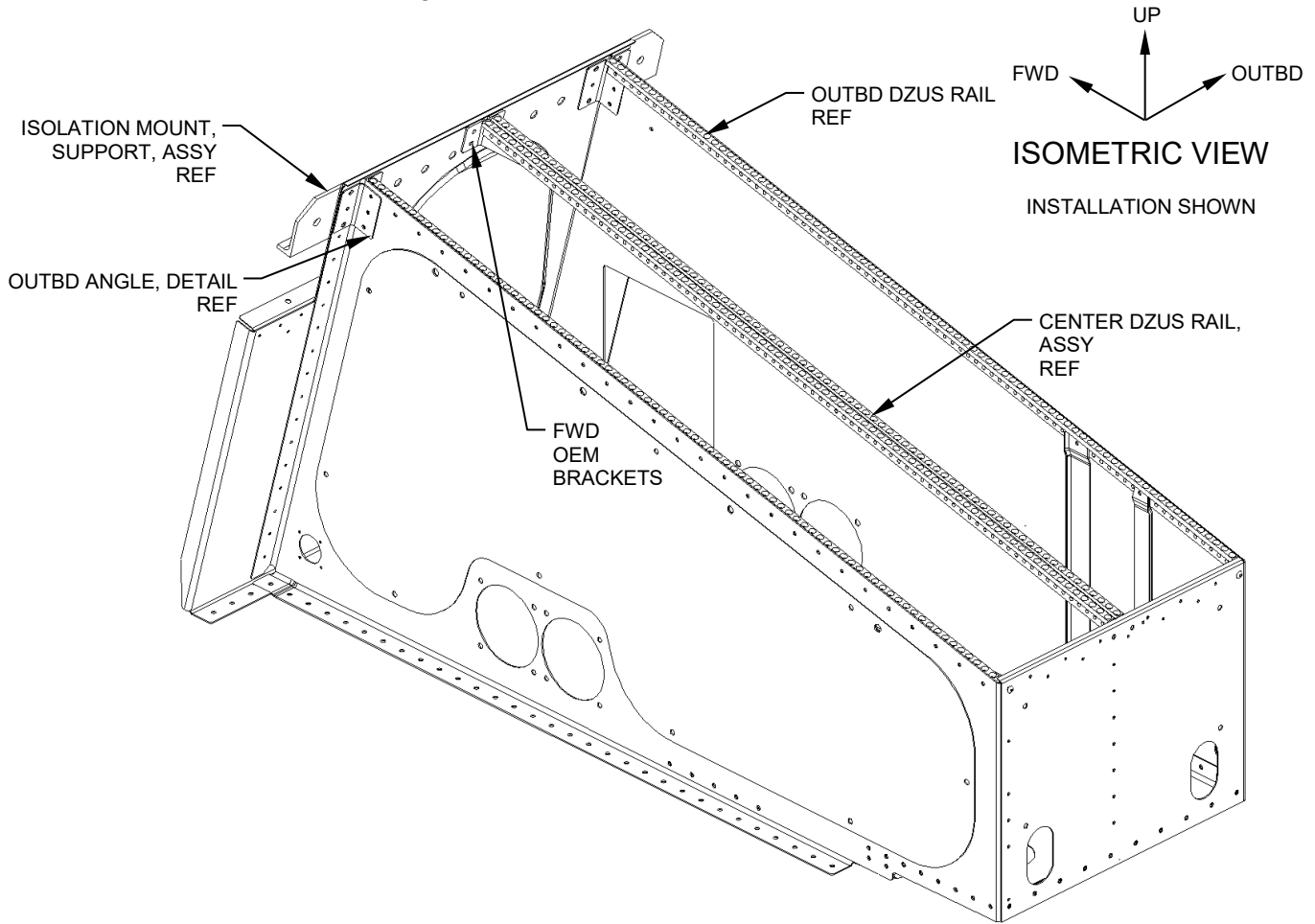

Figure 1
OEM Pedestal
Configuration
Shown

1.2. Remove and discard the LHS outboard Dzus rail. Remove and retain the RHS Dzus rail, a section is used as packing material for the OEM fittings towards the AFT end. Remove and discard the center Dzus rail assy and associated aft fittings. See Figures 1 & 2.

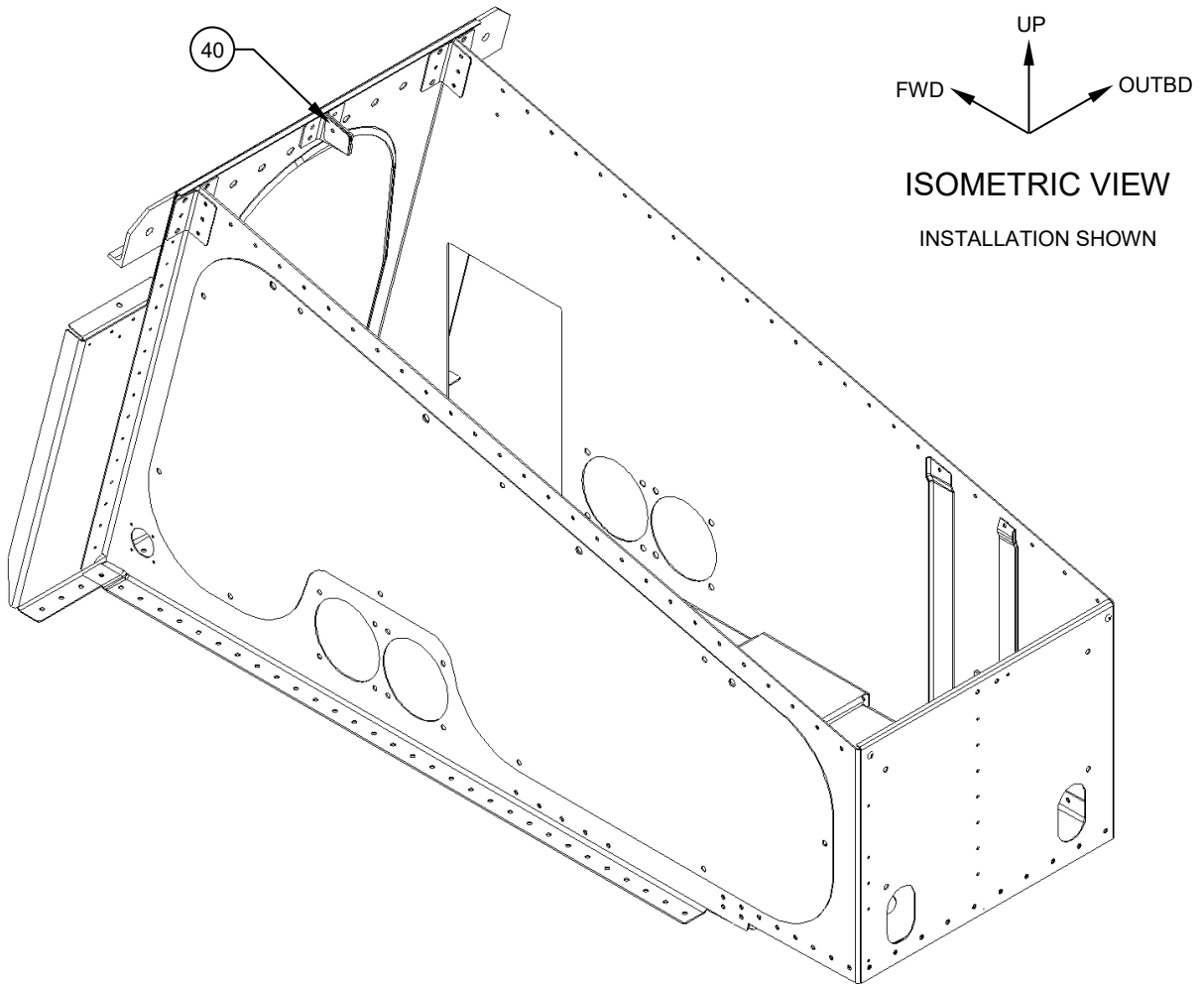

Figure 2
Prepped for Kit Installation
Shown

1.3. Temporarily install the Filler, Detail, (Item 40), with a cleco. Use the aft side of the filler part to scribe a line on the fwd OEM brackets. Trim the excess material, and remove and retain the Filler, Detail, (Item 40). See Figures 1 & 2.

1.4. Trim the OEM AFT fitting flange to be flush with the remainder of the flange. See Figures 3 & 4.

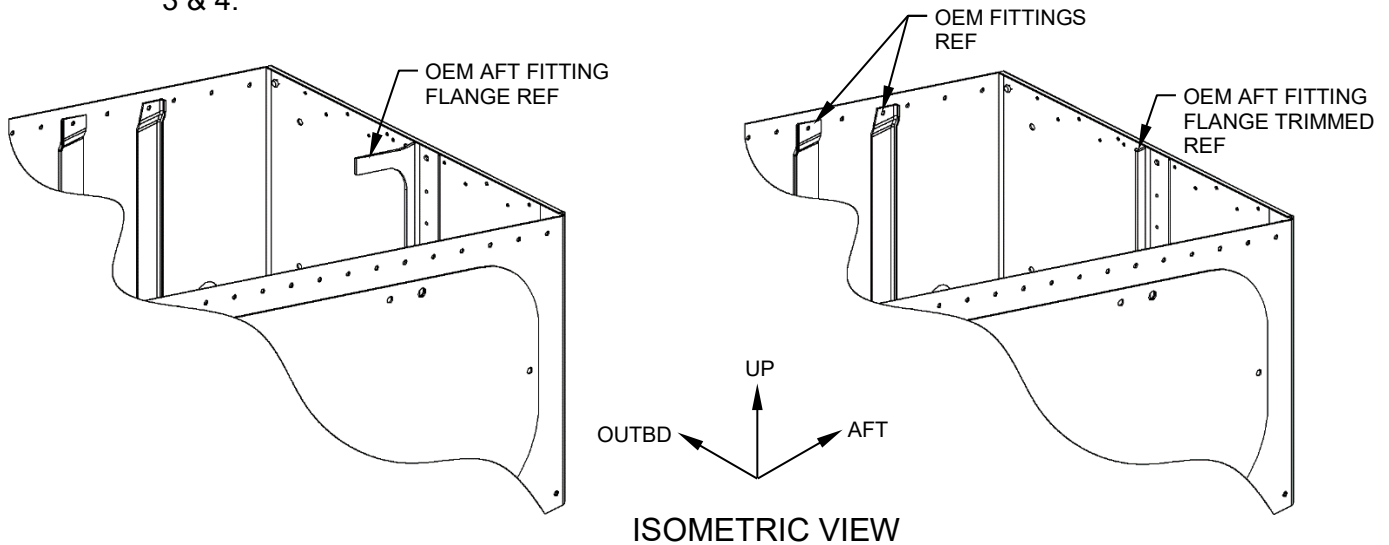

Figure 3
AFT Fitting Flange
Shown

ISOMETRIC VIEW
INSTALLATION SHOWN

Figure 4
AFT Fitting Flange
Trimmed
Shown

2. Perimeter Sheet Metal Initial Fitment.

2.1. Start with the LHS Angle, Assy, (Item 1). Using the lower edges of the Doubler, Details, (Item 3), slide the assy forward until the holes line up. See Figures 5 & 7.

2.2. Temporarily install using a cleco fastener. Transfer and drill the middle and lower fastener holes for the LHS Angle, Assy, (Item 1), final drill size #30. See Figure 8.

2.3. Transfer and drill off three equally spaced holes from the upper edge of the OEM structure to located the LHS Angle, Assy, (Item 1). Cleco fasten through the hole to position the LHS Angle, Assy, (Item 1). See Figure 5.

Note: Do not use the aft most hole.

2.4. Repeat steps 2.1, 2.2 & 2.3 for the RHS Angle, Assy, (Item 6).

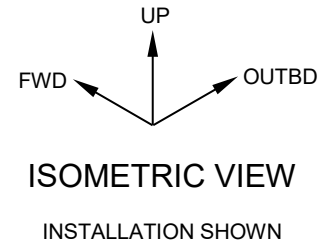
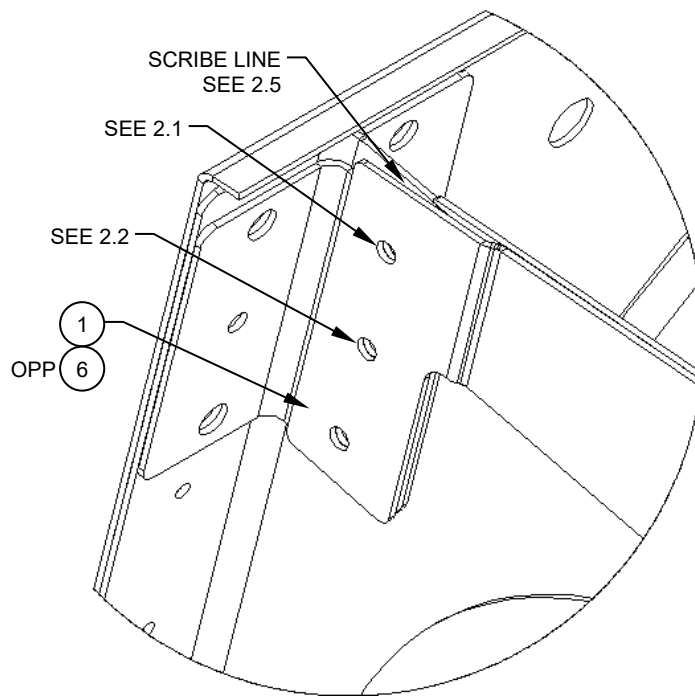

Figure 5
Removal of OEM Wall Material
LH Shown RH Opposite

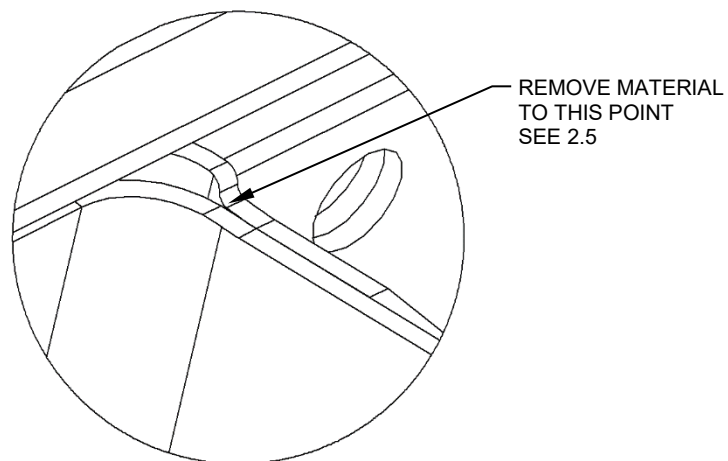
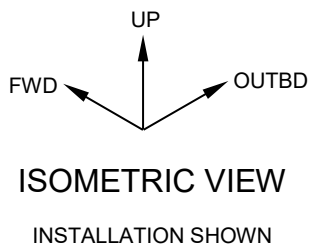

Figure 6
After Removal of OEM Wall Material
LH Shown RH Opposite

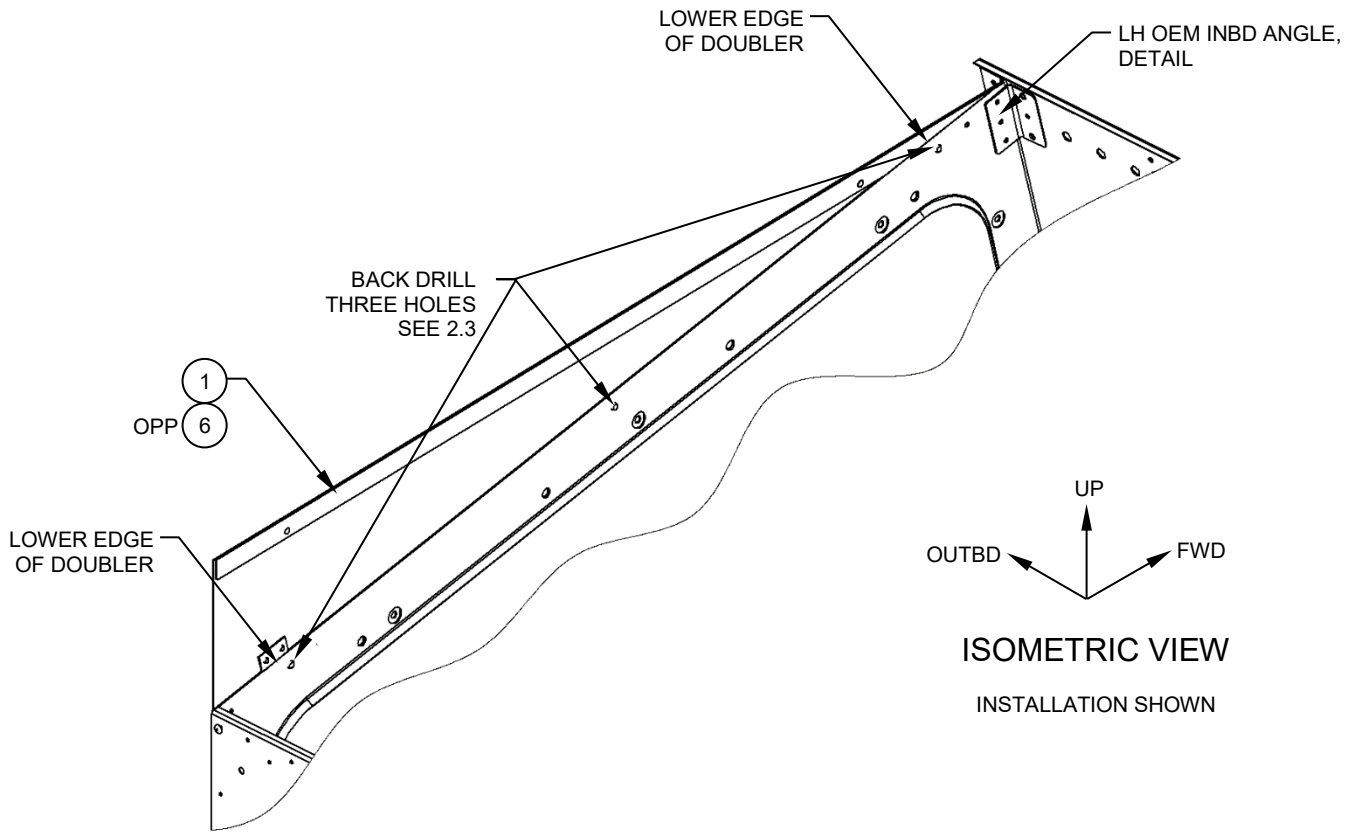

Figure 7
LHS INBD Looking OUTBD
LH Shown RH Opposite

2.5. With the LHS & RHS Angle, Assy's, (Items 1 & 6), temporarily installed, use the upper edges of the assemblies to scribe a line to trim material from the upper FWD edge of the OEM LH & RH walls, remove material until just past the radius of the flange. See Figures 5 & 6.

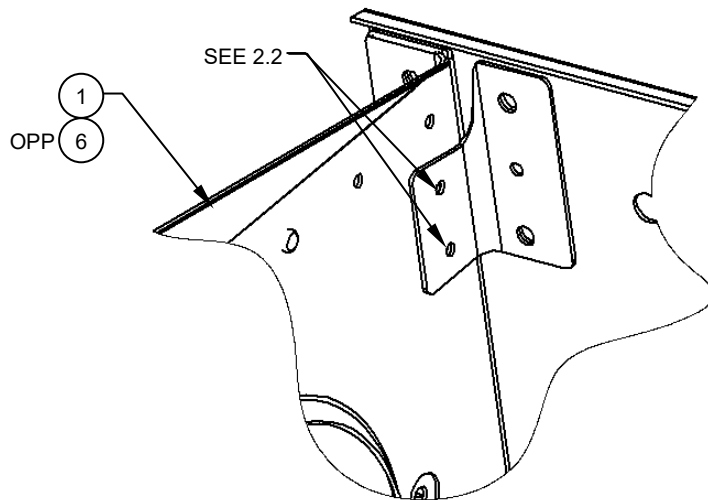
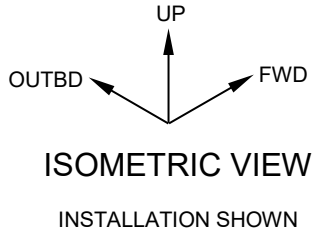
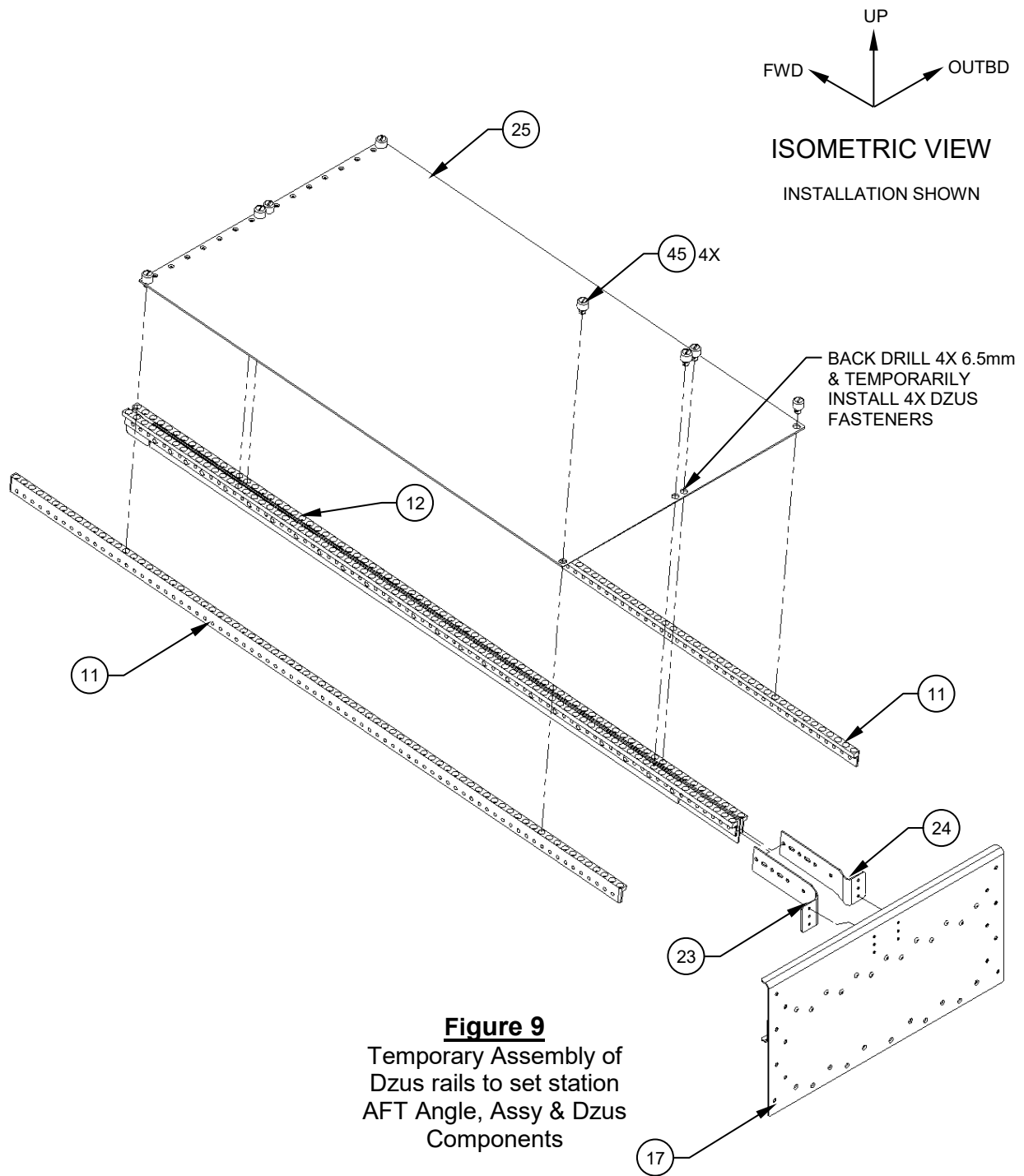

Figure 8
LHS INBD Looking OUTBD
LH Shown RH Opposite

2.6. Temporarily assemble the 1x LHS AFT Bracket, Detail, (Item 23) and the 1x RHS AFT Bracket, Detail, (Item 24), to the 1x Center Dzus Rail, Assy, (Item 12). See Figure 9.



- 2.7. Align the LHS and RHS Dzus Rail, Details, (Item 11), to the Center Dzus Rail, Assy, (Item 12), in station. Temporarily assemble 2x Dzus Rail, Detail (Item 11), 1x Center Dzus Rail, Assy (Item 12), to the Panel Mount Plate, Assy, (Item 25), using the attached Fastener Panel, Stud, ¼ Turn, along the top edge. Using 4x of the loose Fastener Panel, Stud, ¼ Turn, (Item 45), along the bottom edge holes. **Note:** Do not permanently install the loose fasteners at this time. See Figure 9.
- 2.8. Temporarily assemble with cleco's, the Aft, Angle, Assy, (Item 17), to the, 1x AFT LHS Bracket, Detail, (Item 23) and the 1x RHS AFT Bracket, Detail, (Item 24). See Figure 9.
- 2.9. Install this temporary assembly with cleco's between the LHS & RHS Angle, Assy's, (Items 1 & 6). Adjust the position in station until the FWD holes on the Dzus Rail, Details, (Items 11), line up with the FWD hole on the OEM structure. See Figure 10.

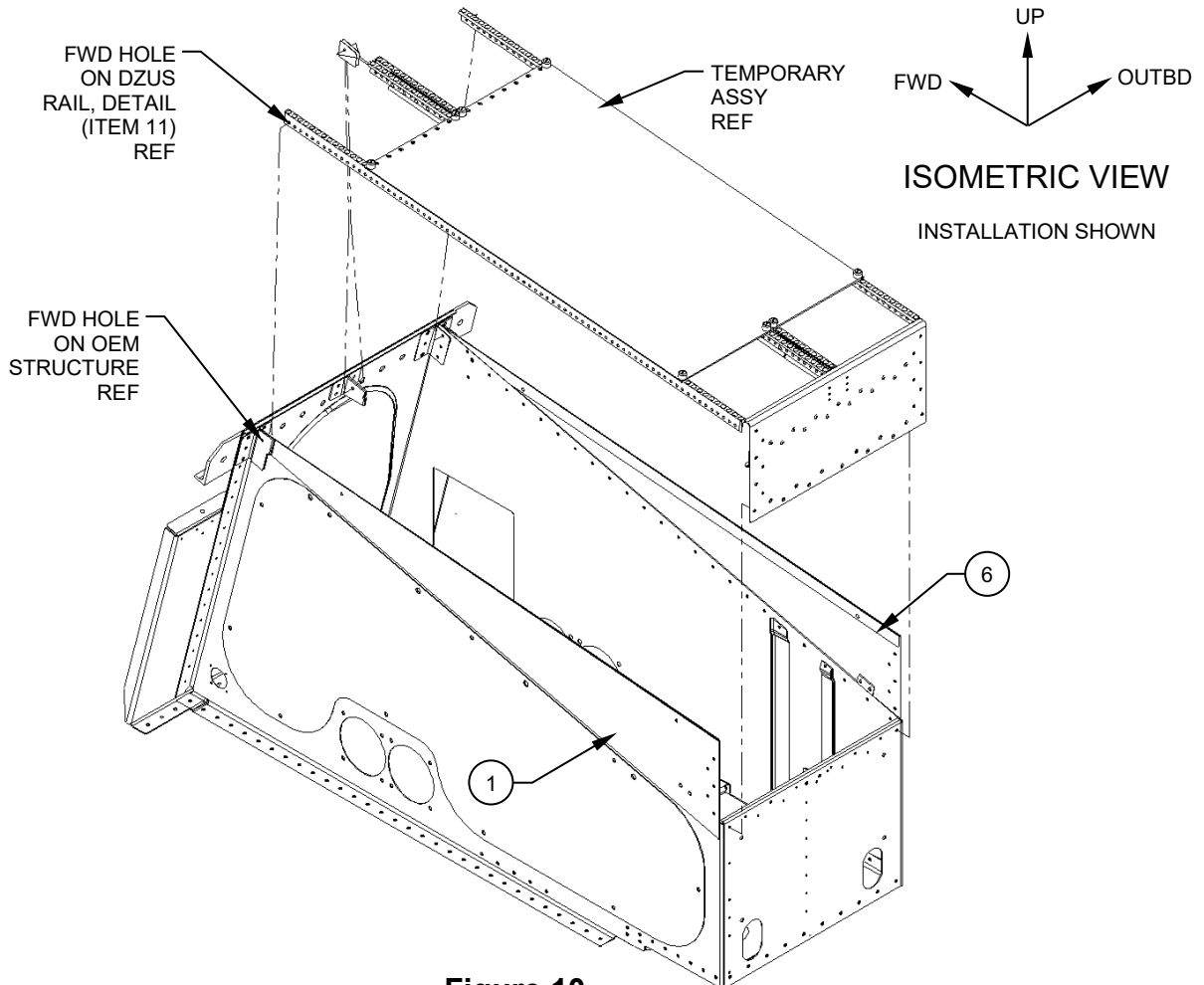

Figure 10
Positioning of Items 11, 12, 17 & 23 thru 26

- 2.10. Transfer & drill for 2x Rivet, Solid, Universal Head, (Item 31). **Note:** The rivet pattern for the top edge, is every fourth hole, except for the aft most rivet, which is a five-hole spacing. Temporarily install cleco's in these two positions. See Figure 10.
- 2.11. Using the slotted holes in the LHS/RHS AFT Bracket, Details, (Items 23 & 24), adjust the position of the Aft Angle, Assy, (Item 17) so it is parallel to the OEM wall. See figure 11.

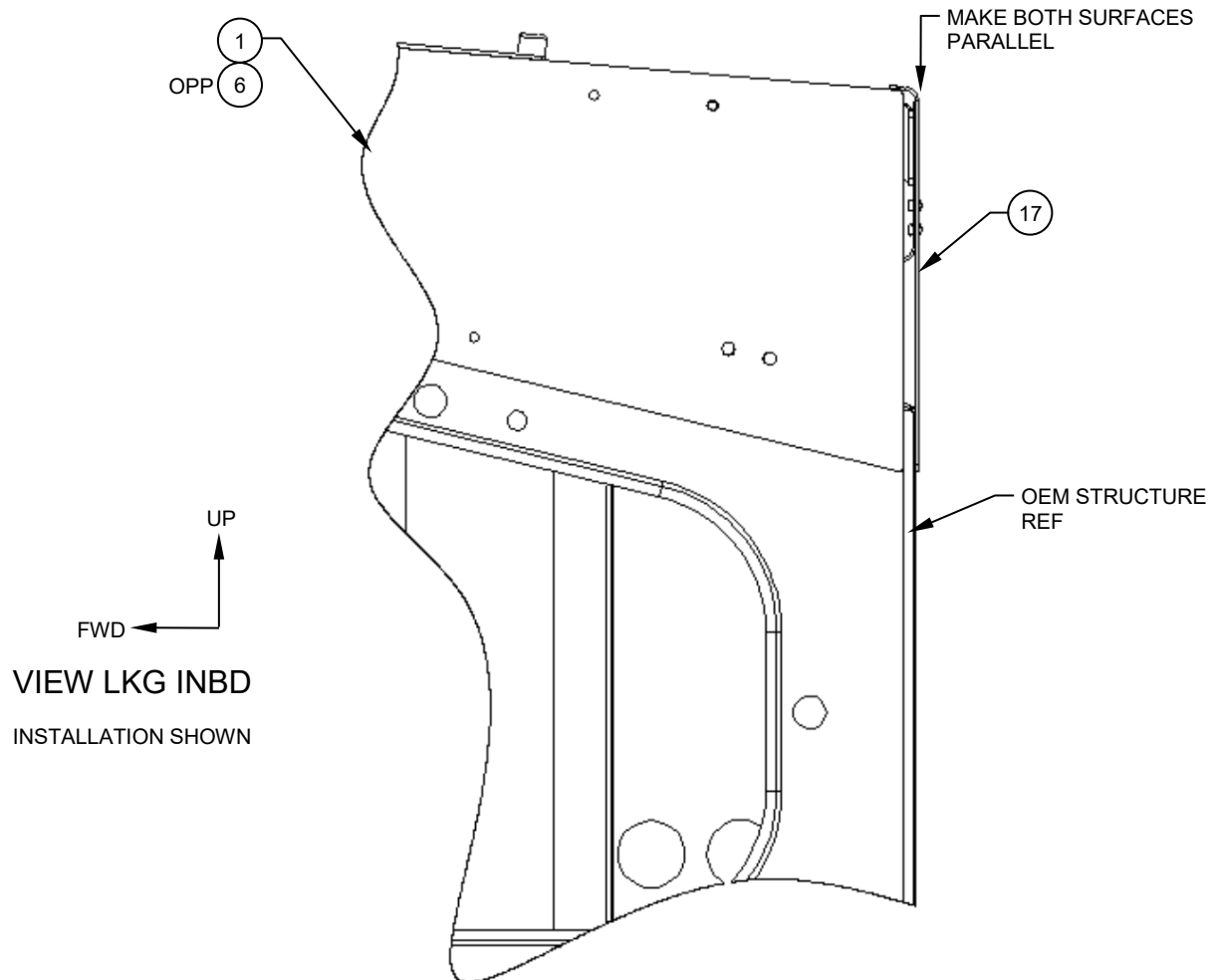
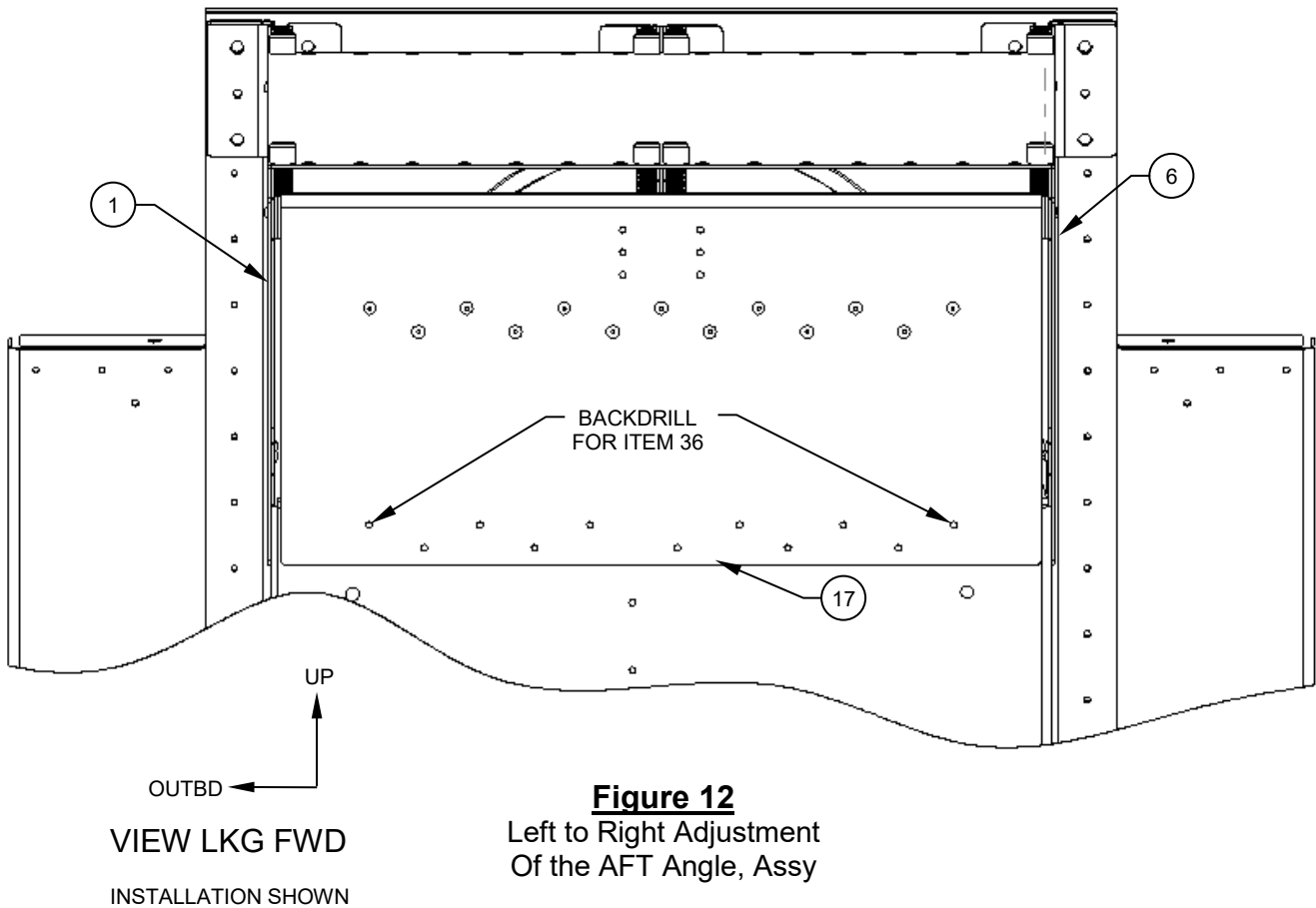

Figure 11
Adjustment of the
AFT Angle, Assy
Shown
Some Items Not Shown
For Clarity

2.12. Ensure that the LHS/RHS Angle, Assy's, (Items 1 & 6), are as close to vertical and symmetric, as possible. Transfer and drill thru for 2x Rivet, Solid, Universal Head, (Item 36), equally spaced on either side of BL and cleco in place. See figure 12.



2.13. Fit the LHS/RHS AFT Angle, Details, (Items 21 & 22), so that the outboard lower edges match up with the lower edges of the LHS/RHS Angle, Assy's, (Items 1 & 6). See figure 13.

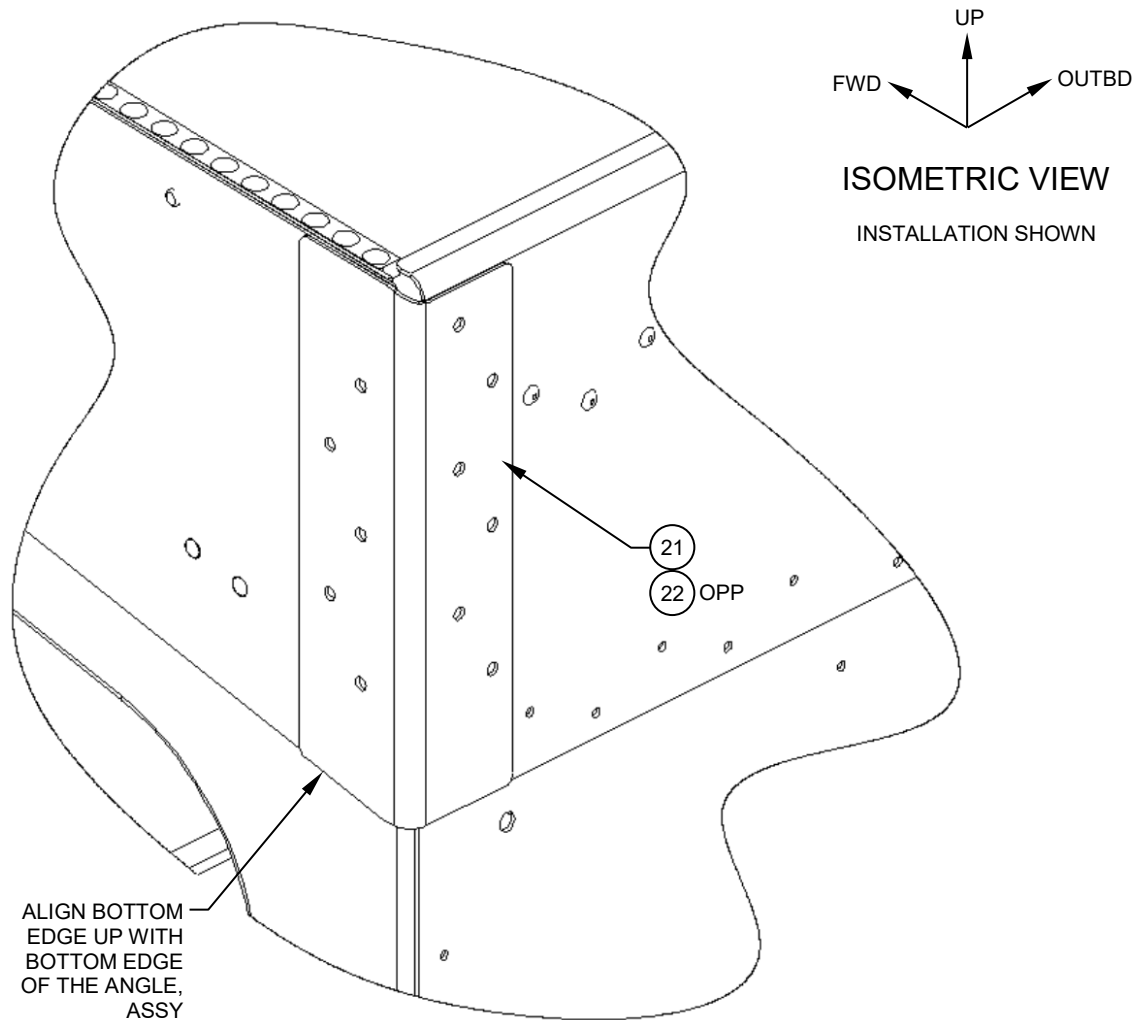

Figure 13
LHS Installation Shown
RHS Opposite

2.14. Transfer and drill 2x per face for -4 (#30 Drill), temporarily install using cleco's.

3. Center Dzus Rail, Assy Initial Fitment Shown.

3.1. Align the 2X Filler, Detail, (Item 40), with the previously trimmed edge, and 1X Drill through the Center Dzus Rail, Assy, (Item 12), 2X Filler, Detail, (Item 41), and the OEM stucture, for 2x Rivet, Solid, Universal Head, (Item 37). See Figure 14.

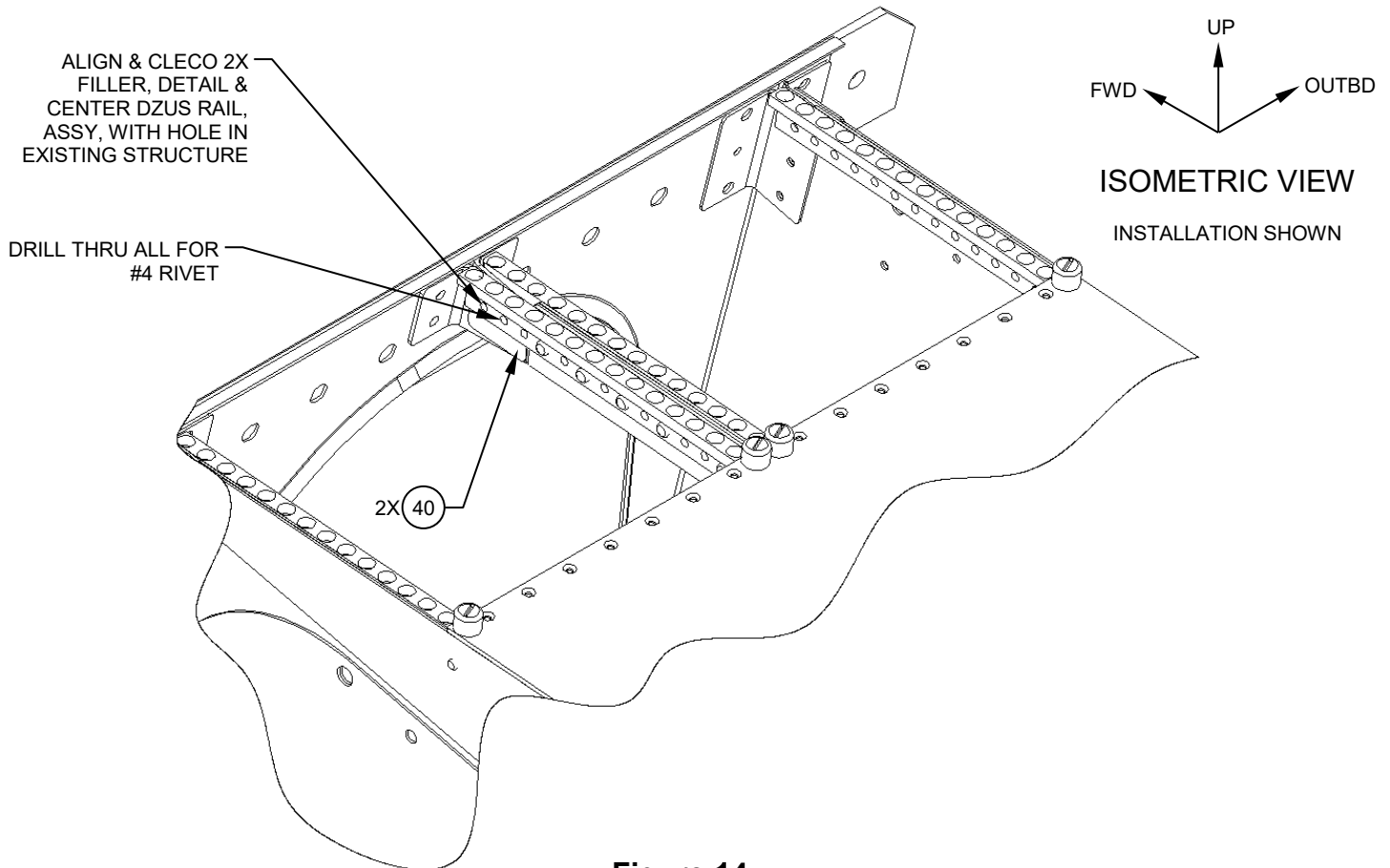

Figure 14
Fitment of Filler, Details, (Items 41)
To OEM Structure and Installation to
Center Dzus Rail, Assy (Item 12)
Shown

3.2. Detach the Temporary assy from the LHS/RHS Dzus Rail, Detail, (Item 11), remove and retain the components of the temporary assy. See figures 10 & 15.

3.3. Fitting of the perimeter sheet metal components is now complete. Perform a thorough inspection to determine that all components are ready for the next stage. See figure 15.

4. Drilling and Riveting of the Perimeter Sheet Metal Components.

4.1. Starting on the LHS. Back-drill from OEM structure thru the LHS Angle, Assy, (Item 1), for 2x Rivet, Solid, Universal Head, (Item 34), and 24x Rivet, Solid, Universal Head, (Item 32), stopping three instances from the FWD end. See Figure 15.

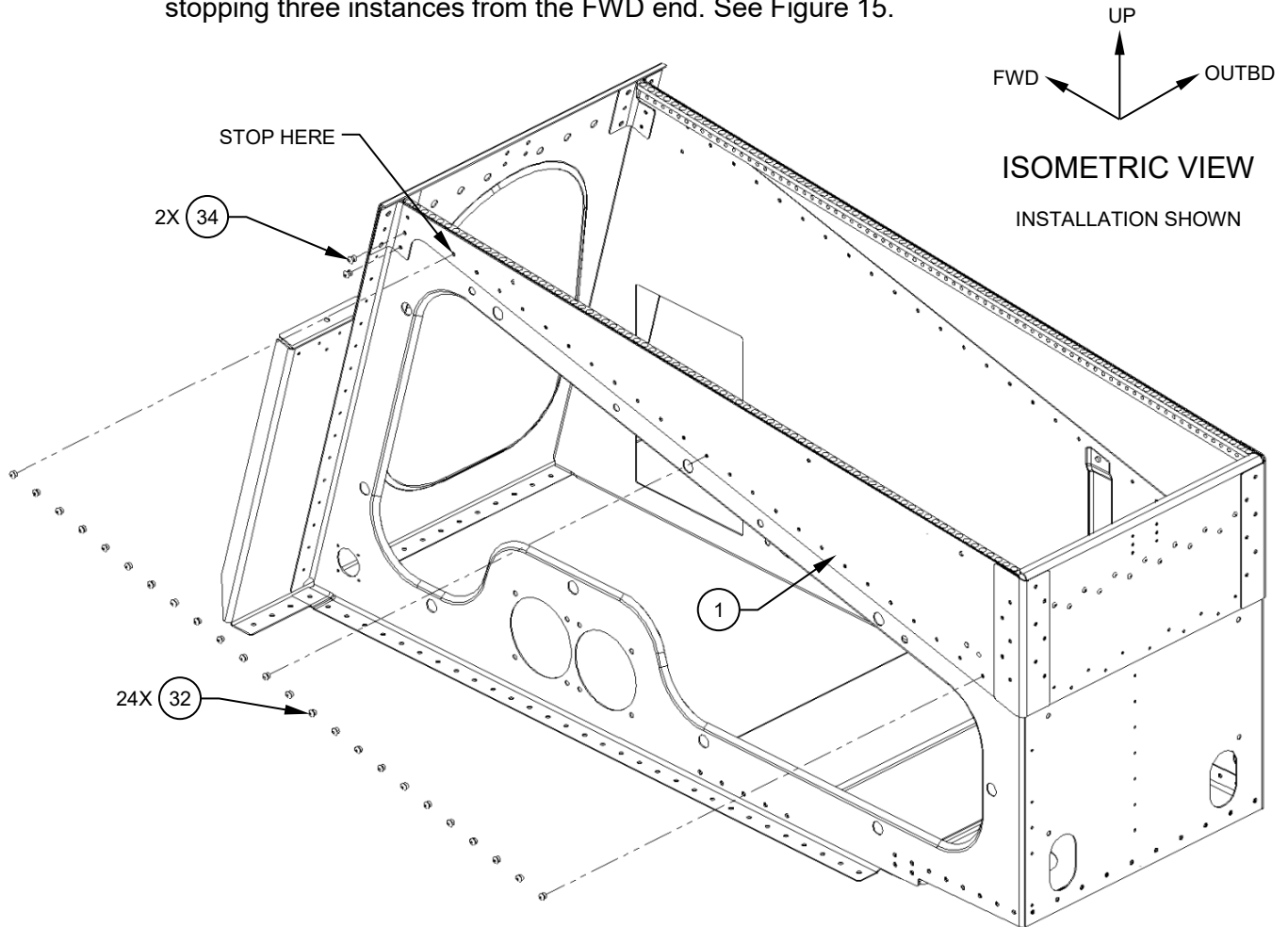

Figure 15

4.2. Back-drill from Dzus Rail, Detail, (Item 11), thru the LHS Angle, Assy, (Item 1), for 25x Rivet, Solid, Universal Head, (Item 31). Starting at the FWD most hole used to locate the Dzus Rail, Detail, (Item 11) in station. The pattern is as follows, rivet one, skip two, rivet one. See Figure 16.

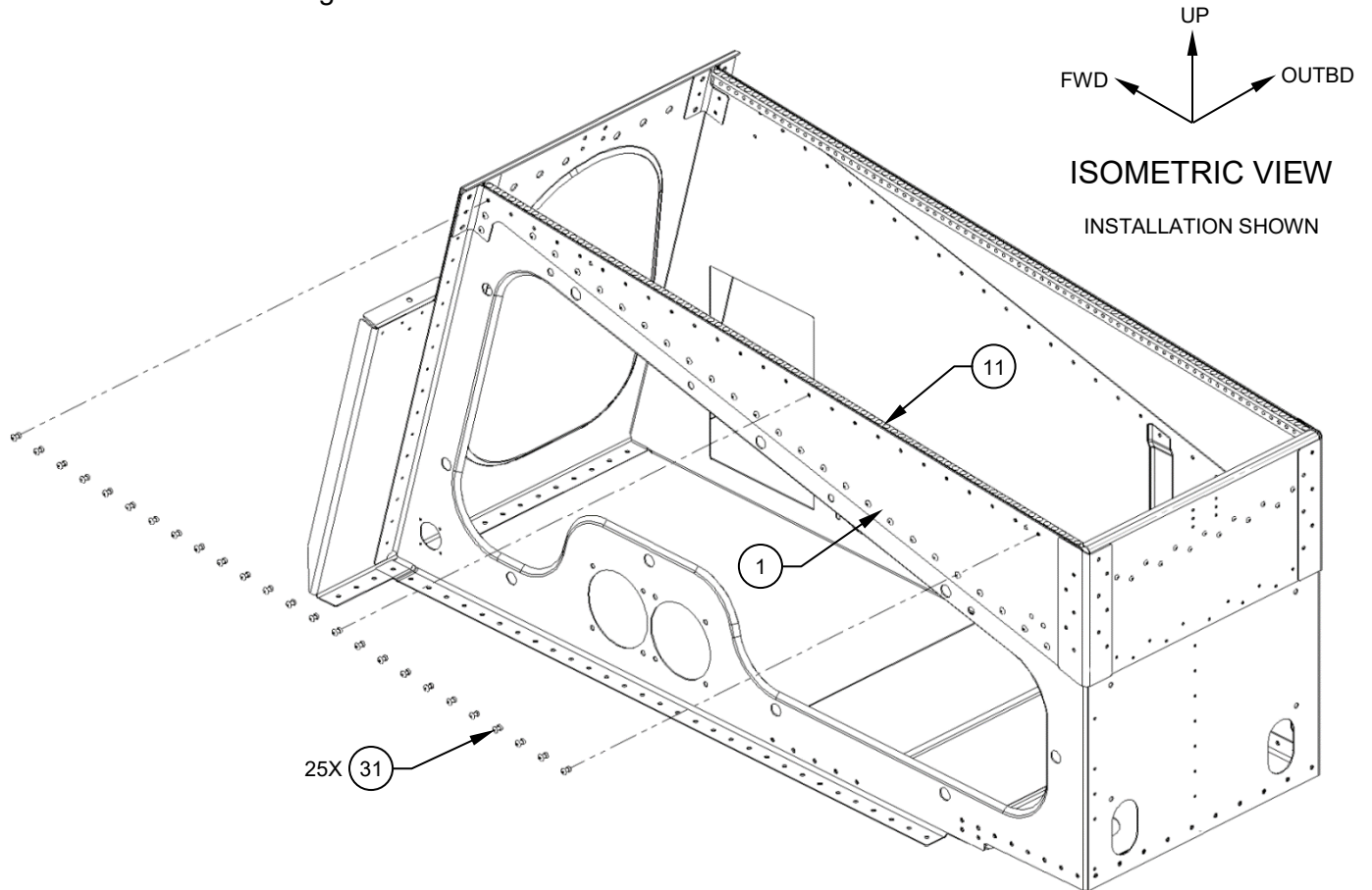

Figure 16

- 4.3. For the upper OUTBD rivet hole on the LHS Angle, Detail, (Item 21), skip the first hole and drill the second hole, on the Dzus Rail, Detail, (Item 11), and back drill from the fourth hole on the Dzus Rail, Detail, (Item 11), through the LHS Angle, Assy, (Item 1), LHS Angle, Detail, (Item 21), then 1x Rivet, Solid, Universal Head, (Item 30). See Figure 17.
- 4.4. For the lower OUTBD rivet hole on the LHS Angle, Detail, (Item 21), back drill from the aft most OEM rivet location, through the LHS Angle, Assy, (Item 1), LHS Angle, Detail, (Item 21), then 1x Rivet, Solid, Universal Head, (Item 33). See Figure 17.
- 4.5. For the remaining five locations drill through existing holes in the LHS Angle, Detail, (Item 21), through the LHS Angle, Assy, (Item 1), and 5x Rivet, Solid, Universal Head, (Item 32). See Figure 17.

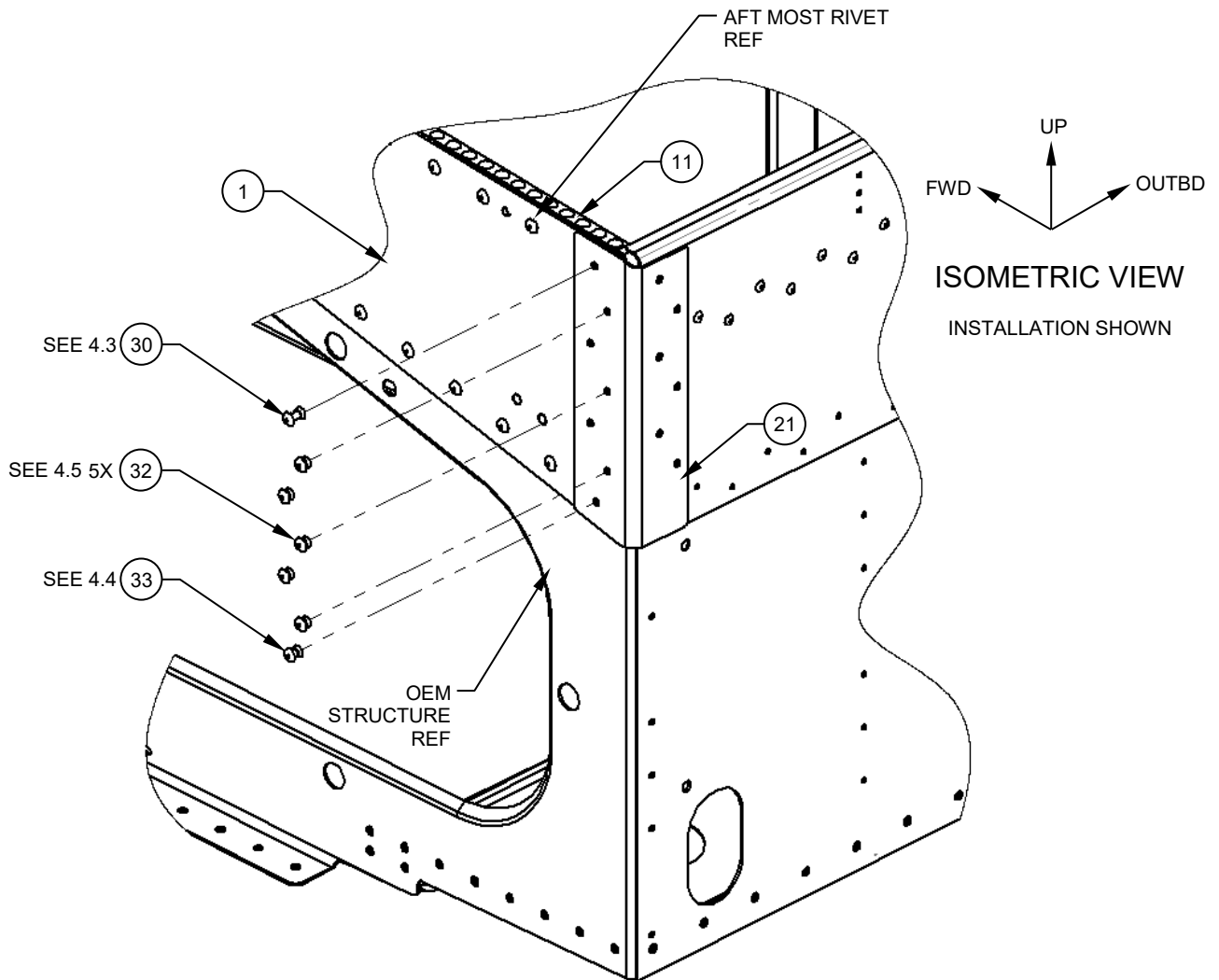

Figure 17

4.6. Starting on the RHS. Using the OEM RHS Dzus Rail, trim as shown for packing purposes on the two inbd fittings. Drill through from the INBD side 2x Rivet, Solid, Universal Head, (Item 30), and 1x Rivet, Solid, Universal Head, (Item 31). See Figure 18.

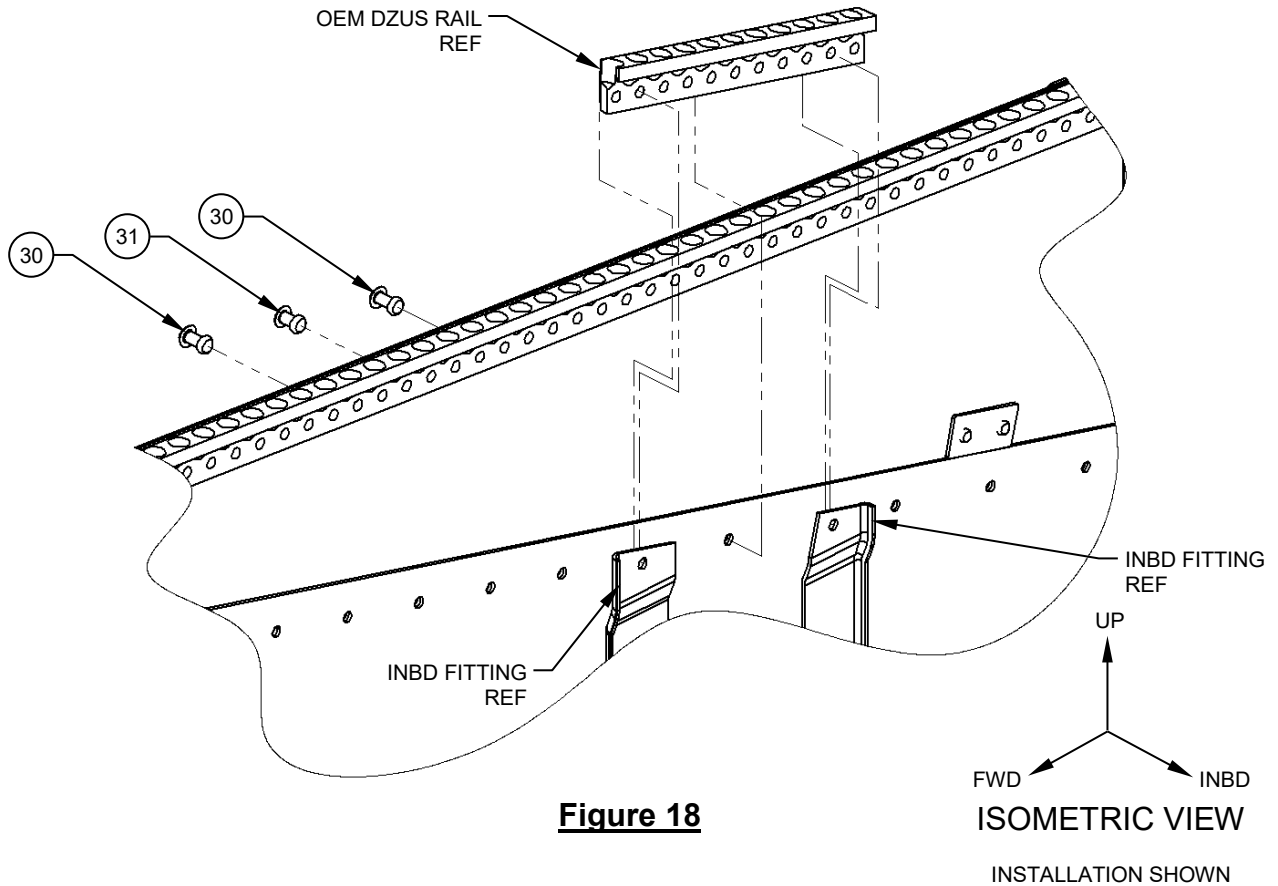

Figure 18

4.7. Back-drill from OEM structure thru the RHS Angle, Assy, (Item 6), for 2x Rivet, Solid, Universal Head, (Item 33), and 18x Rivet, Solid, Universal Head, (Item 32). Stop just before the jog down in the sheet metal. See Figure 19.

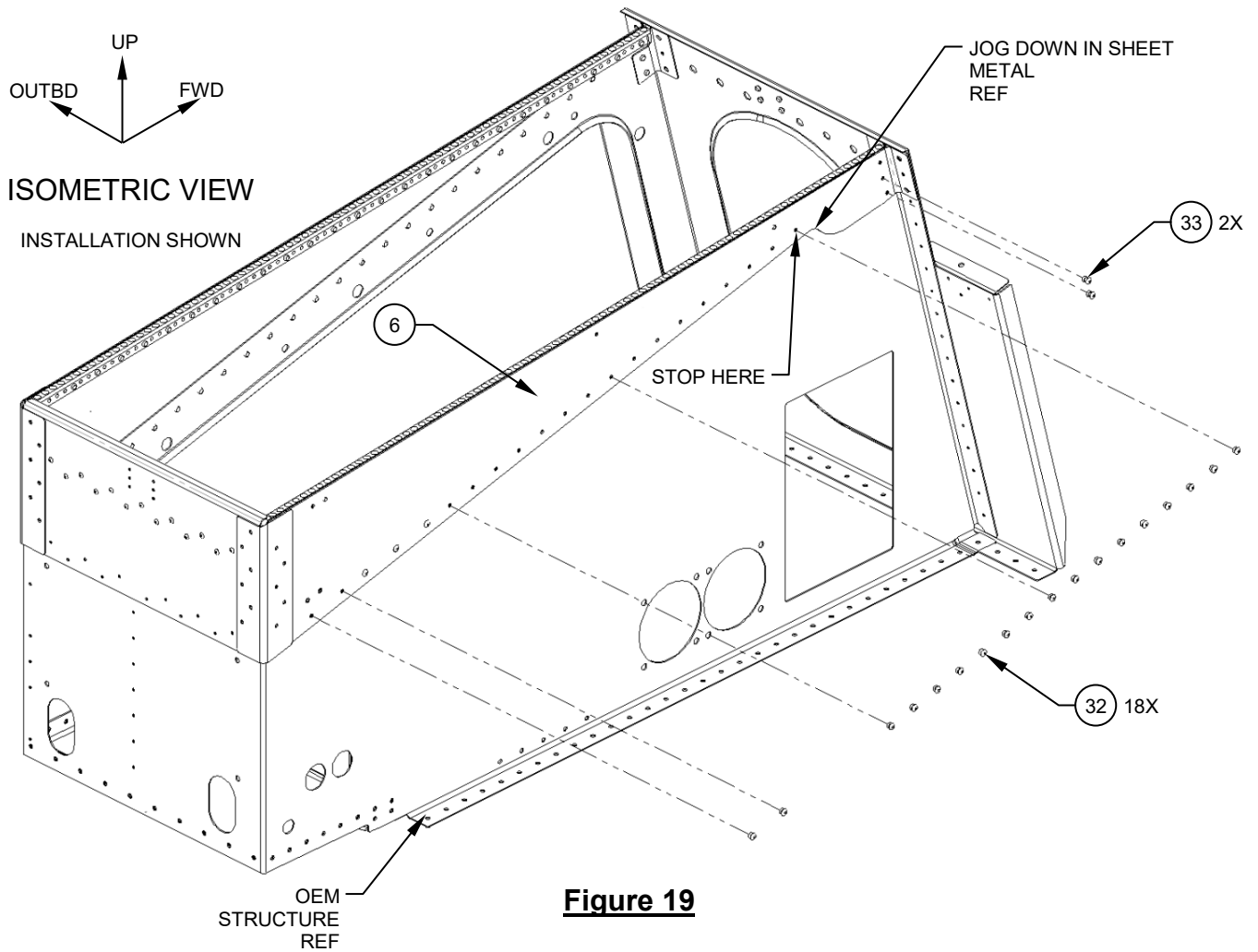
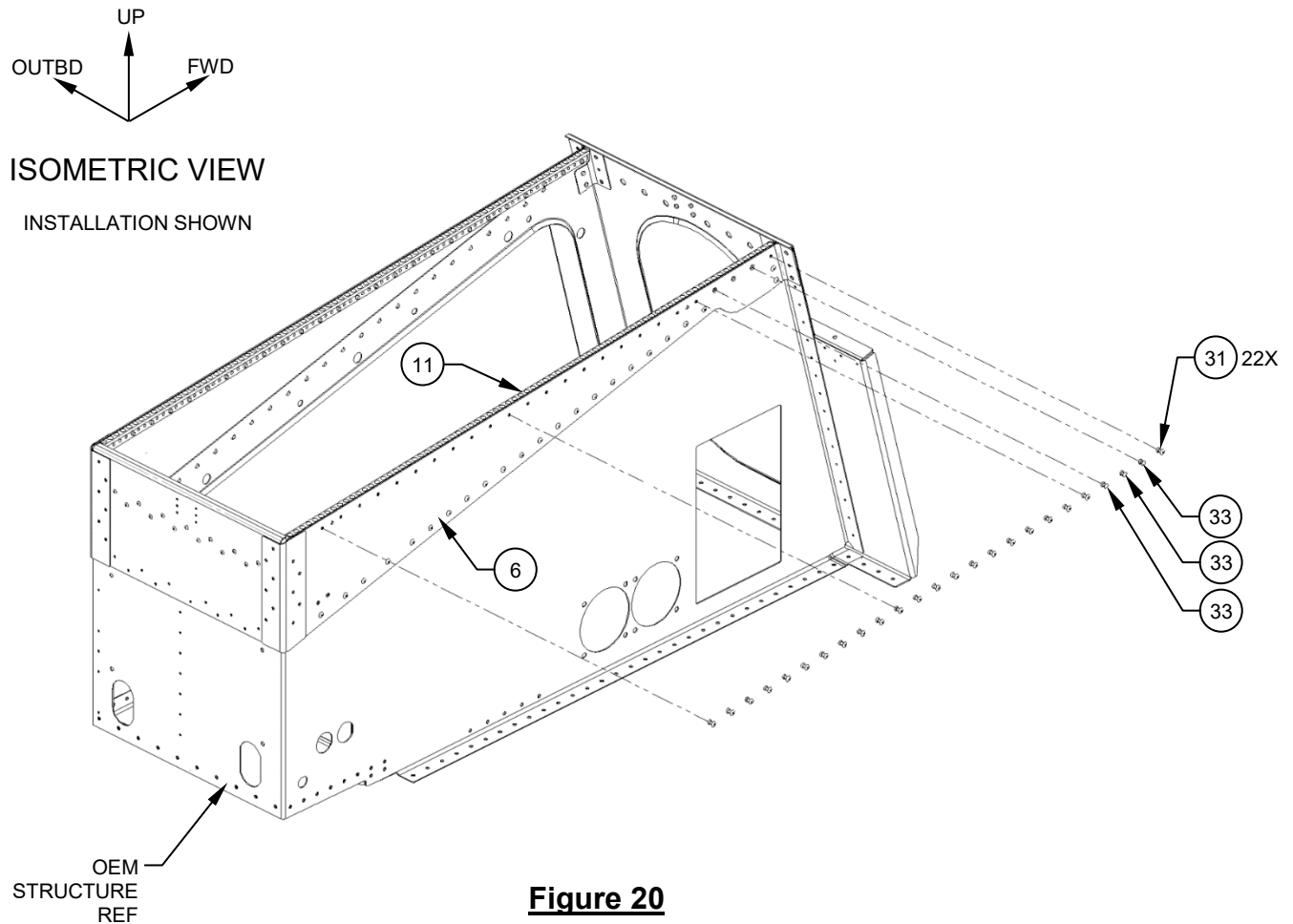

Figure 19

4.8. Back-drill from Dzus Rail, Detail, (Item 11), thru the RHS Angle, Assy, (Item 6), for 25x -4 Rivets, with a #30 drill. Start at the FWD most hole used to locate the Dzus Rail, Detail, (Item 11) in station. The pattern is as follows, drill one, skip two, drill one. For the second, third and fourth instances from the FWD end, countersink for, 3x Rivet, Solid, Countersunk Head, (Item 33). For the first, and fifth thru 25 instances, install 22x Rivet, Solid, Universal Head, (Item 31). See Figure 20.



- 4.9. For the upper OUTBD rivet hole on the RHS Angle, Detail, (Item 22), skip the first hole and drill the second hole, on the Dzus Rail, Detail, (Item 11), and back drill from the fourth hole on the Dzus Rail, Detail, (Item 11), through the RHS Angle, Assy, (Item 6), RHS Angle, Detail, (Item 22), then 1x Rivet, Solid, Universal Head, (Item 30). See Figure 21.

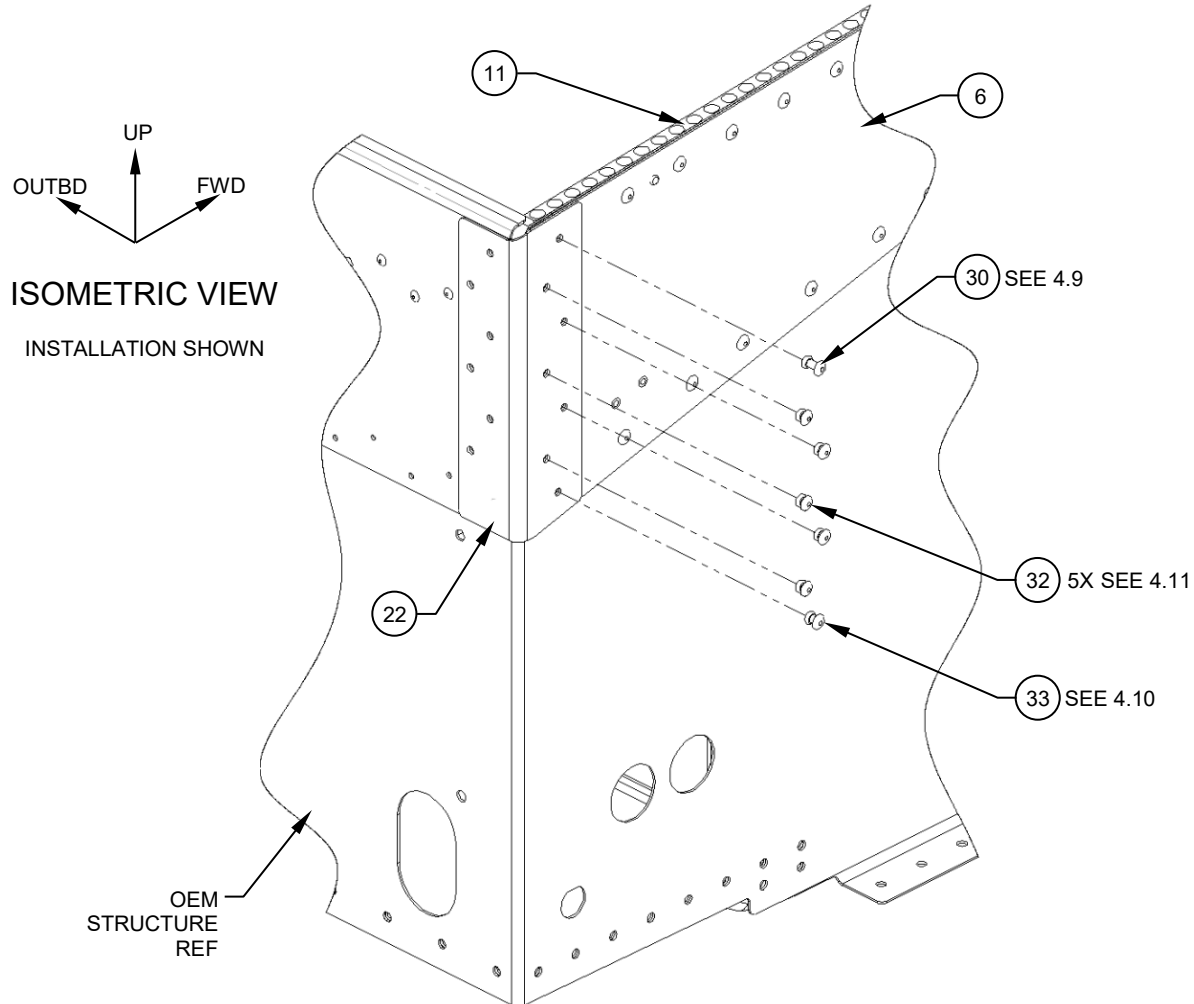

Figure 21

- 4.10. For the lower OUTBD rivet hole on the RHS Angle, Detail, (Item 22), back drill from the aft most OEM rivet location, through the RHS Angle, Assy, (Item 6), RHS Angle, Detail, (Item 22), then 1x Rivet, Solid, Universal Head, (Item 33). See Figure 21.
- 4.11. For the remaining five locations drill through existing holes in the RHS Angle, Detail, (Item 22), through the RHS Angle, Assy, (Item 6), and 5x Rivet, Solid, Universal Head, (Item 32). See Figure 21.

4.12. Back drill for 11x Rivet, Solid, Universal Head, (Item 36), from 1x AFT Angle, Assy, (Item 17) thru the OEM structure. See Figure 22.

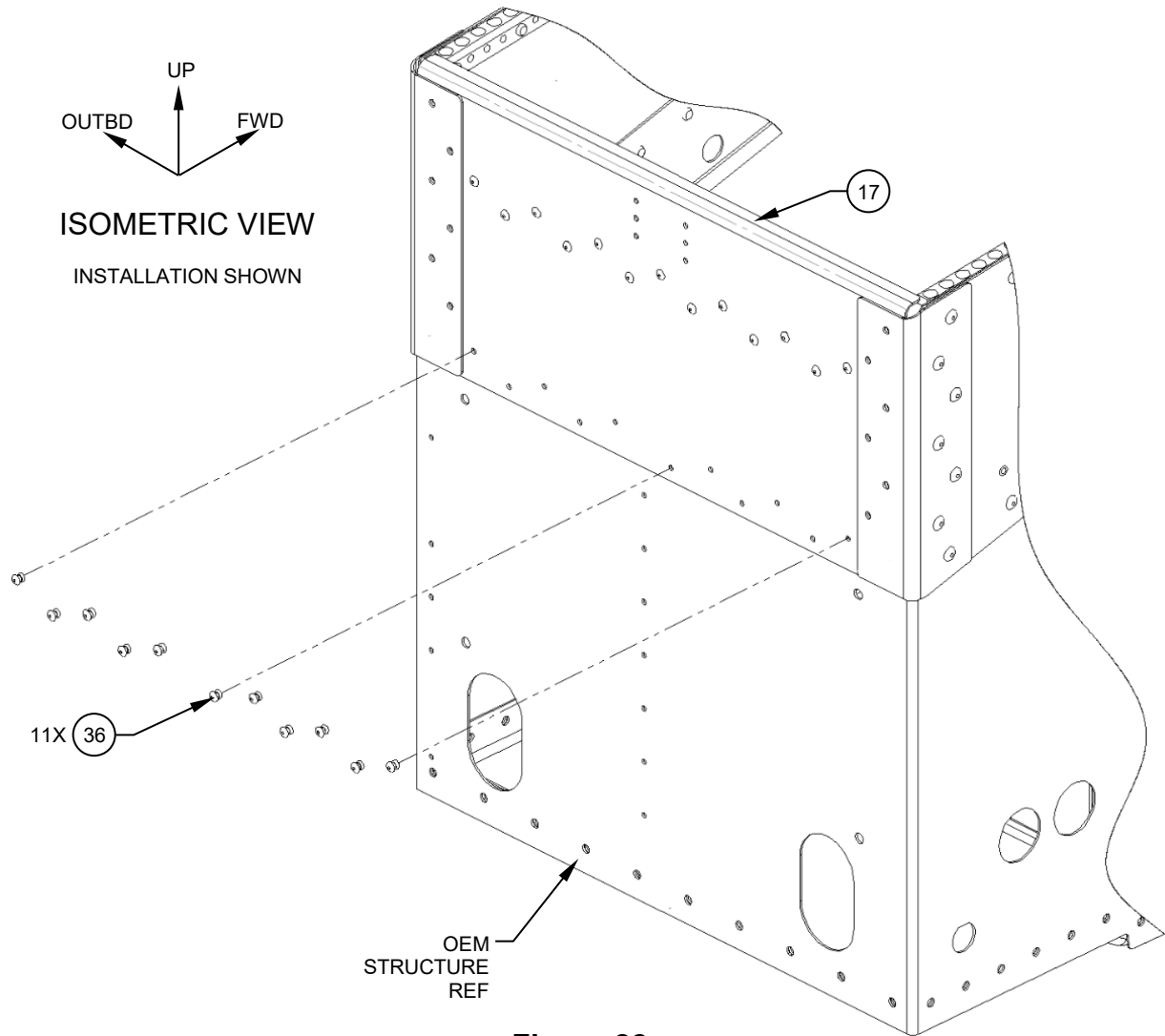

Figure 22

4.13. Back drill 10x Rivet, Solid, Universal Head, (Item 35), thru the LHS/RHS Angle, Details, (Items 21 & 22), & AFT Angle, Assy, (Item 17). Back drill 2x Rivet, Solid, Universal Head, (Item 33), thru the LHS/RHS Angle, Details, (Items 21 & 22), & AFT Angle, Assy, (Item 17). See Figure 23.

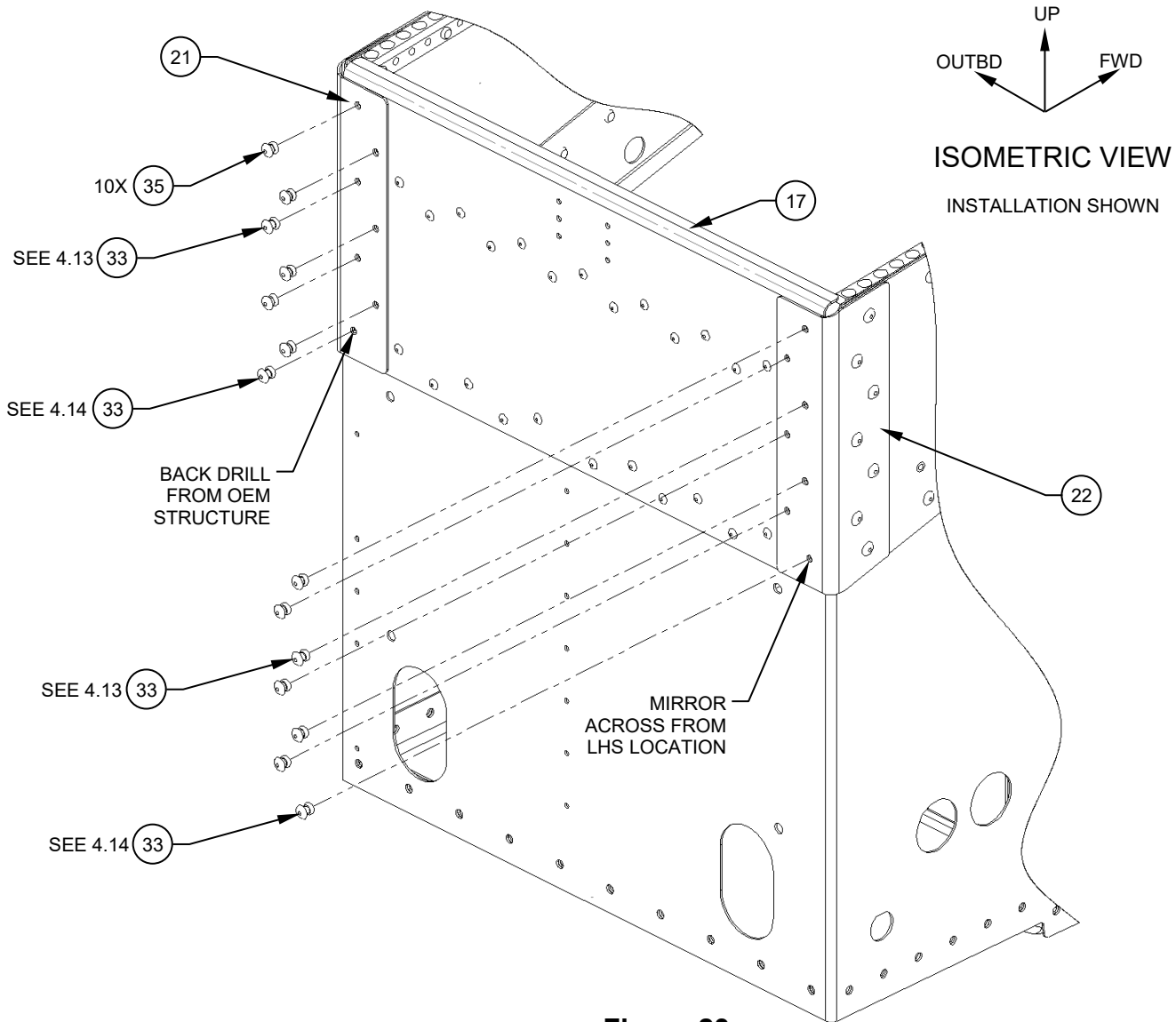

Figure 23

4.14. Back drill from the OEM structure thru the AFT Angle, Assy, (Item 17), LHS Angle, Details, (Item 21), and 1x Rivet, Solid, Universal Head, (Item 38). Mirror the location across to the RHS Angle, Details, (Item 22), and drill thru the AFT Angle, Assy, (Item 17), and OEM structure, and 1x Rivet, Solid, Universal Head, (Item 38). See Figure 23.

5. Re-installing the OEM Defrost Fitting.

5.1. Countersink the back side of the OEM Defrost Fitting, and plug the FWD OEM countersunk hole with 1x Rivet, Solid, Countersunk, Detail (Item 33). Ensure the shop head is on the backside, and is flush with the back surface. See Figure 25.

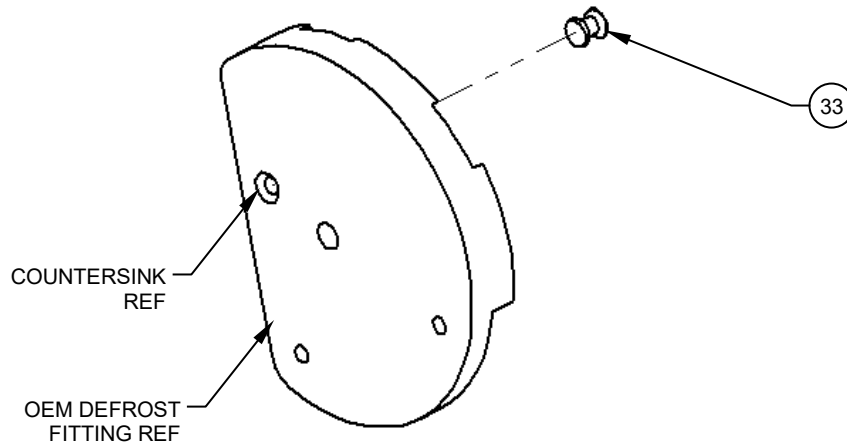

Figure 25

5.2. Back drill the lower and AFT mounting holes for the OEM defrost fitting, from the OEM structure thru the RHS Angle, Assy, (Item 6), using a #30 drill. See Figure 26.

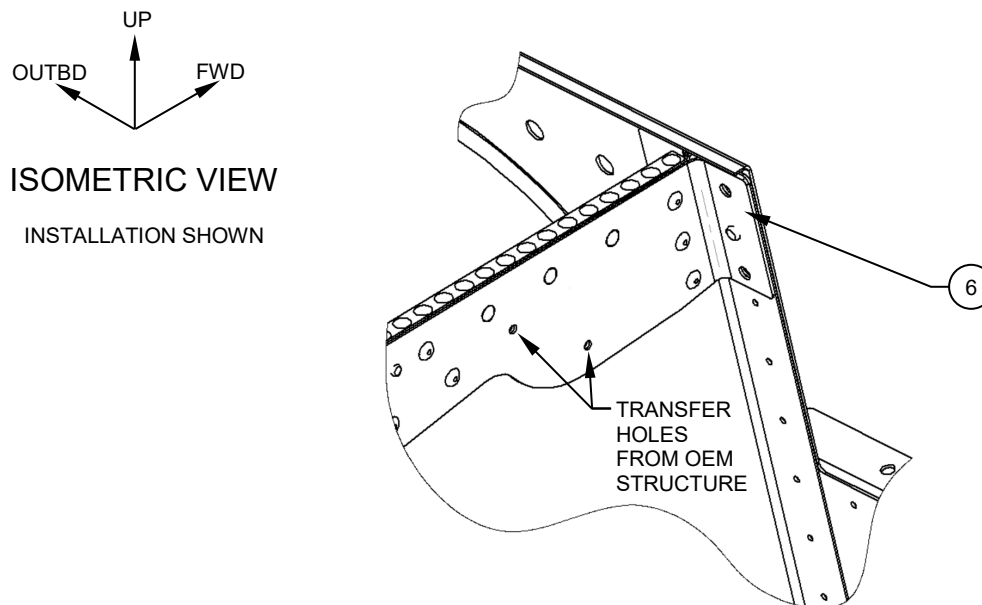

Figure 26

5.3. Temporarily install the OEM defrost fitting using cleco's. Back drill from the OEM fitting axle hole thru the RHS Angle, Assy, (Item 6), using a #10 drill. This should create a small notch on the lower edge of the Dzus Rail, Detail, (Item 11). See Figures 27 & 28.

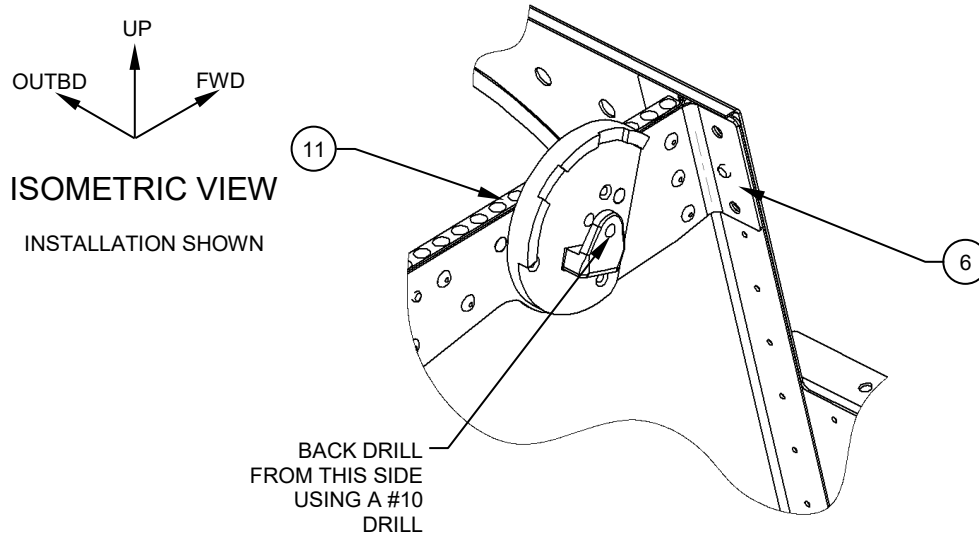

Figure 27

5.4. From the Dzus Rail, Detail, (Item 11), using the hole AFT of the second instance of the rivet pattern drill thru using a #30 drill, countersink the OUTBD side of the OEM defrost fitting for 1x Rivet, Solid, Countersunk Head, (Item 42). See Figure 28.

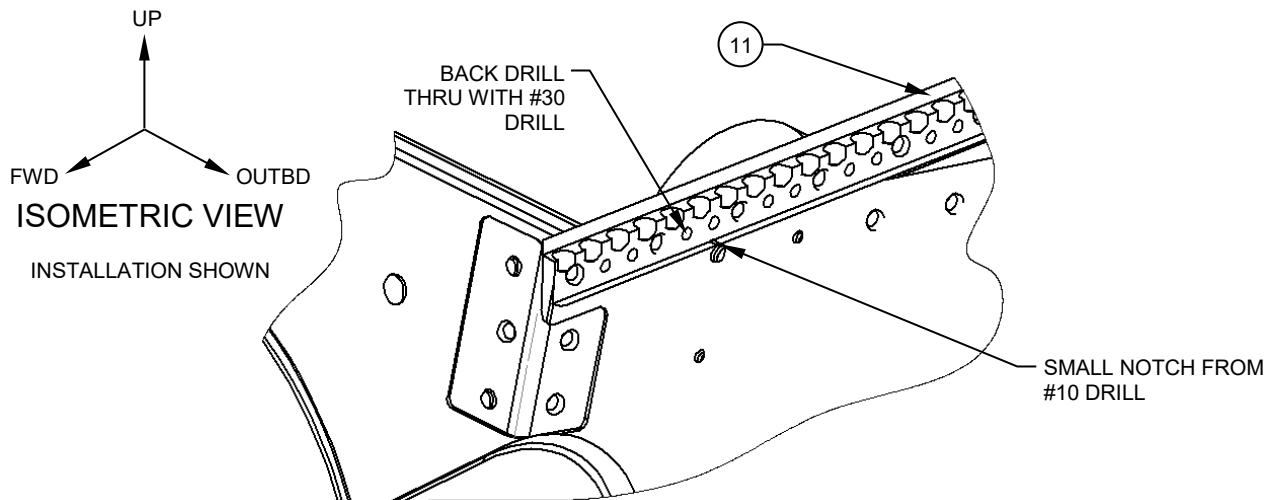
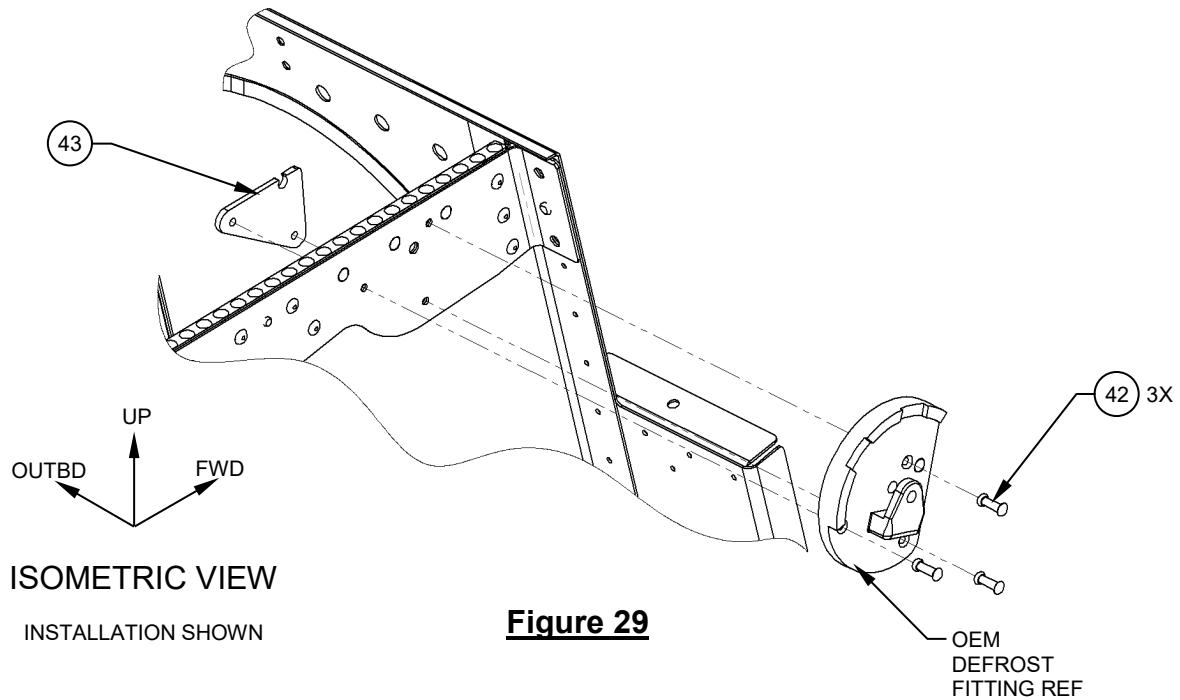

Figure 28

5.5. Install the OEM defrost fitting, using the Filler, Detail, (Item 43), on the INBD side, with 3x Rivet, Solid, Countersunk Head, (Item 42). See Figure 29.



5.6. Re-install the OEM defrost linkage using the original hardware.

5.7. The perimeter sheet metal is now installed. See the next section for panel layout and installation instructions.

6. Panel layout and installation instructions.

- 6.1. The design of the Center Pedestal Riser, Kit allows the installer maximum flexibility to configure the layout of instruments for optimal use.
- 6.2. This can range from, leaving the layout as full-length rack mount, only utilizing the Center Pedestal Riser, Kit to either fit longer avionics at the AFT end. Or changing the angle of the pedestal to enhance viewability of the existing instruments. Or having multiple transitions between rack mount and panel mount sections, to enable the operator to configure their avionics in the most efficient and safe manner.
- 6.3. In the following section, two different possible combinations will be shown. The first will be a single transition from rack mount to panel mount. The second will be multiple transitions between rack mount to panel mount. Some considerations need to be applied regardless of the configuration and will not be reiterated in both sections.

6.4. Single Transition

- 6.4.1. The first thing to consider is that the fuel and hydraulic switch control modules take up the first 24 rows of possible Dzus fasteners on the FWD RHS of the pedestal. This makes the first transition from rack mount to panel possible at row 25 or AFT. See Figure 30.

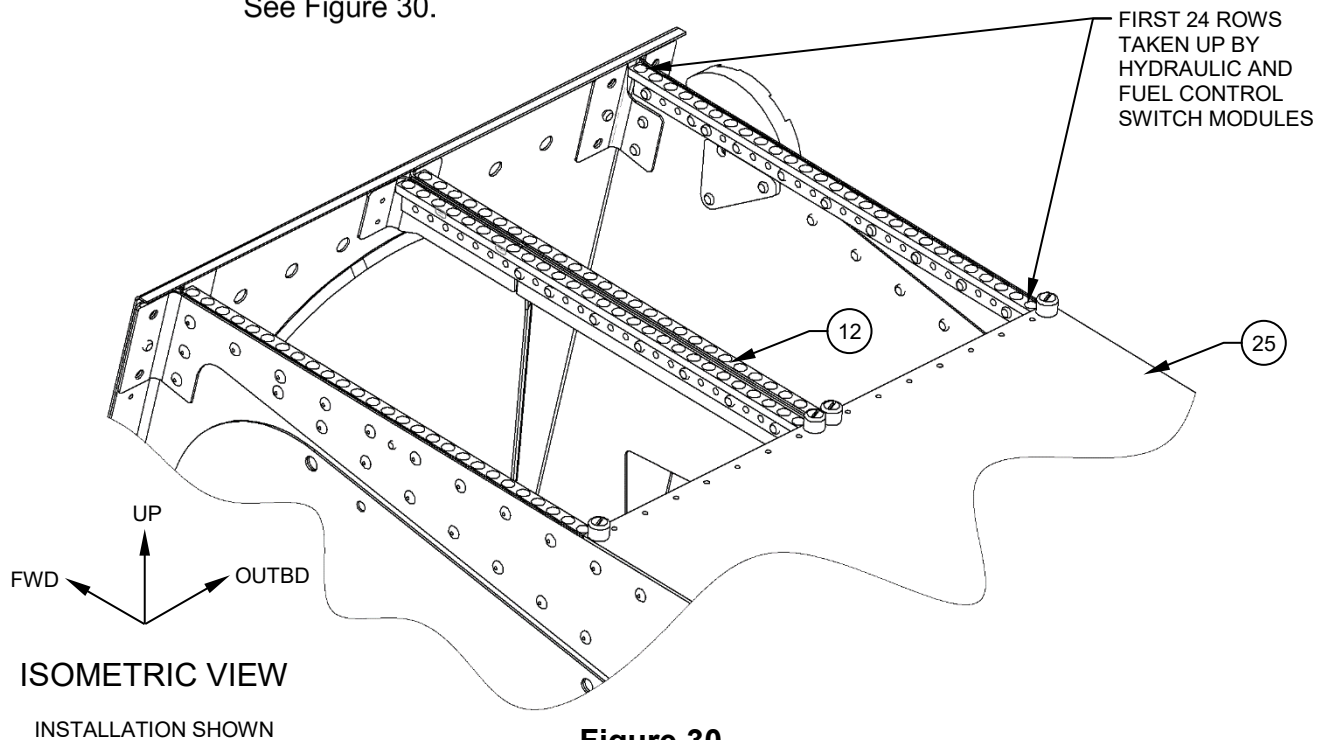

Figure 30

- 6.4.2. For this sample configuration the assumption being made is all avionics directly AFT of the of the fuel control switch module will be of the panel mount style, to the AFT end of the Center Pedestal Riser, Kit. See Figure 30.
- 6.4.3. Temporarily install the Center Dzus Rail, Assy, (Item 12), with 2X Filler, Detail, (Item 40), and the Panel Mount Plate, Assy, (Item 25). Remove and trim the Center Dzus Rail, Assy, (Item 12), after the 25th hole, leaving the edge distance shown. See Figures 30 & 31.

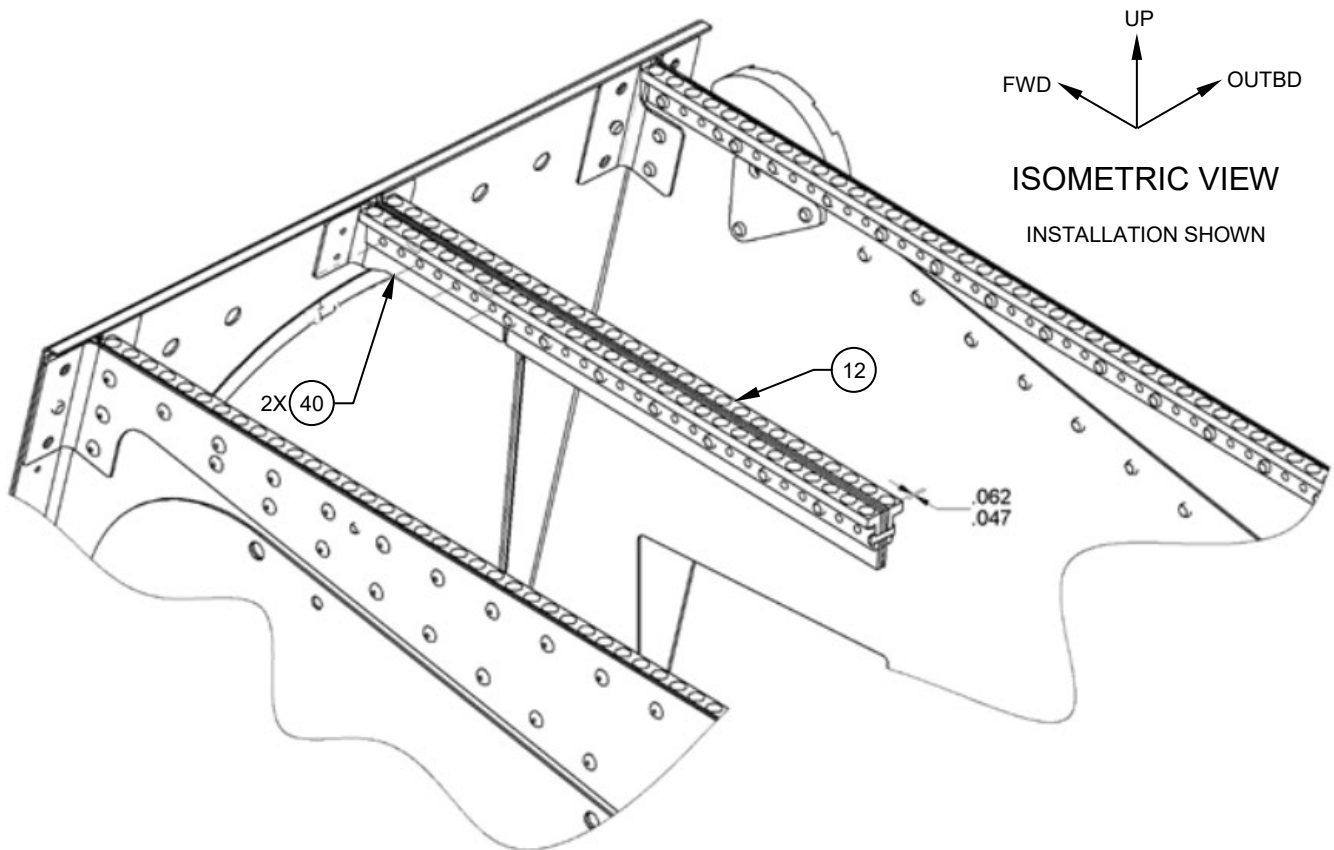

Figure 31
Some Items
Removed for
Clarity

- 6.4.4. For this application the AFT end of the Panel Mount Plate, Assy, (Item 25), extends to the AFT of the Center Pedestal Riser, Kit. The LHS/RHS AFT Bracket, Details, (Items 23 & 24) are not required and can be discarded. See Figure 9, on page 13.

6.4.5. Measure the center to center distance of the desired hole pitching on the Dzus Rail, Detail, (Item 11). Transfer that distance to the Panel Mount Plate, Assy, (Item 26), on both sides and maintaining the same edge distance, and drill with a letter F drill, countersink the backside $\text{Ø}.327 \times 100^\circ$. Measure $.188$ " from the center of the AFT holes to set the edge for the AFT end of the panel. See Figure 32 & 33.

Note: The installer may want to perform this procedure on a scrap piece of aluminum to verify your pitching is correct.

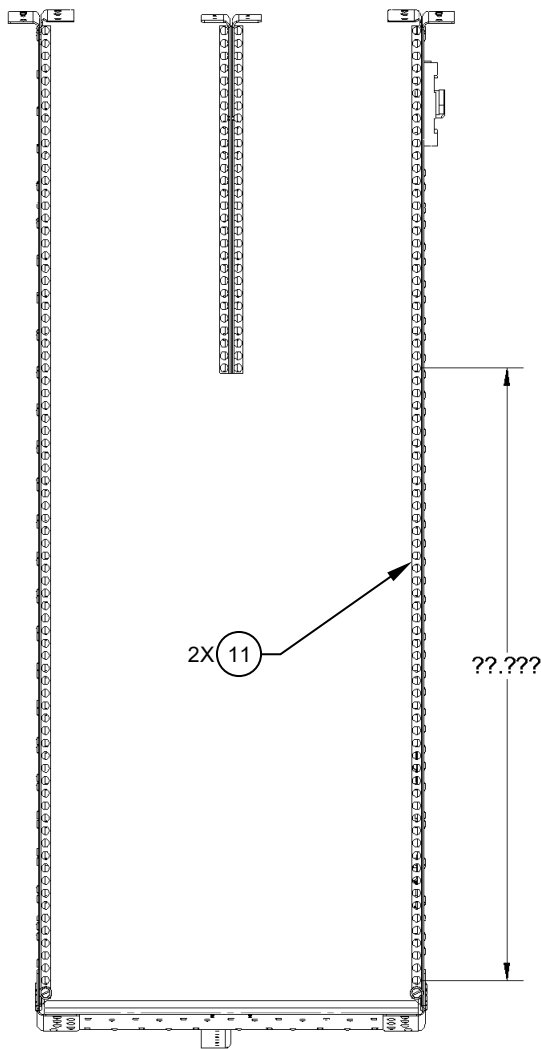

Figure 32
Some Items
Removed for
Clarity

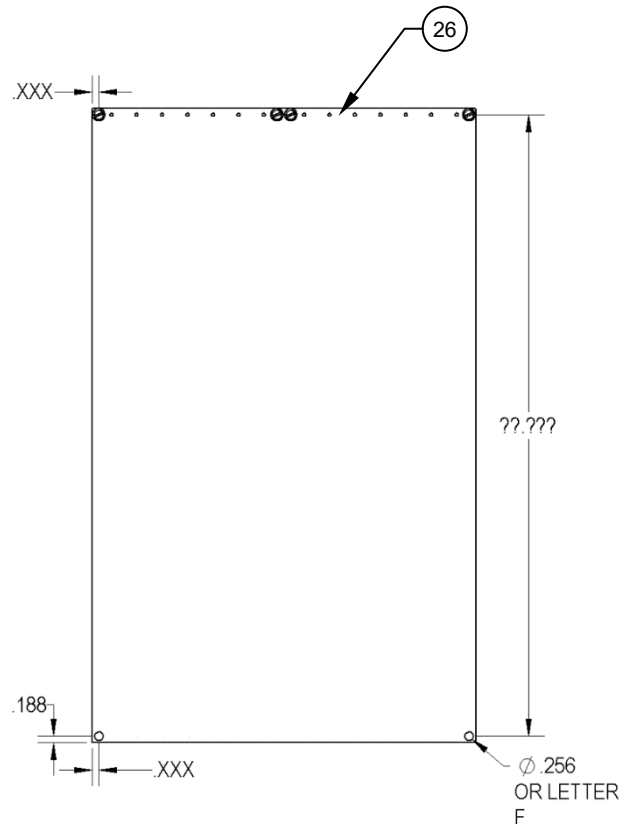

Figure 33

6.4.6. Temporarily install the Drill Template, Detail, (Item 41), to the Panel Mount Plate, Assy, (Item 25), at the AFT end and transfer the rivet locations for 14x Rivet, Solid, Countersunk Head, (Item 39). Omit the 2x center locations for Fastener, Panel, Stud, ¼ Turn, (Item 45). See Figure 34.

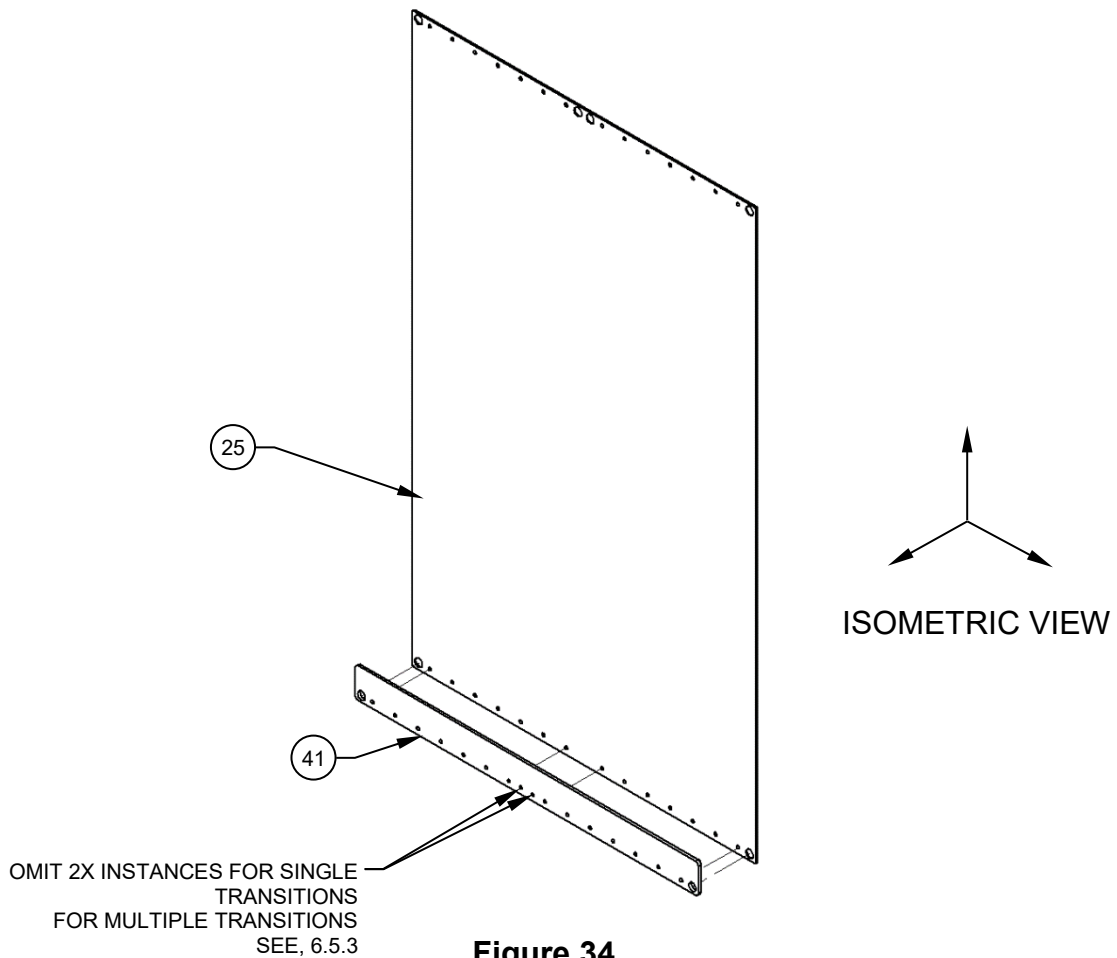
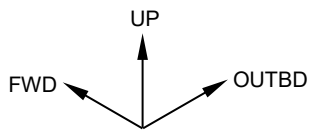
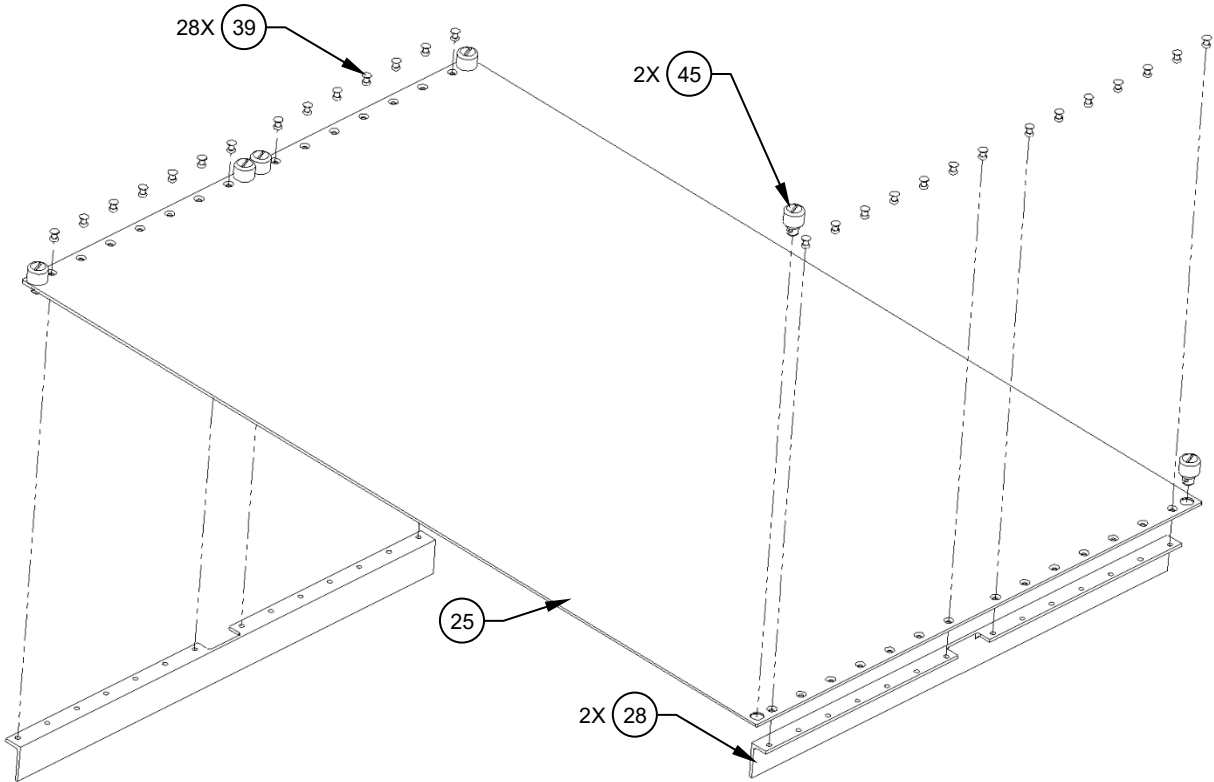

Figure 34
Some Items
Removed for
Clarity

6.4.7. Countersink the Panel Mount Plate, Assy, (Item 25), for 28x Rivet, Solid, Countersunk Head, (Item 39), and rivet the 2x Angle, Detail, (Item 28). Using the manufacturers tool, install 2x Fastener, Panel, Stud, 1/4 Turn, (Item 45). See Figure 35.



ISOMETRIC VIEW

INSTALLATION SHOWN

Figure 35

6.4.8. Measure the width and the combined height of all of the panel mount instruments to be installed and use that data to cut the opening in the face of the Panel Mount Plate, Assy, (Item 25). Regardless of the opening size in the face of the Panel Mount Plate, Assy, (Item 25), the length of the L Extrusion, Aluminum, (Item 29) should be so that there is **no more than a .030" gap** between the ends and the Angle, Detail, (Item 28). Plot an appropriate staggered rivet pattern on both pieces of the L Extrusion, Aluminum, (Item 29), drill thru #40 for rivets, (Item 39). See Figure 36.

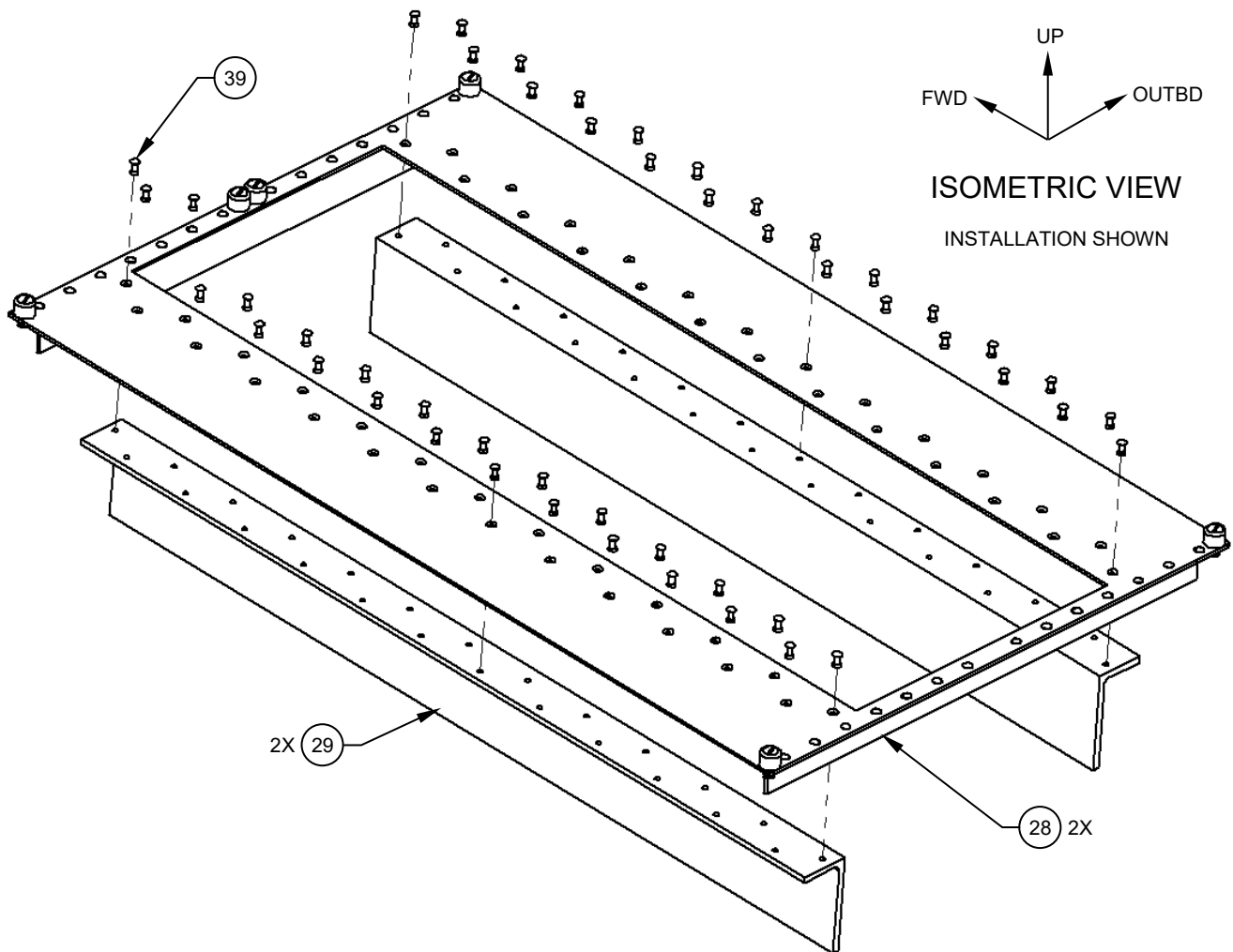

Figure 36

6.4.9. Position the L Extrusion, Aluminum, (Item 29), so that they are centered front to back and flush to the edges of the cutout in the face of Panel Mount Plate, Assy, (Item 25). Transfer the rivet pattern, countersink and rivet using the appropriate number of Rivet, Solid, Countersunk Head, (Item 39). See Figure 36.

6.4.10. Permanently install the modified Panel Mount Plate, Assy, (Item 25), and the modified Center Dzus Rail, Assy, (Item 12) with the 2X Filler, Details, (Items 40), on to the Center Pedestal Riser, using 2x Rivet, Solid Universal Head, (Item 37). Install at least one more Fastener, Panel, Stud, ¼ Turn, (Item 45) on each side. See Figure 37.

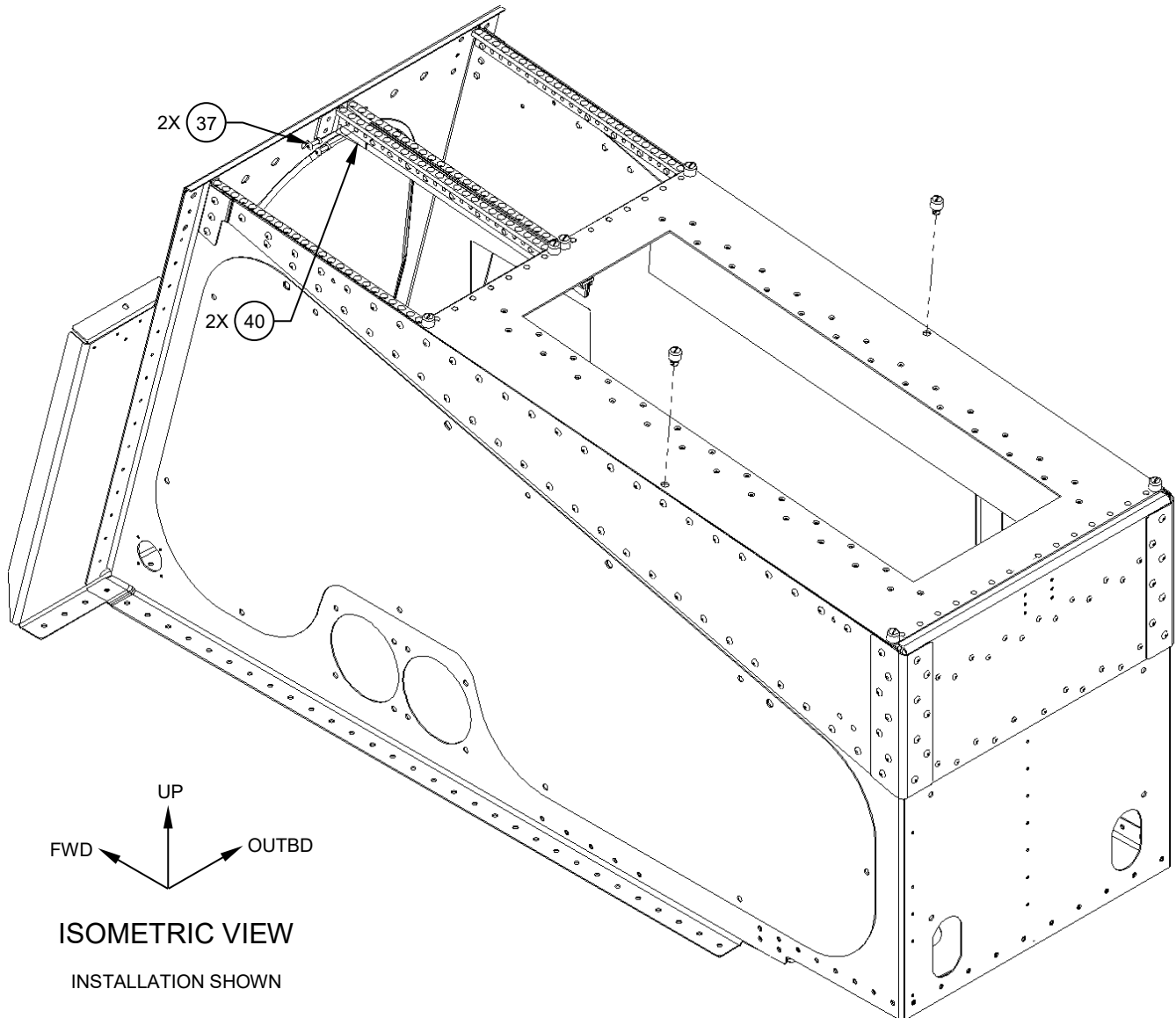

Figure 37

6.4.11. Process IAW general notes 6 thru 7.

6.4.12. Reinstall all retained avionics. Install new avionics per manufacturer's instructions.

6.4.13. Installation complete.

6.4.14. Perform a General Inspection of all Items to ensure proper installation.

6.4.15. Update the aircraft logbook for the installation of the AAL Center Pedestal Riser, Kit.

6.5. Multiple Transitions

6.5.1. As the Panel Mount Plate, Assy, (Item 25), will not extend to the AFT end of the Center Pedestal Riser, Kit, the first step is to determine how many positions on the Dzus rail a specific set of instruments will take up.

6.5.1.1. To do this the first step is to measure the physical stack up of the instrument chassis. Do not use the manufacturers nominal published dimensions. Record this dimension. Add .500" to this dimension. Divide the result by .375, if the number divides evenly, this is your number of positions taken up. If the number does not divide evenly, round the number **UP** to get the number of positions taken up. See Figure 38 for examples.

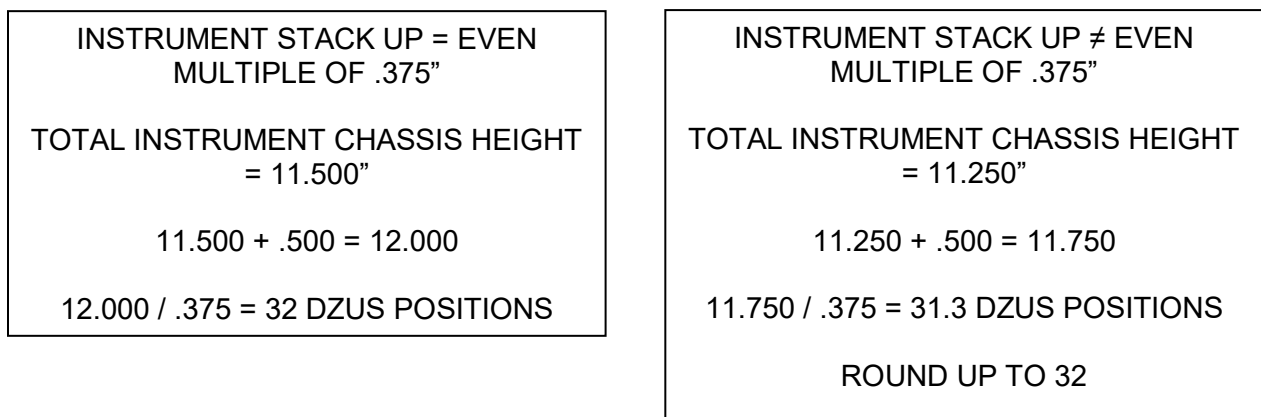

Figure 38

6.5.2. Measure the actual center to center distance between the number of Dzus positions required in step 6.5.1.1.

6.5.3. If you are cutting the Panel Mount Plate, Assy, (Item 25) for the first time follows steps 6.4.5 thru 6.4.9. When you use the Drill Template, Detail, (Item 41), use as in step 6.4.6, and then drill through the two omitted center holes and upsize to .256" letter F drill and countersink the backside $\text{\O} .327 \times 100^\circ$ for 2x Fastener, Panel, Stud, $\frac{1}{4}$ Turn, (Item 45). Then trim the length of the Panel Mount Plate, Assy, (Item 25), .188" past the center of the AFT row of fasteners. See Figures 33 & 34.

6.5.4. Cut the opening in the face of the Panel Mount Plate, Assy, (Item 25), per the stack up height and width of the chassis.

- 6.5.5. Install the 2x Angle, Detail, (Item 28), and 2x L Extrusion, Aluminum, (Item 29), as per 6.4.7 thru 6.4.9.
- 6.5.6. If you have already used the FWD section of the Panel Mount Plate, Assy, (Item 25), to make the first panel, you will use the remaining material to make any additional panels required.
- 6.5.7. Place the Drill Template, Detail, (Item 41), on the remaining material. Line up the top edges of material. Transfer and drill off all holes into the remnant material. Upsizing to .256" letter F drill and countersink the backside $\text{\O} .327 \times 100^\circ$ for 4x Fastener, Panel, Stud, $\frac{1}{4}$ Turn, (Item 45).
- 6.5.8. Calculate the Dzus positions the new panel will take up per 6.5.1.1. Plot the AFT Dzus fastener holes and drill .256" letter F drill and countersink the backside $\text{\O} .327 \times 100^\circ$. Use the Drill Template, Detail, (Item 41), per 6.4.6 & 6.5.3. Leaving the same edge distance AFT of the fastener line per 6.5.3.
- 6.5.9. Install the 2x Angle, Detail, (Item 28), and 2x L Extrusion, Aluminum, (Item 29), as per 6.4.7 thru 6.4.9.
- 6.5.10. Refer to the Center Dzus Rail, Assy, (Item 12) being assembled with the 2X Filler, Details, (Item 40), and the OEM brackets. Assemble the 1x AFT LHS Bracket, Detail, (Item 23) and the 1x RHS AFT Bracket, Detail, (Item 24) with 4x Rivet, Solid, Universal Head, (Item 37). See Figures 8 & 13 in sections 2.11 & 3.2.
- 6.5.11. Trim the Center Dzus Rail, Assy, (Item 12), as per section 6.4.3. allowing for one extra Dzus hole position at the FWD & AFT of each section of Center Dzus Rail, Assy, (Item 12), based on the Dzus positions required for the individual rack mounted instruments. See Figure 38.
- 6.5.12. Install the Panel mount sections in their appropriate locations. Then attach the trimmed sections of the Center Dzus Rail, Assy, (Item 12) in between the panel mount sections. Rivet the FWD section of the Center Dzus Rail, Assy, (Item 12) as per section 6.4.10. Rivet the AFT section of the Center Dzus Rail, Assy, (Item 12), to the Aft Angle, Assy, (Item 17), with 6x Rivet, Solid, Universal Head, (Item 38). See Figure 39.

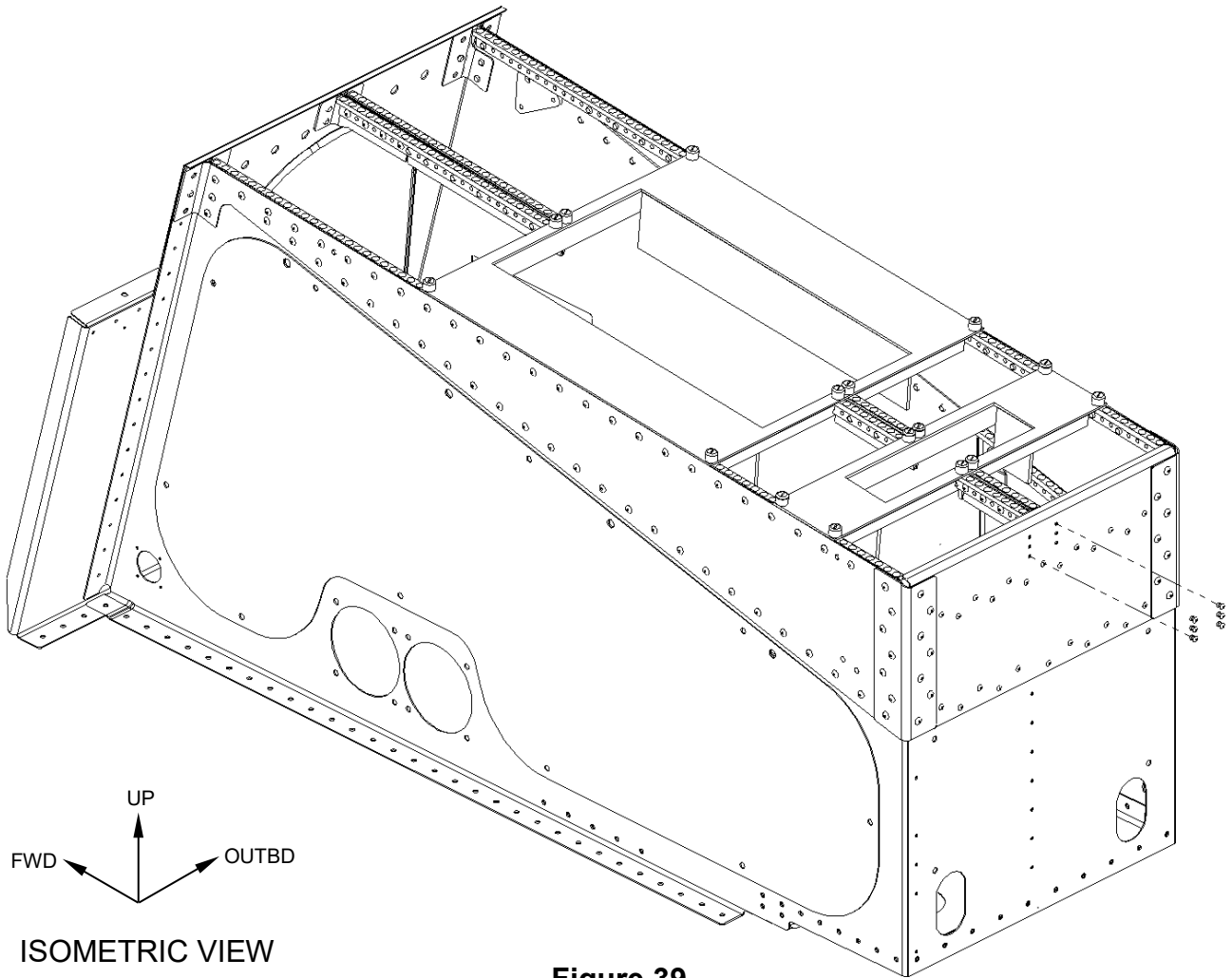

ISOMETRIC VIEW

INSTALLATION SHOWN

Figure 39

6.5.13. Paint & process IAW general notes 6 & 7, and, IAW customer requirements.

6.5.14. Reinstall all retained avionics. Install new avionics per manufacturer's instructions.

6.5.15. Installation complete.

6.5.16. Perform a General Inspection of all Items to ensure proper installation.

6.5.17. Update the aircraft logbook for the installation of the AAL Center Pedestal Riser, Kit.

Section 3 Removal Instructions

- 3.1. The installation of the Center Pedestal Riser, Kit, is considered permanent. As such there are no removal instructions.