

BASIC DIGITAL FLIGHT INSTRUMENT, KIT INSTRUCTIONS FOR CONTINUING AIRWORTHINESS

MODELS: BELL 212

Read all of the Instructions for Continuing Airworthiness
thoroughly prior to performing any activities relating to this product

Table of Contents

<u>SECTION</u>	<u>DESCRIPTION</u>	<u>PAGE</u>
1	Introduction	2
	Applicability	2
2	Description	3
3	Operation	4
4	Maintenance Instructions	7
5	Troubleshooting	10
6	Removal/Replacement	11
	Removal Instructions	12
	Replacement Instructions	14
7	General	15
8	Airworthiness Limitations	16
9	Illustrated Parts Breakdown	17
Appendix: A	Electrical Connections	27

Notes

1. If changes to this document are required, Alpine Aerotech LP shall revise all pages and reissue the entire document.
2. Alpine Aerotech LP shall publish any subsequent revisions of this document to be made freely available. Alpine Aerotech LP also recommends that the end user of this product periodically verify the revision level of this document.

SECTION 1 Introduction

This document comprises Instructions for Continuing Airworthiness that apply to AAL Basic Digital Flight Instrument, Kit installed on Bell 212 rotorcraft. The information and data contained in this document are supplemental to the information contained in the existing ICA for the Bell 212.

Applicability

The Basic Digital Flight Instrument, Kit (AAL-280-040-901/902/-903) is applicable to all serial numbers of Bell 212 rotorcraft including aircraft equipped with co-pilot instrumentation per 212-SI-1 and 212-SI-41.

SECTION 2 Description

The following information provides a functional description of the Basic Digital flight Instrument, Kit as defined in Alpine Aerotech LP authority dataset AAL-280-040-901/-902/-903.

The AAL Basic Digital Flight Instrument, Kit allows for the replacement of the OEM attitude and heading instruments with standalone digital instruments. Three different configurations are available: pilot (RHS) only instrumentation, co-pilot (LHS) only instrumentation and combined pilot and co-pilot instrumentation.

SECTION 3 Operation

Heading Indicator

1. START UP

On power-up, heading indicator will display a blue self-test, screen followed by a prominent red “X” across the face of the display. Once the “X” has disappeared the instrument has completed its startup procedure. The red “X” should not be displayed for more than three minutes.

2. DIMMER

The heading indicator has brightness adjustments that can be adjusted in flight. On start-up, the instrument defaults to maximum brightness. The brightness controls are located at the top of the instrument and have an “up” (▲) arrow next to the button that increases brightness and a “down” (▼) arrow next to the button that reduces brightness. Reference Figure 1. Quickly pressing both buttons simultaneously will return the display to its maximum brightness.

CAUTION

Pressing and holding both “DIM” buttons simultaneously for 10 seconds will put the heading indicator into Magnetic Calibration Mode. Reference paragraph 4, “Magnetic Calibration”.

3. MAG MODE / NO GPS MODE

On the heading instrument, the “MAG MODE” and “NO GPS” mode indicators will be lit on start-up. The “MAG MODE” indicator signifies that the instrument does not have a GPS signal and is operating as a magnetic heading indicator. Reference Figure 1. The “MAG MODE” indicator will stay lit until the instrument is able to acquire a GPS signal and/or the aircraft reaches a speed exceeding ten knots at which time the GPS input will become active. In the event the heading indicator loses GPS signal in flight, the “NO GPS” indicator will illuminate. The instrument will continue to work as a magnetic heading instrument and no special intervention is required on the part of the flight crew.

4. MAGNETIC CALIBRATION

Magnetic calibration should be performed on initial installation, every time new instruments or electrical devices are installed on the aircraft that could affect the magnetic signature of the aircraft and at any time when unacceptable deviations in heading are noted. See Section 7 for Magnetic Calibration procedures.

5. EXTREME MANEUVERS

Extreme control inputs may cause the heading and attitude indicators to become temporarily disabled. This is indicated by a prominent red “X” displayed across the screens and an “Exceed Acc (acceleration) Limit” warning notice on the heading indicator and an “Exceed Bank Angle” warning notice on the attitude indicator. The instruments should automatically reset their respective displays in three to ten seconds after conclusion of the hard maneuver. This information is provided for reference only as the ability of the instruments to respond to extreme maneuvers is beyond the abilities of the aircraft as described in the Basic Flight Manual. The instruments will operate in a full 360° pitch & roll, and 360° of turn.

In the unlikely event that the instruments do not reset themselves after displaying “Exceed Acc (acceleration) Limit” or “Exceed Bank Angle” warnings, reset them manually by cycling power to the instruments via the circuit breakers located on the overhead breaker panel. This will cause the instruments to reboot and go through the standard start-up routine. You do not need to be in level flight while the instruments re-start. If the instruments fail to re-start, land the aircraft using visual reference at the first appropriate opportunity.

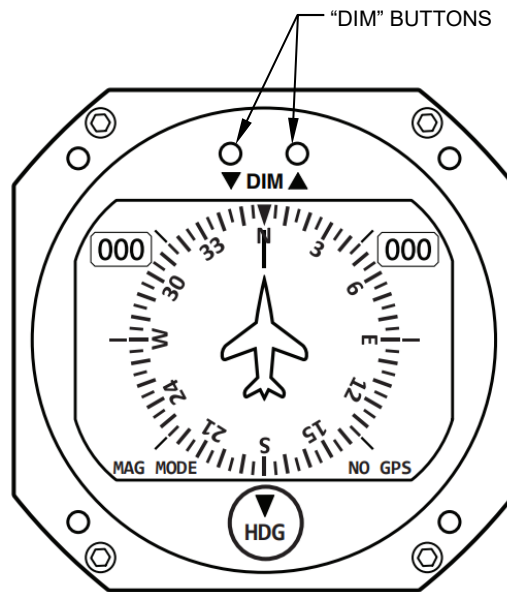

Figure 1
Heading Indicator shown

Attitude Indicator

1. START UP

On power-up, the attitude indicator will display a blue self-test, screen followed by a prominent red “X” across the face of the display. Once the “X” has disappeared the instrument has completed its startup procedure. The red “X” should not be displayed for more than three minutes.

2. DIMMER

The attitude indicator has brightness adjustments that can be adjusted in flight. On start-up, the instrument defaults to maximum brightness. The brightness controls are located at the top of the instrument and have an “up” (▲) arrow next to the button that increases brightness and a “down” (▼) arrow next to the button that reduces brightness. Reference Figure 2. Pressing both buttons simultaneously will return the display to its maximum brightness.

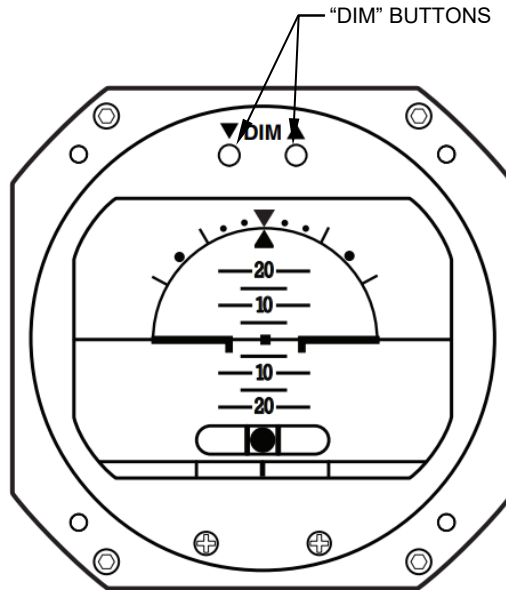

Figure 2
Attitude Indicator shown

SECTION 4 Maintenance Instructions

General Notes

1. The following information defines the instructions for continuing airworthiness, repair allowances and airworthiness limitations for the item(s) referenced within this document.
2. Refer to the current revision of the BHT Maintenance Manual, BHT-212-MM, for the chapter(s) and section(s) referenced within this document.
3. Refer to the Section 6: Removal/Replacement and Section 9: Illustrated Parts Breakdown for the replacement and/or installation of the item(s) referenced within this section.
4. Scheduled inspection for the item(s) referenced within this document shall be accomplished in accordance with (IAW) the Inspection Procedures specified.
5. Repair allowances for the item(s) referenced within this document shall be accomplished IAW Section 5, Troubleshooting.
6. Limitations for the item(s) referenced within this document are IAW Section 8, Airworthiness Limitations.
7. Record instrument serial numbers in the table provided below for future reference.

Pilot (RHS) Attitude S/N		Co-pilot (LHS) Attitude S/N	
Pilot (RHS) Heading S/N		Co-pilot (LHS) Heading S/N	

Inspection Procedures

Supplement to applicable Maintenance Manual, Chapter 5, Inspection and Component Overhaul Schedule

Notes

1. Refer to the applicable Maintenance Manual, Chapter 5, for general information on inspections, inspection definitions, inspection intervals, inspection methods and inspection schedules.
2. General Inspections, as indicated within this document, are defined as visual, non-thorough checks.
3. Detailed Inspections, as indicated within this document, are defined as visual and thorough, searching checks.
4. Perform Daily Inspections every day, prior to flight operation. If damage is detected, perform the 300 Hour/12 Month Inspections.
5. Perform 300 Hour/12 Month Inspections every 300 hours or every 12 months, whichever occurs first, prior to flight operation. If damage is detected, refer to the Repair Procedures section within this document.

Scheduled Inspections

1. Daily Inspections

Data Reference: Section 6: Removal/Replacement
Section 9: Illustrated Parts Breakdown

- i. Perform a General Inspection on all items in the Basic Digital Flight Instrument, Kit for general condition.
- ii. Perform a General Inspection on all items in the Basic Digital Flight Instrument, Kit for proper security.
- iii. Perform a general function test on both heading and attitude indicators by powering up the instruments. The red "X" that appears on the screen should disappear after approximately three minutes. If the red "X" does not disappear the instrument is unserviceable. Refer to Section 5, Troubleshooting.

2. 300 Hour/12 Month Inspections

Data Reference: Section 6: Removal/Replacement
Section 9: Illustrated Parts Breakdown

- i. Perform a Detailed Inspection on all materials and finishes in the Basic Digital Flight Instrument, Kit for evidence of corrosion and damage.
- ii. Perform a Detailed Inspection on all wiring harnesses, antennas and electrical components in the Basic Digital Flight Instrument, Kit for evidence of corroded contacts, chafing or any other type of mechanical damage and or wear.
- iii. Perform a Detailed Inspection on all items, materials and finishes in the Basic Digital Flight Instrument, Kit for proper integrity and condition.
- iv. Perform a Detailed Inspection on all hardware and fasteners in the Basic Digital Flight Instrument, Kit for proper security and torque.

CAUTION

Use extreme care when handling the instruments and avoid touching the screen if at all possible. For proper care and handling refer to Kelly Manufacturing publication No. 1401-5 for the Heading Indicator and No. 1401-3 for the Attitude Indicator.

SECTION 5 Troubleshooting

1. If either an Attitude or Heading Indicator is unserviceable, replace with a serviceable unit. Contact Kelly Manufacturing for all questions and issues related to the Heading and Attitude Indicators.
2. Repairs to all other item(s) referenced within this document are **not** permitted. Contact Alpine Aerotech LP for further information if repairs are required to all other item(s) referenced within this document.

SECTION 6 Removal/ Replacement

General Notes

1. All Removal/Replacement instructions shall be accomplished in accordance with (IAW) standard aircraft practices. Refer to the current revision of the FAA Advisory Circular AC 43.13-1 and AC 43.13-2 for details on standard aircraft practices.
2. Torque fasteners IAW the tension type torque limits indicated in the most current revision of BHT-ALL-SPM, Chapter 2 unless otherwise specified.
3. All dimensions are in imperial measures (inches/pounds).
4. Refer to Section 4: Maintenance Instructions for instructions on maintenance for the item(s) referenced within this section.
5. Refer to Section 9: Illustrated Parts Breakdown for the part numbers of the item(s) referenced within this section.

Removal Instructions (all configurations)

1. Gain access to the aircraft and make the aircraft ready for maintenance.
2. Disconnect the Wiring Harnesses (Items 35 & 36) and Coax Cables (Item 37) and temporarily stow them. Reference Figure 3.

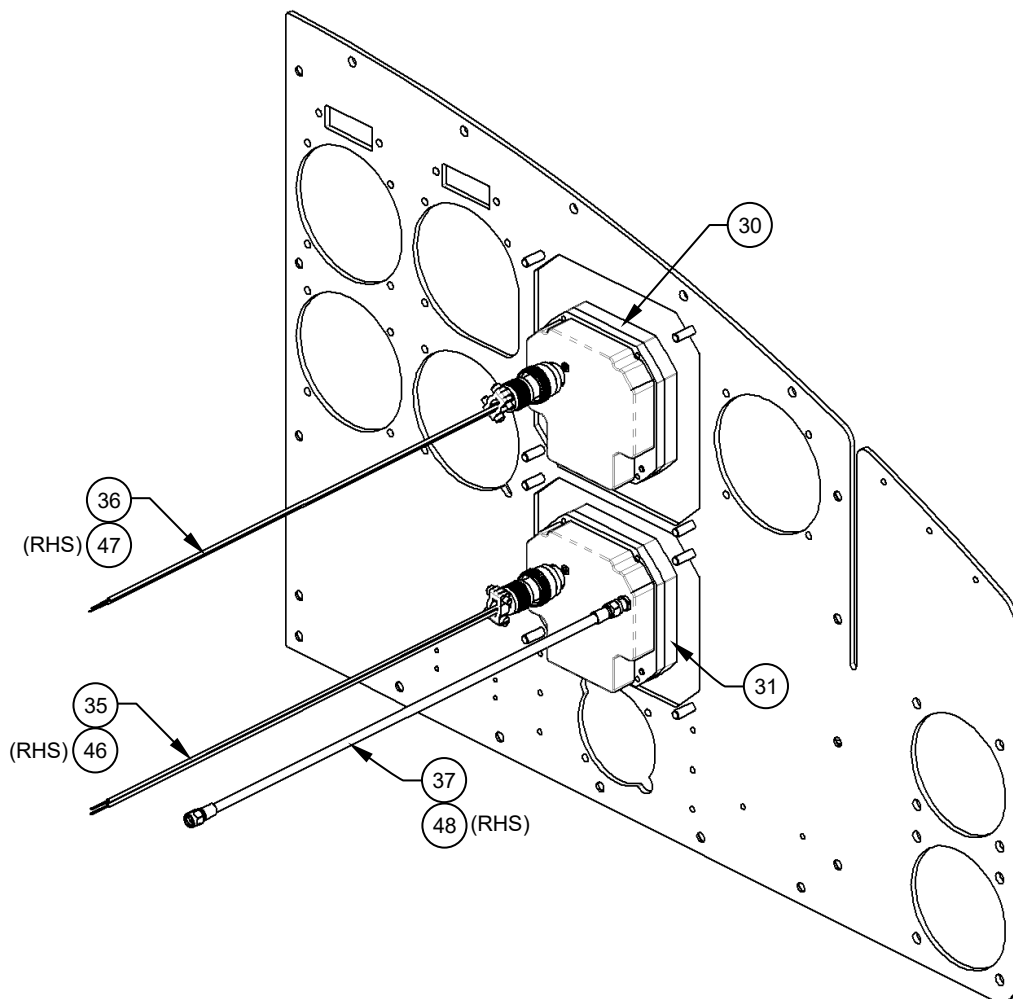

Figure 3
Instrument removal
LHS shown, RHS opposite

Removal Instructions (all configurations)

- Remove all fasteners (Item 32) common to the Adaptor, Detail (Item 28) and remove the Adaptor, Detail, the Attitude (Item 30) and Heading Indicators (Item 31) as a unit. If installed on an aircraft with a serial number of 30596 or earlier, remove Adaptor, Detail (Item 29) with the Attitude Indicator as a unit. Remove the Heading Indicator directly from the existing instrument panel. Reference Figure 4.

CAUTION

Use extreme care when handling the instruments and avoid touching the screen if at all possible. For proper care and handling refer to Kelly Manufacturing publication No. 1401-5 for the Heading Indicator and No. 1401-3 for the Attitude Indicator.

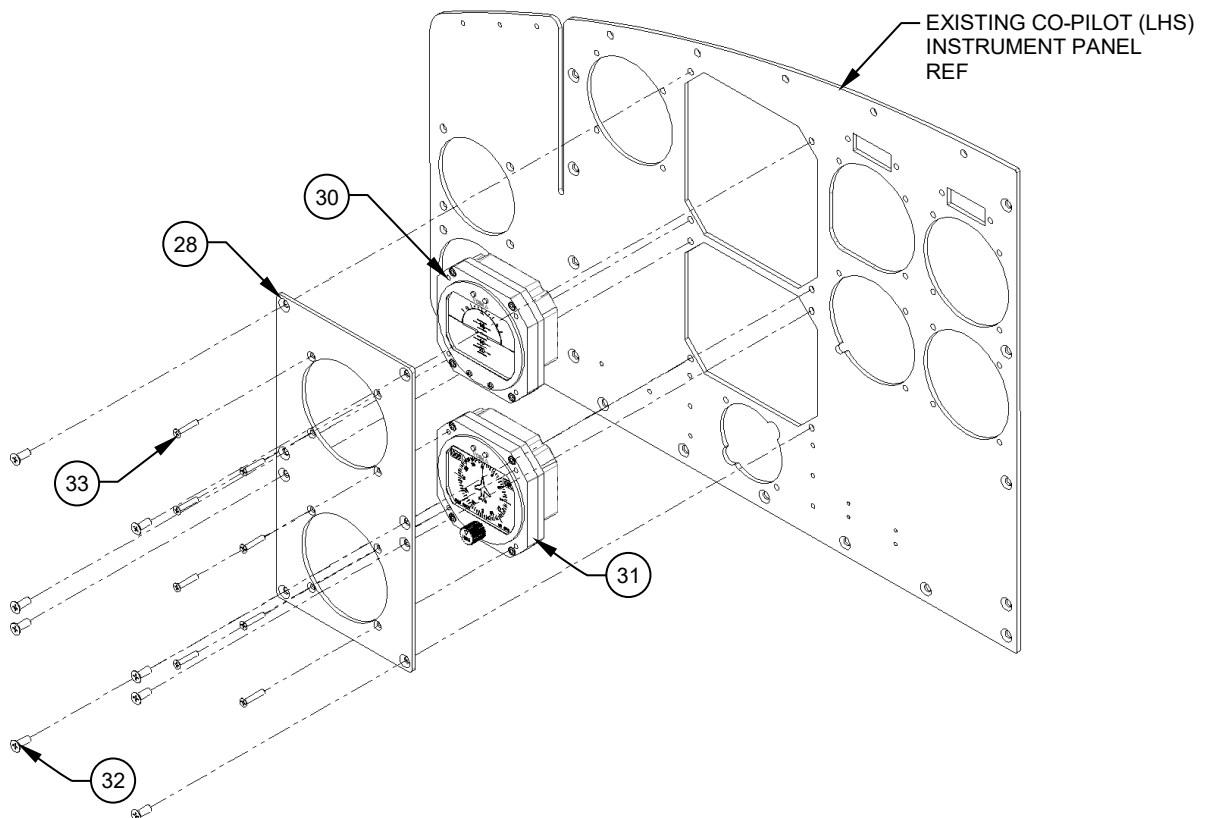

Figure 4
Instrument removal
LHS shown, RHS opposite

Removal Instructions (all configurations)

4. With the Adaptor, Detail and Attitude and Heading Indicators on a bench, remove all fasteners (Item 33) common to the instruments. Treat all unserviceable instruments as if they are new, to preserve the possibility of repair.
5. Refer to Section 5, Troubleshooting for information regarding the repair of unserviceable instruments.

Replacement Instructions (all configurations)

6. There are no special procedures for replacement of the Attitude (Item 30) and Heading (Item 31) Indicators; as such the replacement can be considered the opposite of the removal procedure.
7. Connect aircraft to external power and power up instruments. On initial start-up the instruments will show a blue "Self-Test" screen that will display a list of data including the instrument serial number. Record the serial number(s) in the ICA document as well as the logbook for future reference. After roughly 30 seconds the "Self-Test" will be cleared from the displays and a prominent red "X" will be displayed across the screens while the instrument initializes. The red "X" should not be present on the screens for more than 3 minutes.
8. Confirm that the instrument readings are stable.
9. Move the aircraft outside to allow the Heading Indicator(s) to acquire a GPS signal. The "NO GPS" indicator should extinguish once the signal is established.
10. Cycle power to the instruments one at a time using the associated circuit breakers in the overhead breaker panel to ensure proper breaker function.
11. Update the aircraft logbook for the replacement of the affected components of the Basic Digital Instrument, Kit.

SECTION 7 General

Magnetic calibration

1. Perform magnetic calibration procedure as detailed below (Heading Indicator(s) only).
 - i. While in flight, and after at least three minutes after turning on the instrument, depress and hold the two “DIM” buttons simultaneously for about ten seconds until the message “Gathering Mag Data” is displayed on the instrument. The instrument will gather data for the next ten minutes. Reference Figure 1.
 - ii. Within the next ten minutes perform four 360° turns; two to the right and two to the left alternately, while traveling at a speed greater than ten knots.

NOTE

The Heading Indicator requires a minimum forward speed of ten knots for the GPS to become active. At speeds below ten knots the instrument will operate as a magnetic heading indicator only and the “MAG MODE” indicator will be illuminated on the instrument.

- iii. When ten minutes has elapsed the instrument will display the message “Mag Data Saved”. Turn the instrument(s) off, then back on by cycling power to the instruments via the circuit breakers located on the overhead breaker panel. The message will then disappear and the instrument is calibrated for the magnetic field of the aircraft.
- iv. The magnetic calibration procedure should be repeated every time another instrument is added/removed or any significant change has been made to the electrical system that could change the magnetic signature of the aircraft.

NOTE

During the calibration procedure the Heading Indicator(s) could behave erratically due to the calibration process. This is normal.

- v. When the magnetic calibration procedure is complete, ensure proper function of the instruments.

SECTION 8 Airworthiness Limitations

The Airworthiness Limitations section is approved by the Minister and specifies maintenance required by any applicable airworthiness or operating rule unless an alternative program has been approved by the Minister.

The Airworthiness Limitations section is FAA approved and specifies maintenance required under Sections 43.16 and 91.403 of the Federal Aviation Regulations unless an alternative program has been FAA approved.

**Supplement to applicable Maintenance Manual,
Chapter 4, Airworthiness Limitations Schedule**

Notes





1. Refer to the BHT-212-MM, Chapter 4, for general information on airworthiness limitations and airworthiness limitation schedules.
2. Item(s) **not** listed in the Scheduled Airworthiness Limitations section within this document have an unlimited airworthiness life.

Scheduled Airworthiness Limitations

1. There are no airworthiness limitations associated with the item(s) referenced within this document.

SECTION 9 Illustrated Parts Breakdown

General Notes

1. Alternate items listed where applicable. Duplicate item numbers signify an alternate part number.
-  Typical item number for all like items in this view unless otherwise specified.
-  For Basic Digital Flight Instrument, Kit, LHS (AAL-280-040-902) omit all parts and sub-assemblies in Wiring Harness, Kit RHS (Item 45) and omit one Instrument, Kit (Item 27).
-  For Basic Digital Flight Instrument, Kit, RHS (AAL-280-040-903) omit all parts and sub-assemblies in Wiring Harness, Kit LHS (Item 34) and omit one Instrument, Kit (Item 27) .
-  Not provided, procure locally.

Illustrated Parts Breakdown (cont.)

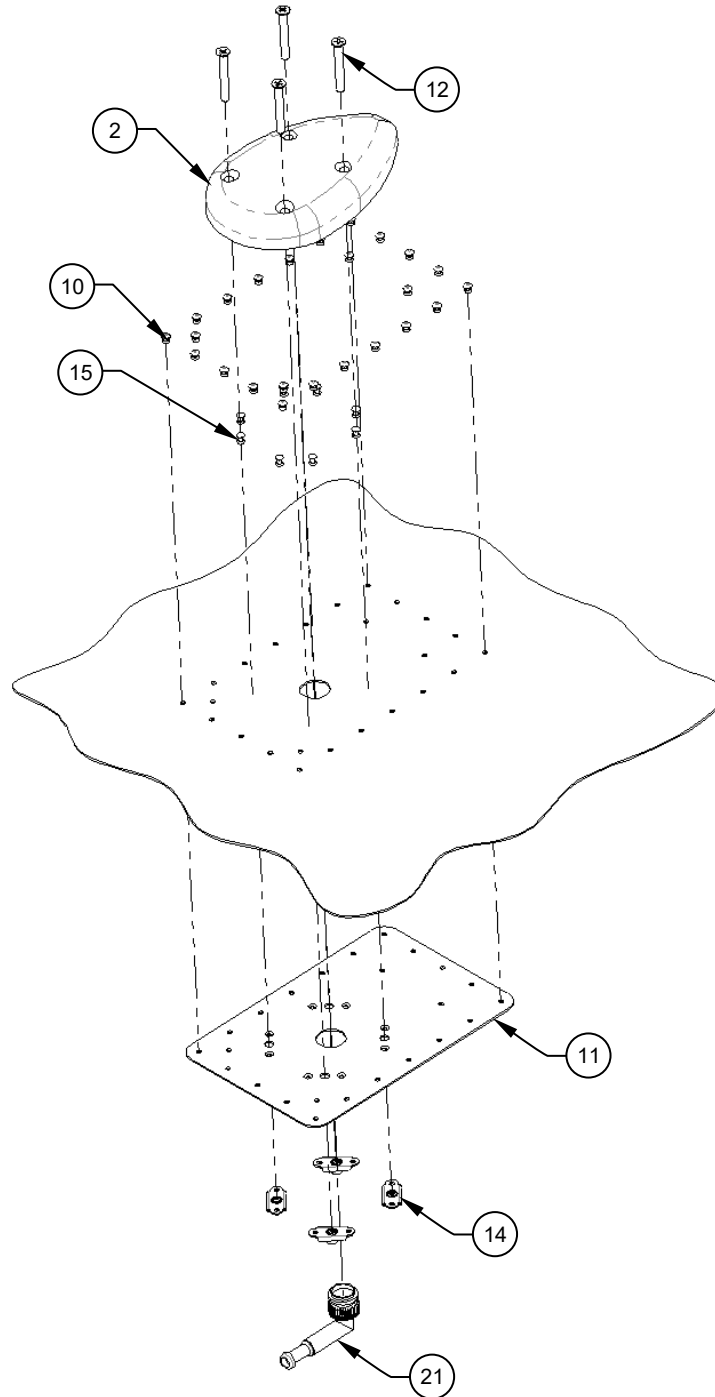

GPS Antenna
Installation Shown

Illustrated Parts Breakdown (cont.)

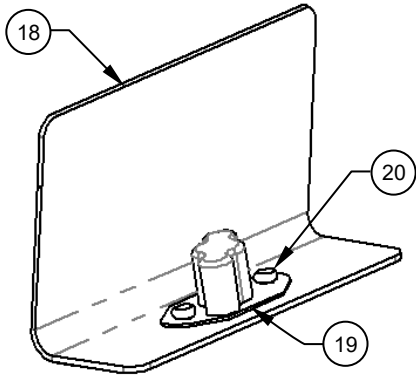

Clip, Assy (Item 17)
Shown

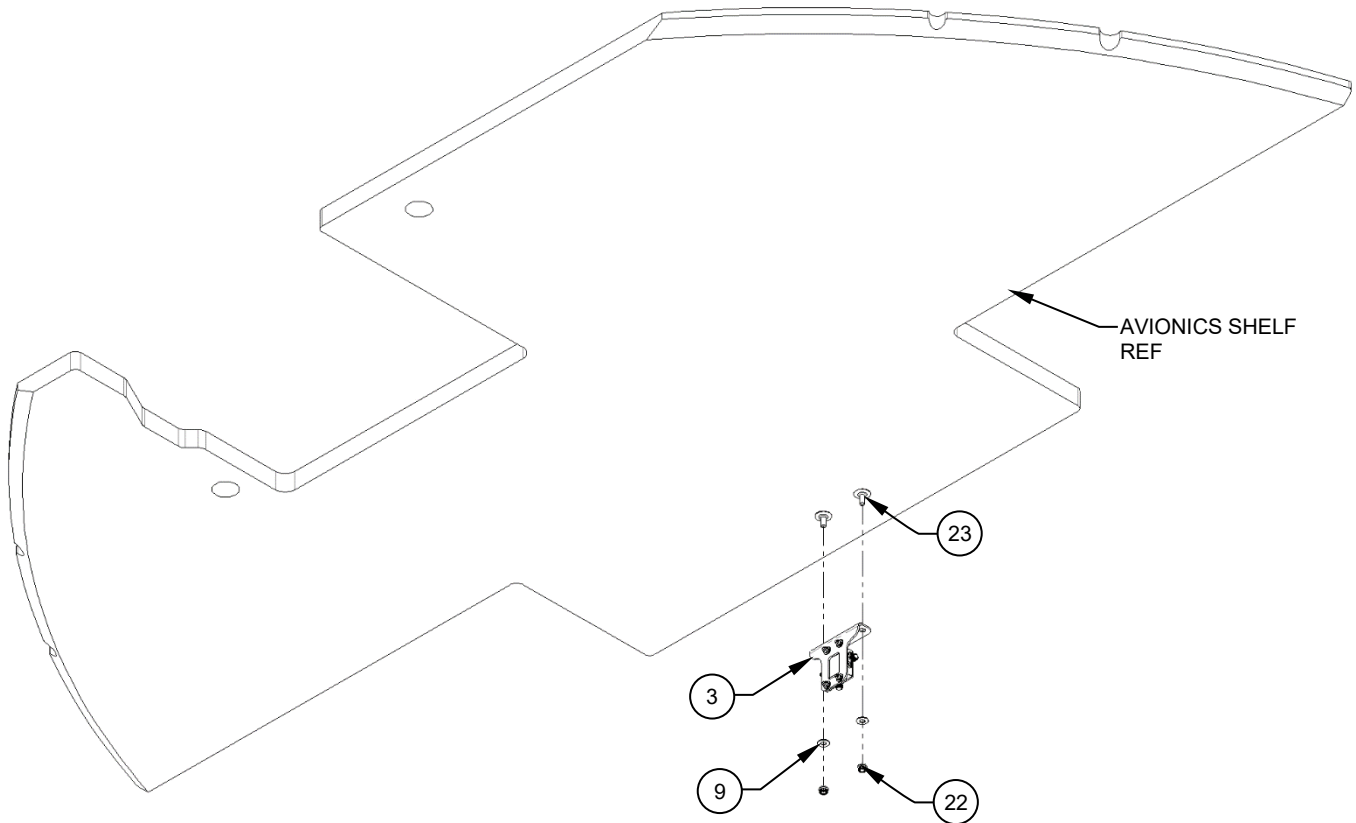
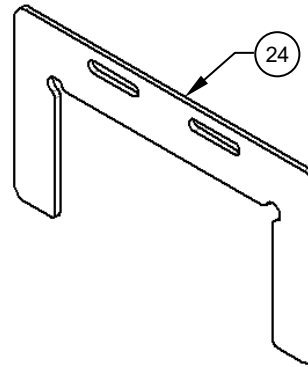

Splitter, Assy
Installation shown

Illustrated Parts Breakdown (cont.)

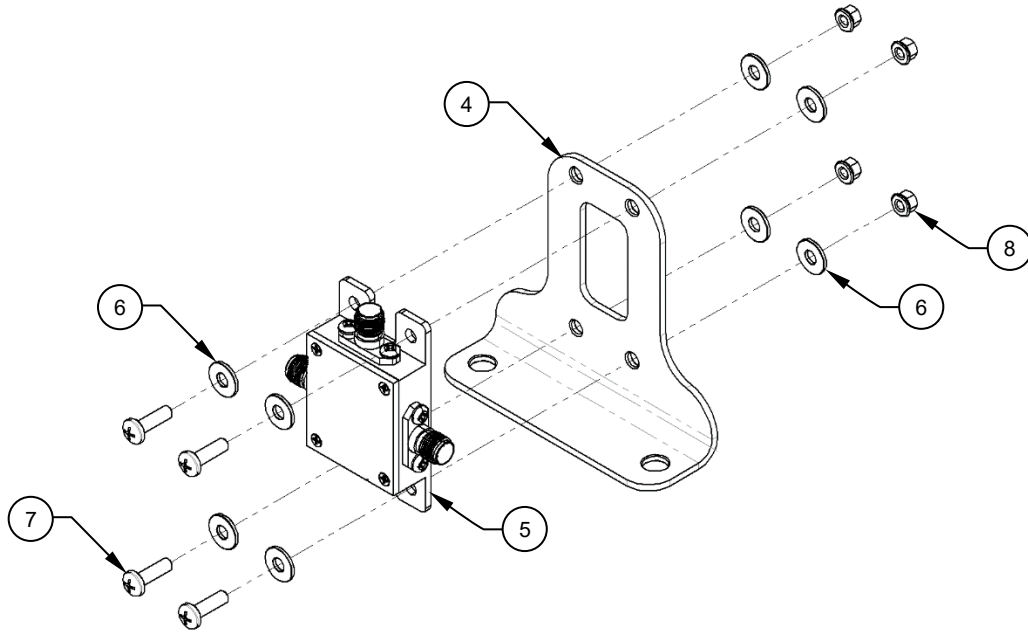

**Splitter, Assy (Item 3)
Shown**

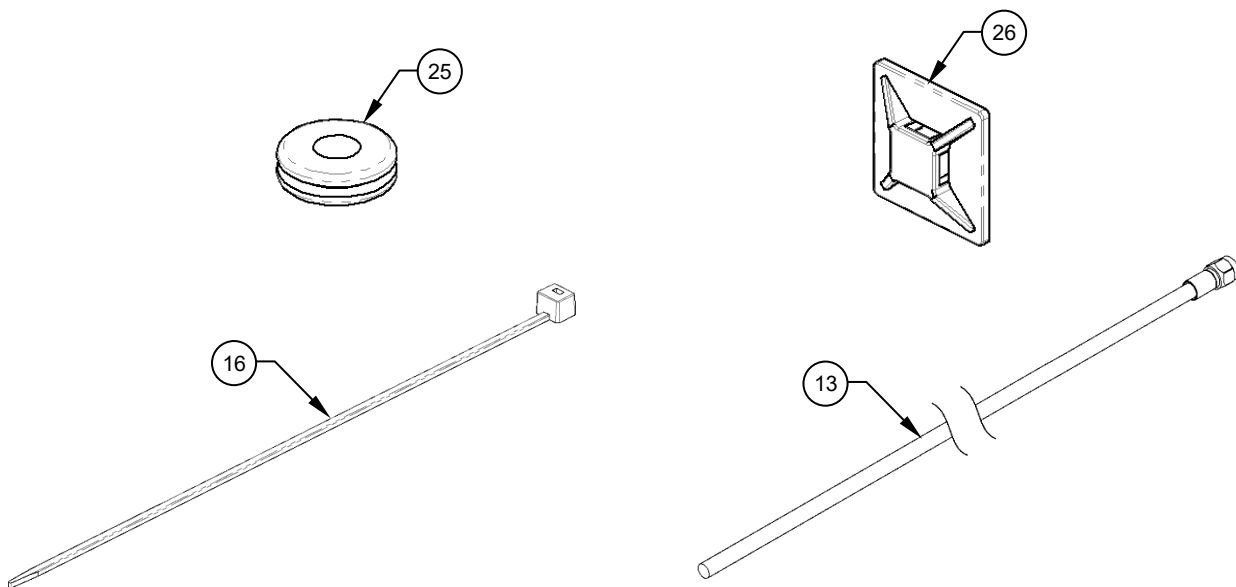

**Common Parts, Kit (Item 1)
Shown**

Illustrated Parts Breakdown (cont.)

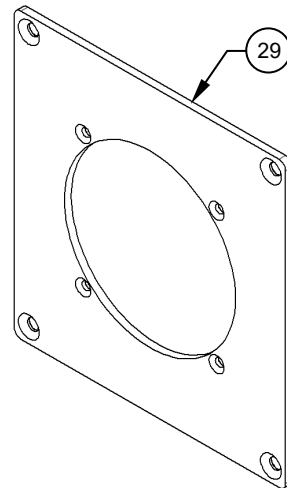
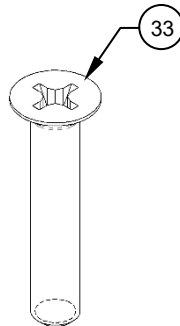
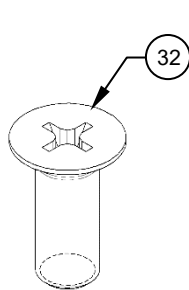
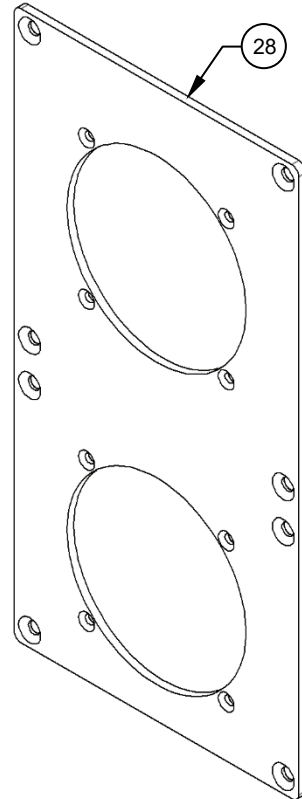
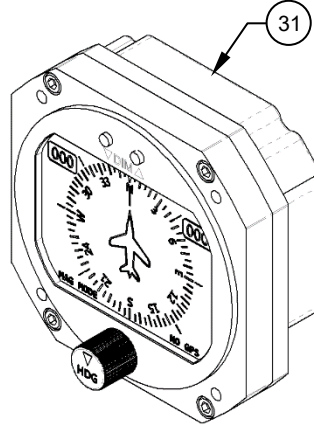
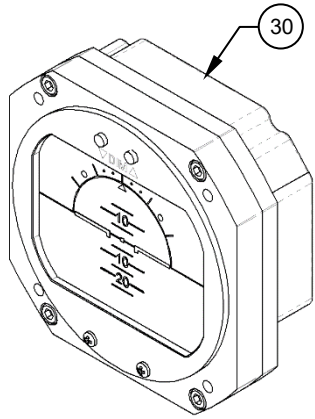

Instrument, Kit (Item 27)
Shown

Illustrated Parts Breakdown (cont.)

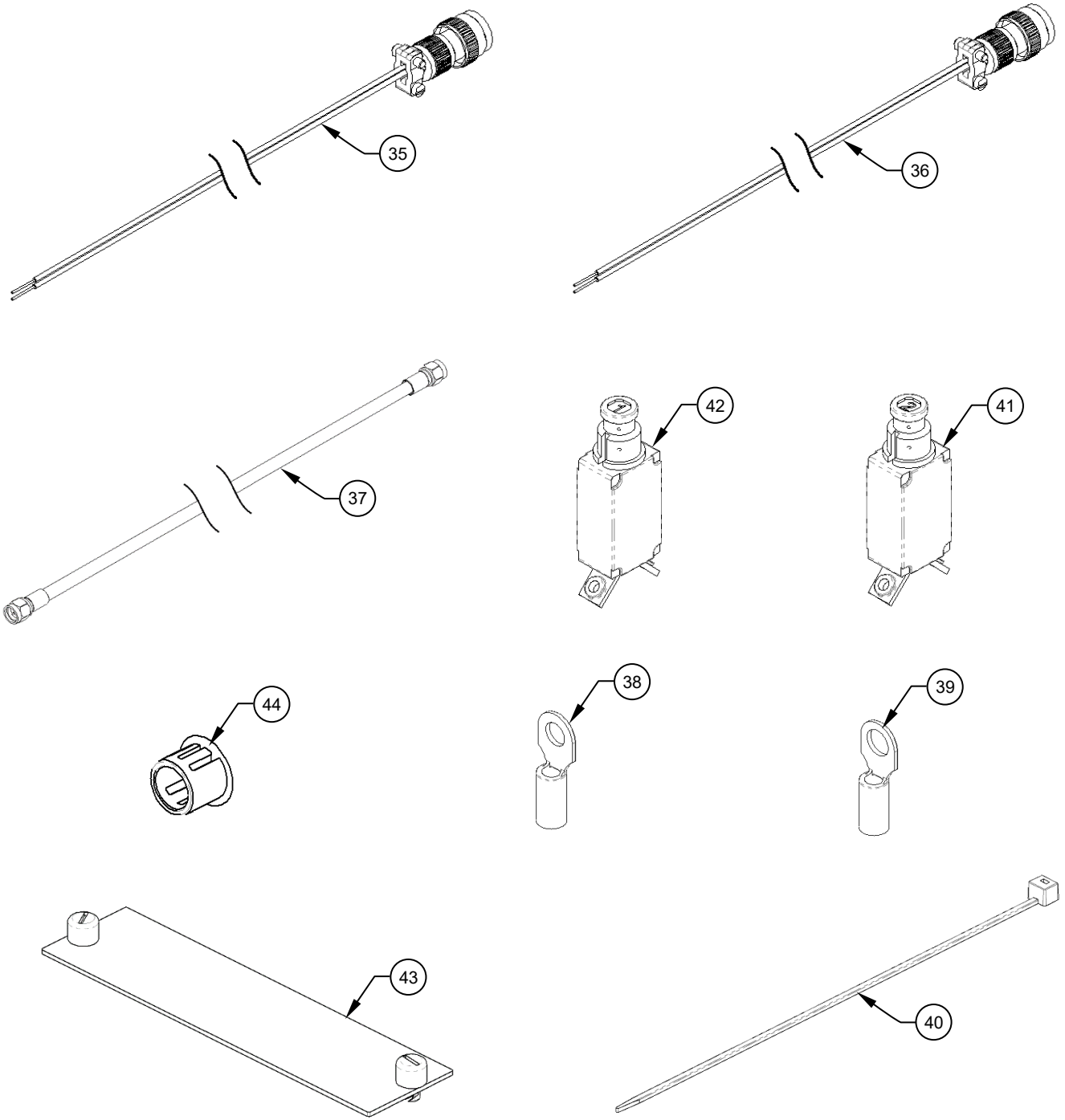

Wiring Harness, Kit, LHS (Item 34)
Shown

Illustrated Parts Breakdown (cont.)

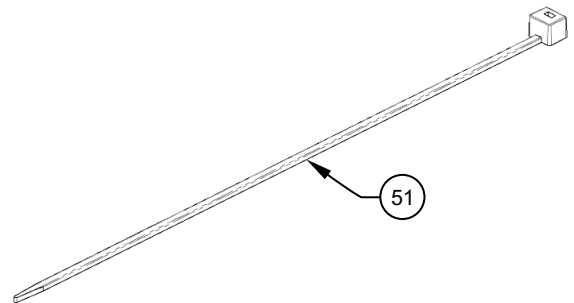
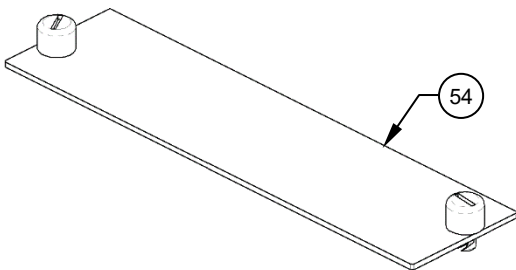
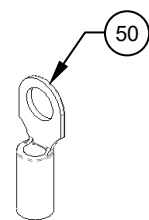
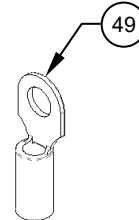
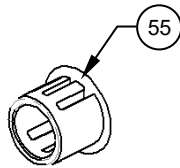
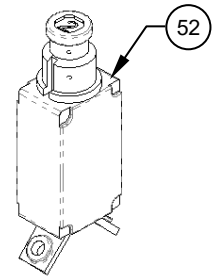
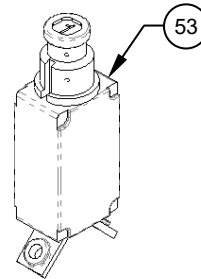
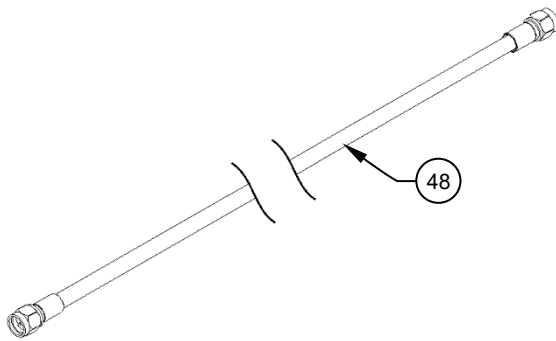
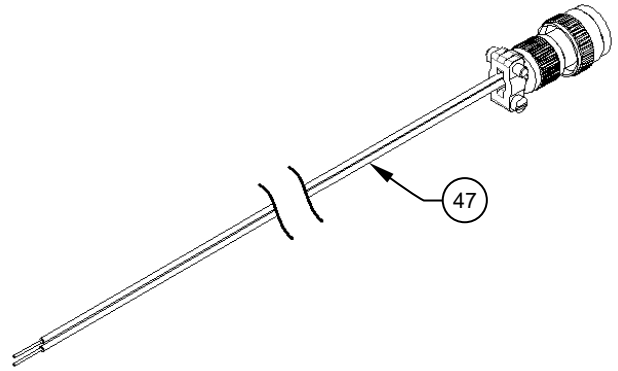
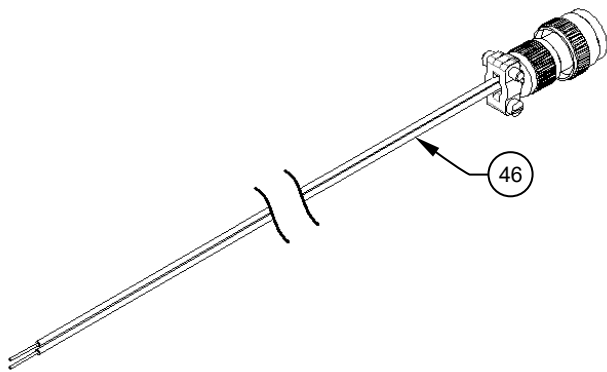

Wiring Harness, Kit, RHS (Item 45)
Shown

Illustrated Parts Breakdown (cont.)

ITEM	QTY	NUMBER	DESCRIPTION	MATERIAL	REF STOCK SIZE	SPEC	FINISH	MANUFACTURER	NCAGEC
-	-	AAL-280-040-901	BASIC DIGITAL FLIGHT INSTRUMENT, KIT	C/O SHADED ITEMS				ALPINE AEROTECH LP	L0171
2	-	AAL-280-040-902	BASIC DIGITAL FLIGHT INSTRUMENT, KIT, LHS	C/O SHADED ITEMS				ALPINE AEROTECH LP	L0171
3	-	AAL-280-040-903	BASIC DIGITAL FLIGHT INSTRUMENT, KIT, RHS	C/O SHADED ITEMS				ALPINE AEROTECH LP	L0171
1	1	AAL-280-040-001	COMMON PARTS, KIT	NA	NA	NA	NA	ALPINE AEROTECH LP	L0171
2	1	>013-00235-00	GA35 GPS ANTENNA	SEE MFR	SEE MFR	SEE MFR	SEE MFR	GARMIN	NA
3	1	>AAL-280-041-001	SPLITTER, ASSY	NA	NA	NA	NA	ALPINE AEROTECH LP	L0171
4	1	>>AAL-280-042-003	BRACKET, DETAIL	NA	NA	NA	NA	ALPINE AEROTECH LP	L0171
5	1	>>S12T-E-SF	SPLITTER, GPS	SEE MFR	SEE MFR	SEE MFR	SEE MFR	GPS SOURCE INC.	1RTJ5
6	8	>>NAS1149CN432R	WASHER, FLAT	SEE SPEC	SEE SPEC		SEE SPEC	SOURCE AS REQUIRED	NA
7	4	>>MS35206-215	SCREW, MACHINE, PAN-HEAD	SEE SPEC	SEE SPEC		SEE SPEC	SOURCE AS REQUIRED	NA
8	4	>>MS21043-04	NUT, SELF-LOCKING	SEE SPEC	SEE SPEC		SEE SPEC	SOURCE AS REQUIRED	NA
9	2	>NAS1149F0332P	WASHER, FLAT	SEE SPEC	SEE SPEC		SEE SPEC	BHT	97499
10	24	>MS20470AD3-3-5	RIVET, SOLID, UNIVERSAL HEAD	SEE SPEC	SEE SPEC		SEE SPEC	SOURCE AS REQUIRED	NA
11	1	>AAL-280-042-002	DOUBLER, DETAIL	NA	NA	NA	NA	ALPINE AEROTECH LP	L0171
12	4	>MS24693-C56	SCREW, MACHINE	SEE SPEC	SEE SPEC		SEE SPEC	SOURCE AS REQUIRED	
13	1	>AAL-280-041-002	COAX CABLE, ASSY	NA	NA	NA	NA	ALPINE AEROTECH LP	L0171
14	4	>MS21059L08	NUT PLATE, SELF-LOCKING	SEE SPEC	SEE SPEC		SEE SPEC	SOURCE AS REQUIRED	NA
15	8	>MS20426AD3-4	RIVET, SOLID, C-SUNK HEAD	SEE SPEC	SEE SPEC		SEE SPEC	SOURCE AS REQUIRED	NA
16	10	>MS3367-()-9	STRAP, TIE DOWN, ELECTRICAL	SEE SPEC	SEE SPEC	AS33671	SEE SPEC	SOURCE AS REQUIRED	NA
16	10	>PLT2M-M	STRAP, TIE DOWN, ELECTRICAL	SEE MFR	SEE MFR	SEE MFR	SEE MFR	PANDUIT CORP.	06383
17	1	>AAL-280-041-009	CLIP, ASSY	NA	NA	NA	NA	ALPINE AEROTECH LP	L0171
18	1	>>AAL-28-042-009	CLIP, DETAIL	NA	NA	NA	NA	ALPINE AEROTECH LP	L0171
19	1	>>50-008R2	RECEPTACLE	SEE SPEC	SEE SPEC	50-008	SEE SPEC	BHT	97499
20	2	>>MS20426AD3-3	RIVET, SOLID, C-SUNK HEAD	SEE SPEC	SEE SPEC		SEE SPEC	SOURCE AS REQUIRED	NA
21	1	>225554-6	TNC CONNECTOR, RHT ANGLE	SEE SPEC	SEE SPEC	MIL-STD-348	SEE SPEC	TE CONNECTIVITY	U0HF6
22	2	>NAS9926-3L	NUT, SELF LOCKING	SEE SPEC	SEE SPEC	NAS9926	SEE SPEC	SOURCE AS REQUIRED	NA
23	2	>CB5000CR3-8	STUD, SMALL BASE, ADHESIVE MOUNTED	SEE MFR	SEE MFR	SEE MFR	SEE MFR	CLICK BOND	66530
23	2	>CB5000CRA3-8	STUD, SMALL BASE, ADHESIVE MOUNTED	SEE MFR	SEE MFR	SEE MFR	SEE MFR	CLICK BOND	66530

Illustrated Parts Breakdown (cont.)

ITEM	QTY	NUMBER	DESCRIPTION	MATERIAL	REF STOCK SIZE	SPEC	FINISH	MANUFACTURER	NCAGEC
24	1	>AAL-280-042-011	TEMPLATE, DETAIL	NA	NA	NA	NA	ALPINE AEROTECH LP	L0171
25	2	>MS35489-6	GROMMET, RUBBER	SEE SPEC	SEE SPEC	MS35489	SEE SPEC	SOURCE AS REQUIRED	NA
26	4	>ABMM-A-C	CABLE TIE MOUNT	ABS	.75 X .75	SEE MFR	SEE MFR	PANDUIT CORP.	06383
27	2	AAL-280-040-002	INSTRUMENT, KIT	NA	NA	NA	NA	ALPINE AEROTECH LP	L0171
28	1	>AAL-280-042-001	ADAPTOR, DETAIL	NA	NA	NA	NA	ALPINE AEROTECH LP	L0171
29	1	>AAL-280-042-008	ADAPTOR, DETAIL	NA	NA	NA	NA	ALPINE AEROTECH LP	L0171
30	1	>102-0403-11-03	RCA2610-3-G ATTITUDE IND.	NA	NA	NA	NA	KELLY MFG CO	08AF1
31	1	>103-0503-03-01	RCA1510-3 HEADING IND.	NA	NA	NA	NA	KELLY MFG CO	08AF1
32	8	>MS24693-BB274	SCREW, MACHINE	SEE SPEC	SEE SPEC		SEE SPEC	SOURCE AS REQUIRED	NA
33	8	>MS24693-BB30	SCREW, MACHINE	SEE SPEC	SEE SPEC		SEE SPEC	SOURCE AS REQUIRED	NA
34	1	AAL-280-040-003	WIRING HARNESS, KIT, LHS	NA	NA	NA	NA	ALPINE AEROTECH LP	L0171
35	1	>AAL-280-041-005	WIRING HARNESS, ASSY	NA	NA	NA	NA	ALPINE AEROTECH LP	L0171
36	1	>AAL-280-041-006	WIRING HARNESS, ASSY	NA	NA	NA	NA	ALPINE AEROTECH LP	L0171
37	1	>AAL-280-041-003	COAX CABLE, ASSY	NA	NA	NA	NA	ALPINE AEROTECH LP	L0171
38	2	>MS25036-149	TERMINAL LUG, CRIMP STYLE	SEE SPEC	SEE SPEC	SAE-AS25036	SEE SPEC	SOURCE AS REQUIRED	NA
38	2	>31890	TERMINAL LUG, CRIMP STYLE	SEE MFR	SEE MFR	SEE MFR	SEE MFR	TE CONNECTIVITY	U0HF6
39	2	>MS25036-103	TERMINAL LUG, CRIMP STYLE	SEE SPEC	SEE SPEC	SAE-AS25036	SEE SPEC	SOURCE AS REQUIRED	NA
39	2	>36154	TERMINAL LUG, CRIMP STYLE	SEE MFR	SEE MFR	SEE MFR	SEE MFR	TE CONNECTIVITY	U0HF6
40	10	>MS33667-()-9	STRAP, TIE DOWN, ELECTRICAL	SEE SPEC	SEE SPEC	AS33671	SEE SPEC	SOURCE AS REQUIRED	NA
40	10	>PLT2M-M	STRAP, TIE DOWN, ELECTRICAL	SEE MFR	SEE MFR	SEE MFR	SEE MFR	PANDUIT CORP.	06383
41	1	>MS22073-2	CIRCUIT BREAKER, TRIP FREE, PUSH-PULL	SEE SPEC	SEE SPEC	AS22073	SEE SPEC	SOURCE AS REQUIRED	NA
41	1	>7274-11-2	CIRCUIT BREAKER, TRIP FREE, PUSH-PULL	SEE SPEC	SEE SPEC	AS22073	SEE SPEC	SENSATA TECH.	82647
42	1	>MS22073-1	CIRCUIT BREAKER, TRIP FREE, PUSH-PULL	SEE SPEC	SEE SPEC	AS22073	SEE SPEC	SOURCE AS REQUIRED	NA
42	1	>7274-11-1	CIRCUIT BREAKER, TRIP FREE, PUSH-PULL	SEE SPEC	SEE SPEC	AS22073	SEE SPEC	SENSATA TECH.	82647
43	1	>AAL-280-041-010	PLATE, ASSY	NA	NA	NA	NA	ALPINE AEROTECH LP	L0171
44	8	>245-049	CAP-PLUG, PLASTIC	SEE MFR	SEE MFR	SEE MFR	SEE MFR	SPAENAU	94223
45	1	AAL-280-040-004	WIRING HARNESS, KIT, RHS	NA	NA	NA	NA	ALPINE AEROTECH LP	L0171
46	1	>AAL-280-041-007	WIRING HARNESS, ASSY	NA	NA	NA	NA	ALPINE AEROTECH LP	L0171
47	1	>AAL-280-041-008	WIRING HARNESS, ASSY	NA	NA	NA	NA	ALPINE AEROTECH LP	L0171
48	1	>AAL-280-041-004	COAX CABLE, ASSY	NA	NA	NA	NA	ALPINE AEROTECH LP	L0171

Illustrated Parts Breakdown (cont.)

ITEM	QTY	NUMBER	DESCRIPTION	MATERIAL	REF STOCK SIZE	SPEC	FINISH	MANUFACTURER	NCAGEC
49	2	>MS25036-149	TERMINAL LUG, CRIMP STYLE	SEE SPEC	SEE SPEC	SAE-AS25036	SEE SPEC	SOURCE AS REQUIRED	NA
49	2	>31890	TERMINAL LUG, CRIMP STYLE	SEE MFR	SEE MFR	SEE MFR	SEE MFR	TE CONNECTIVITY	U0HF6
50	2	>MS25036-103	TERMINAL LUG, CRIMP STYLE	SEE SPEC	SEE SPEC	SAE-AS25036	SEE SPEC	SOURCE AS REQUIRED	NA
50	2	>36154	TERMINAL LUG, CRIMP STYLE	SEE MFR	SEE MFR	SEE MFR	SEE MFR	TE CONNECTIVITY	U0HF6
51	10	>MS33667-()-9	STRAP, TIE DOWN, ELECTRICAL	SEE SPEC	SEE SPEC	AS33671	SEE SPEC	SOURCE AS REQUIRED	NA
51	10	>PLT2M-M	STRAP, TIE DOWN, ELECTRICAL	SEE MFR	SEE MFR	SEE MFR	SEE MFR	PANDUIT CORP.	06383
52	1	>MS22073-2	CIRCUIT BREAKER, TRIP FREE, PUSH-PULL	SEE SPEC	SEE SPEC	AS22073	SEE SPEC	SOURCE AS REQUIRED	NA
52	1	>7274-11-2	CIRCUIT BREAKER, TRIP FREE, PUSH-PULL	SEE MFR	SEE MFR	AS22073	SEE SPEC	SENSATA TECH.	82647
53	1	>MS22073-1	CIRCUIT BREAKER, TRIP FREE, PUSH-PULL	SEE SPEC	SEE SPEC	AS22073	SEE SPEC	SOURCE AS REQUIRED	NA
53	1	>7274-11-1	CIRCUIT BREAKER, TRIP FREE, PUSH-PULL	SEE MFR	SEE MFR	AS22073	SEE SPEC	SENSATA TECH.	82647
54	1	>AAL-280-041-010	PLATE, ASSY	NA	NA	NA	NA	ALPINE AEROTECH LP	L0171
55	8	>245-049	CAP-PLUG, PLASTIC	SEE MFR	SEE MFR	SEE MFR	SEE MFR	SPAENAUER	94223
4	C01	AR N/A	SEALANT, CORROSION INHIBITIVE	PS 870, CLASS B	SEE MFR	MIL-PRF-81733	NA	PRC-DESOTO INTERNATIONAL	83574
4	C02	AR HYSOL EA 9309.3NA	HYSOL EPOXY PASTE ADHESIVE	EA 9309.3NA	NA	SEE MFR	NA	HENKEL LOCTITE	79436

APPENDIX: A Electrical Connections

Electrical Notes

This appendix outlines the electrical details associated with the installation of the Basic Digital Flight Instrument, Kit and includes the wiring schematic.

1. Unless otherwise specified, all wiring terminations at connectors shall be IAW BHT-ELECT-SPM Chapters 4, 5 and 7 and the connector manufacturer's instructions or applicable military or commercial standard for stripping procedures, crimping procedures and required tooling.
2. Use existing ground stud or ground block if available. If new ground studs or ground blocks are required, install IAW BHT-ELECT-SPM, Chapter 8.
3. All wiring shall be routed and secured IAW BHT-ELECT-SPM, Chapter 6. Particular attention to minimum bend radii, clamp spacing, service loop separation from control, and fluid and oxygen system must be observed.
4. Refer to ICA document AAL-280-045-701, Section 4: Illustrated Parts Breakdown for the part numbers of the item(s) referenced within this appendix.

 When installing one side only (pilot or co-pilot) always connect coax cable to the "OUT 1" port on the Splitter, GPS (Item 5).

1. Wiring Schematic

