

## **CABIN FLOOR BOARD, KIT, FWD; INSTRUCTIONS FOR CONTINUING AIRWORTHINESS**

**MODELS: 205A, 205A1, 205B, 212, 412, 412EP, 412CF**

Read all of the Instructions for Continuing Airworthiness thoroughly prior to performing any activities relating to this product

## **Table of Contents**

<u>Section</u>	<u>Description</u>	<u>Page</u>
1	Description	2
2	Maintenance Manual Supplement	3
3	Installation & Removal Instructions	7
	Installation Instructions	8
	Removal Instructions	12
4	Illustrated Parts Breakdown	13

## **Notes**

1. If changes to this document are required, Alpine Aerotech LP shall revise all pages and reissue the entire document.
2. Alpine Aerotech LP shall make any subsequent revisions of this document available free of charge upon request. Alpine Aerotech LP also recommends that the end user of this product periodically verify the revision level of this document.

## **Section 1: Description**

### **Description**

The following information provides a functional description of the Cabin Floor Board, Kit, FWD as defined in Alpine Aerotech LP authority dataset AAL-212-020-020.

- The Floor Protection, Kits are rigid pieces of material that are installed atop the existing floor to protect it from dents and punctures associated with typical aircraft usage. This occurs most frequently during loading and unloading operations, but can also occur during small inflight shifts of said cargo.
- The Cabin Floor Board, Kit, FWD when installed, adds additional protection to the floor panels, as it is manufactured from a material specifically designed to spread and attenuate energy.

## **Section 2: Maintenance Manual Supplement**

### **General Notes**

1. The following information defines the instructions for continuing airworthiness, repair allowances and airworthiness limitations for the item(s) referenced within this document.
2. Refer to the current revisions of the Bell 205A, 205A1, 205B, 212, 412, 412 EP & 412CF Maintenance Manual for Instructions for Maintenance/Inspection with respect to the item(s) referenced within this document.
3. Refer to the Section 3: Installation & Removal Instructions and Section 4: Illustrated Parts Breakdown for the replacement and/or installation of the item(s) referenced within this section.
4. Scheduled inspection for the item(s) referenced within this document shall be accomplished in accordance with (IAW) the Inspection Procedures specified.
5. Repair allowances for the item(s) referenced within this document shall be accomplished IAW the Repair Procedures specified.
6. Limitations for the item(s) referenced within this document are IAW the Airworthiness Limitations specified.

### **Airworthiness Limitations**

The Airworthiness Limitations section is approved by the Minister and specifies maintenance required by any applicable airworthiness or operating rule unless an alternative program has been approved by the Minister.

The Airworthiness Limitations section is FAA approved and specifies maintenance required under Sections 43.16 and 91.403 of the Federal Aviation Regulations unless an alternative program has been FAA approved.

### **Supplement to applicable Maintenance Manual, Chapter 4, Airworthiness Limitations Schedule**

#### **Notes**

1. Refer to the applicable Maintenance Manual, Chapters, for general information on airworthiness limitations and airworthiness limitation schedules.
2. Item(s) **not** listed in the Scheduled Airworthiness Limitations section within this document have an unlimited airworthiness life.

#### **Scheduled Airworthiness Limitations**

1. There are no airworthiness limitations associated with the item(s) referenced within this document.

## **Inspection Procedures**

### **Supplement to applicable Maintenance Manual, Chapter 5, Inspection and Component Overhaul Schedule**

#### **Notes**

1. Refer to the applicable Maintenance Manual, Chapter 4-1 and 4-2, for general information on inspections, inspection definitions, inspection intervals, inspection methods and inspection schedules.
2. General Inspections, as indicated within this document, are defined as visual, non-thorough checks.
3. Detailed Inspections, as indicated within this document, are defined as visual and thorough, searching checks.
4. Perform 200 Hour/12 Month Inspections every 200 hours or every 12 months, whichever occurs first, prior to flight operation. If damage is detected, refer to the Repair Procedures section within this document.

#### **Scheduled Inspections**

1. 200 Hour/12 Month Inspections  
  
Data Reference: Section 3: Installation and Removal Instructions  
Section 4: Illustrated Parts Breakdown
  - I. Perform a Detailed Inspection on all items to ensure proper security.
  - II. Perform a Detailed Inspection on all items/materials to ensure proper integrity.
  - III. Perform a Detailed Inspection on the Cabin Floor Protection, Kit FWD to ensure that it is not delaminating.
  - IV. Perform a Detailed Inspection on all surfaces & locations with Velcro applied to ensure no damage has occurred to the aircraft floor.

### **Repair Procedures**

1. Repairs to the item(s) referenced within this document are **not** permitted. Contact Alpine Aerotech LP for further information if repairs are required to the item(s) referenced within this document.

**Section 3: Installation & Removal Instructions**

**Weight & Balance**

<u>Part Number</u>	<u>Description</u>	<u>Weight</u>	<u>Long. Arm</u>	<u>Lat. Arm</u>
AAL-212-020-020	Cabin Floor Board, FWD, Kit	9.14lb*	92.0	0 RBL
		4.15 (Kg)	2.37 (m)	0 (m)

\* Total increase in weight to aircraft.

**General Notes**

1. All Installation Instructions shall be accomplished IAW standard aircraft practices. Refer to the current revision of the FAA publications AC 43.13-1B and AC 43.13-2B for details on standard aircraft practices.
2. All Dimensions are in imperial measures (inches/pounds).
3. Refer to Section 2: Maintenance Manual Supplement for instructions on maintenance for the item(s) referenced within this section.
4. Refer to the Section 4: Illustrated Parts Breakdown for the part numbers of the item(s) referenced within this section.

## **Installation Instructions**

1. Gain access to the cabin floor, temporarily remove forward facing passenger seats.
2. Apply Velcro to matching Velcro patch on the floor panel. Position the panel and apply adequate pressure to the Velcro to insure proper adhesion. See Figure 1.

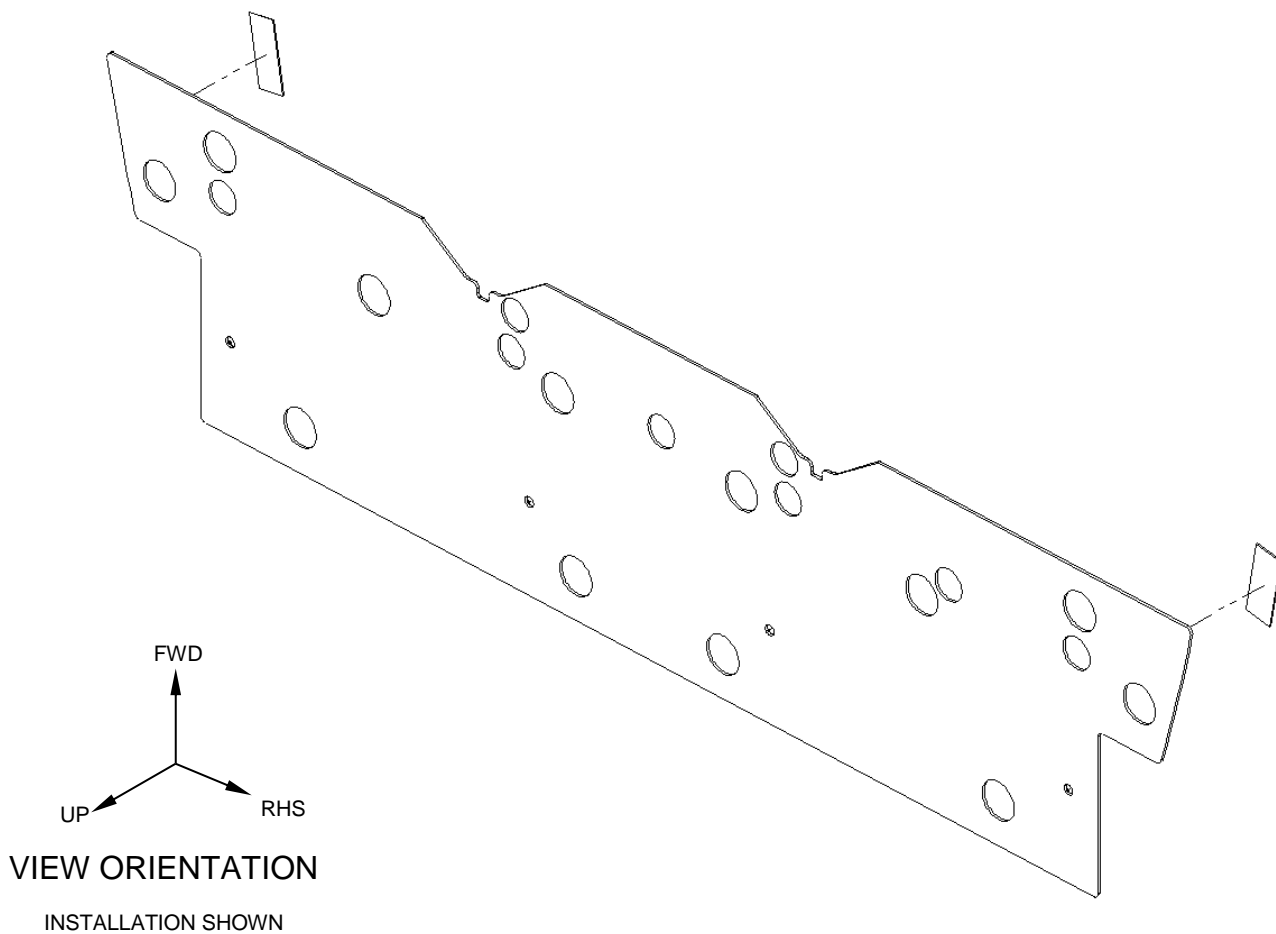

**Figure 1**  
Some Items  
Removed for  
Clarity



3. Remove and discard the original floor screws in 4 places as shown by Figure 2.
4. Place the 4 retainer caps (Item 2) into the corresponding holes. Screw the panel down using the x4 screws provided (Item 3). Reference Figures 2 and 3.

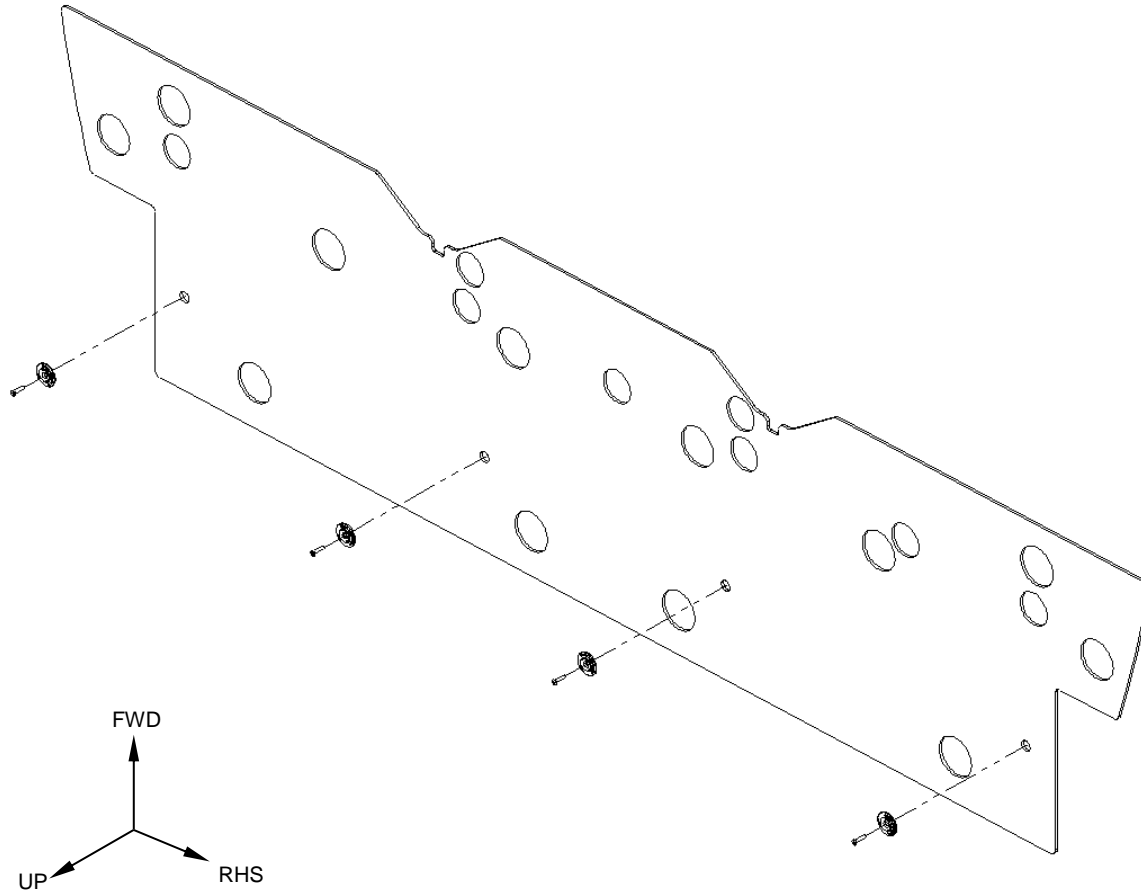

**VIEW ORIENTATION**  
INSTALLATION SHOWN

**Figure 2**  
Some Items  
Removed for  
Clarity

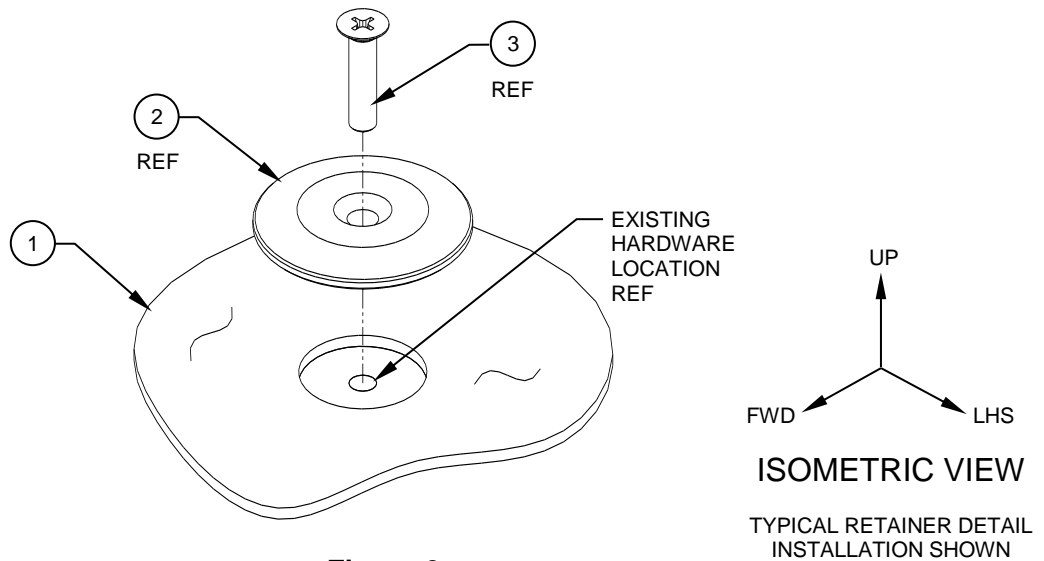

5. Reinstall passenger seats
6. Installation complete.
7. Perform a general inspection of all items to ensure proper installation.
8. Update the aircraft log book for the installation of the Cabin Floor Board, Kit, FWD.

## **Grip Tape Install**

1. Placement of the Grip Tape is optional. Its location is approximate and can be placed to suite the individual operators needs. See Figure 4.
2. Trimming may be required to clear the existing floor cutouts.

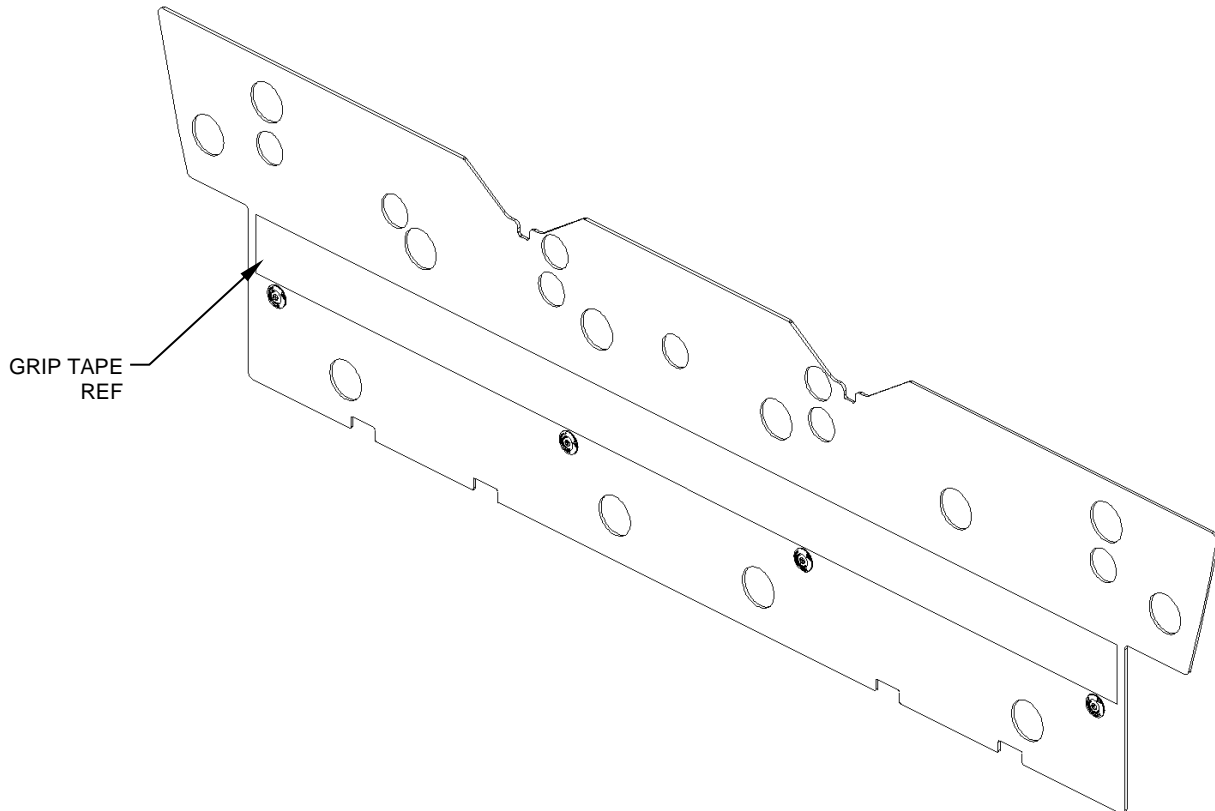

**Figure 4**

3. Ensure that adequate pressure is applied to promote a good bond between the grip tape and panel assy. **NOTE:** The tape will go from a milky to a more translucent appearance once it has bonded properly.

## **Removal Instructions**

1. For the removal the Cabin Floor Board, Kit, FWD for either inspections, or mission configuration, the removal of the CCG Floor Protection, Kit can be considered the opposite of installation for step 7 THRU 13. For permanent removal, of CCG Floor Protection, Kit remove all bonded Velcro, Details.
2. Perform a General Inspection of all items to ensure proper removal.
3. Update the aircraft logbook for the removal of the Cabin Floor Board, Kit, FWD.

**Section 4: Illustrated Parts Breakdown**

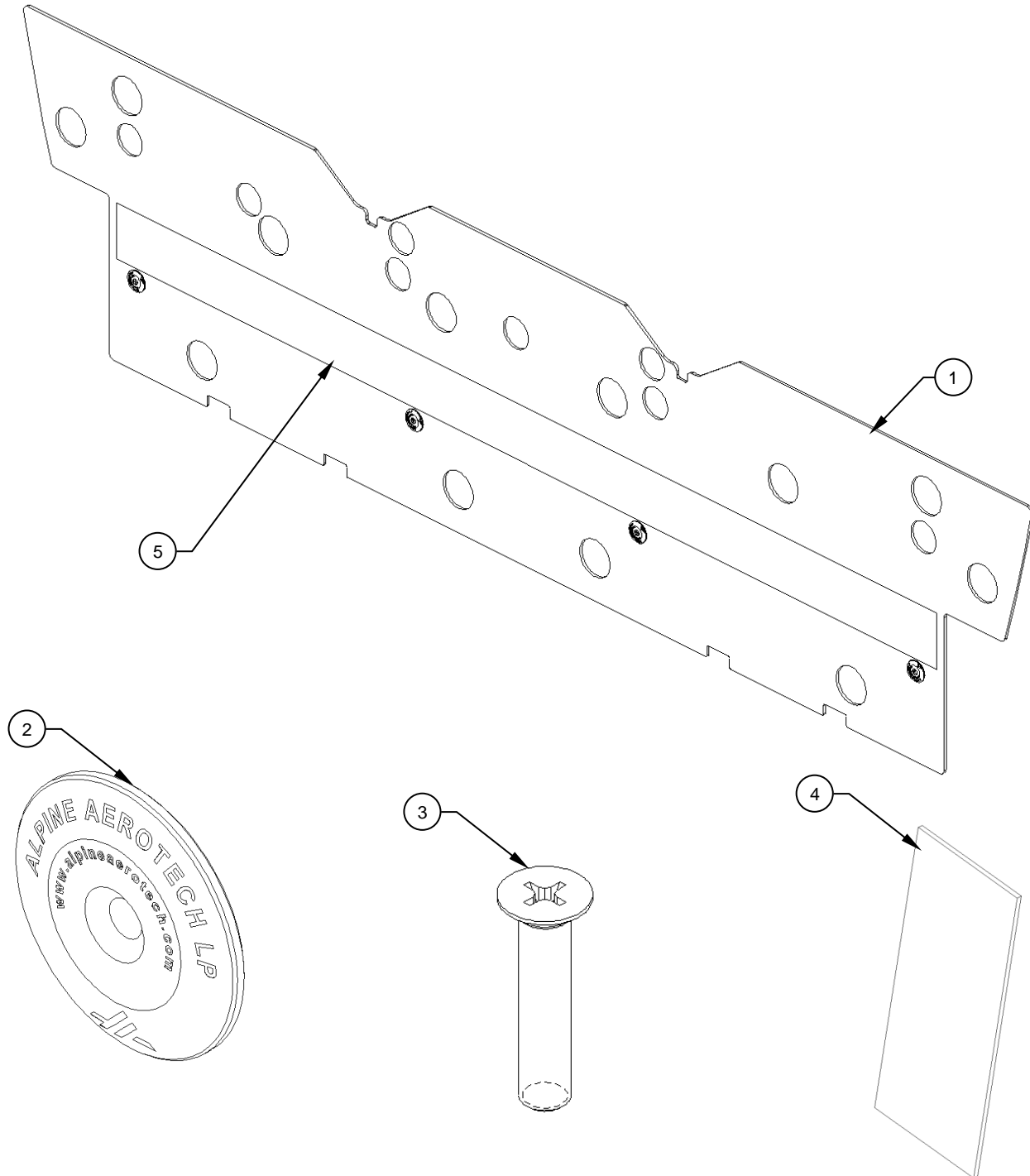

**Illustrated Parts Breakdown (Cont.)**

ITEM	QTY	NUMBER	DESCRIPTION	MATERIAL	REF STOCK SIZE	SPEC	FINISH	MANUFACTURER	NCAGEC
-	-	AAL-212-020-020	CABIN FLOOR BOARD, KIT, FWD	NA	NA	NA	NA	ALPINE AEROTECH LP	L0171
1	1	AAL-212-021-021	FORWARD CABIN PANEL, ASSY	NA	NA	NA	NA	ALPINE AEROTECH LP	L0171
2	4	AAL-212-022-010	RETAINER, DETAIL	ALUMINIUM 6061-T6	1.50	AMS 4117	SEE NOTES	ALPINE AEROTECH LP	L0171
3	4	MS24694-S56	MS24694 SCREW, MACHINE	SEE SPEC	SEE SPEC	NASM42694	SEE SPEC	SOURCE AS REQUIRED	NA
4	2	151405 Velcro	VELCRO, DETAIL	HOOK 88, BLACK, 8289 PSA	2.00 x 5.00	SEE MFG	SEE MFG	SOURCE AS REQUIRED	NA
5	1	NA	SAFETY-WALK GENERAL PURPOSE GRIP TAPE	NA	72.00"	NA	NA	SOURCE AS REQUIRED	NA